

**FM 8-51**

**COMBAT STRESS CONTROL  
IN A  
THEATER OF OPERATIONS**

---

**TACTICS, TECHNIQUES, AND PROCEDURES**

**HEADQUARTERS, DEPARTMENT OF THE ARMY**

**DISTRIBUTION RESTRICTION:** Approved for public release; distribution is unlimited.

CHANGE  
NO. 1

HEADQUARTERS  
DEPARTMENT OF THE ARMY  
Washington, DC, 30 January 1998

## COMBAT STRESS CONTROL IN A THEATER OF OPERATIONS TACTICS, TECHNIQUES, AND PROCEDURES

1. The combat stress control units were reorganized under the Medical Reengineering Initiative and these changes were incorporated into the A-Series Tables of Organization and Equipment. Combat stress control units will convert from the L-Series to the A-Series in the near future based on Department of the Army timelines.
2. Change FM 8-51, 29 September 1994, as follows:

### Remove old pages

v and vi  
2-1 and 2-2

Glossary-3 through Glossary-10  
References-1 and References-2

### Insert new pages

v and vi  
2-1 and 2-2

E-1 through E-39  
Glossary-3 through Glossary-10  
References-1 and References-2

3. New or changed material is indicated by a star (★).
4. File this transmittal sheet in front of the publication.

**DISTRIBUTION RESTRICTION:** Approved for public release; distribution is unlimited.

By Order of the Secretary of the Army:

Official:



JOEL B. HUDSON

Administrative Assistant to the  
Secretary of the Army

04305

DENNIS J. REIMER  
General, United States Army  
Chief of Staff

### DISTRIBUTION:

Active Army, Army National Guard, and U.S. Army Reserve: To be distributed in accordance with the initial distribution number 114901, requirements for FM 8-51.

# COMBAT STRESS CONTROL IN A THEATER OF OPERATIONS TACTICS, TECHNIQUES, AND PROCEDURES

## TABLE OF CONTENTS

		Page
PREFACE .....		vi
<b>CHAPTER</b>	<b>1. CONTROL OF COMBAT STRESS .....</b>	1-1
	1-1. Stress Control .....	1-1
	1-2. Combat Stress Threat .....	1-1
	1-3. Stress Behaviors in Combat .....	1-4
	1-4. Stressors and Stress in Army Operations .....	1-7
	1-5. Army Combat Stress Control .....	1-9
	1-6. Historical Experience .....	1-9
	1-7. Principles of Combat Psychiatry .....	1-11
	1-8. Generic Treatment Principles for Battle Fatigue .....	1-13
	1-9. Combat Stress Control Functional Mission Areas .....	1-15
<b>CHAPTER</b>	<b>2. MENTAL HEALTH AND COMBAT STRESS CONTROL ELEMENTS IN THE THEATER OF OPERATIONS .....</b>	2-1
<b>Section</b>	<b>I. Unit Mental Health Sections in the Theater .....</b>	2-1
	2-1. Locations and Assignments of Unit Mental Health Sections .....	2-1
	2-2. Division Mental Health Section .....	2-1
	2-3. Area Support Medical Battalion Mental Health Section .....	2-6
	2-4. Mental Health Personnel in the Separate Brigades .....	2-9
<b>Section</b>	<b>II. Combat Stress Control Company .....</b>	2-10
	2-5. Medical Company, Combat Stress Control (TOE 08-467L000) .....	2-10
	2-6. Headquarters Section .....	2-12
	2-7. Preventive Section .....	2-15
	2-8. Restoration Section .....	2-18
<b>Section</b>	<b>III. Combat Stress Control Detachment .....</b>	2-23
	2-9. Medical Detachment, Combat Stress Control (TOE 08-567LA00) .....	2-23
	2-10. Detachment Headquarters .....	2-25

**DISTRIBUTION RESTRICTION:** Approved for public release; distribution is unlimited.

		Page
	2-11.	Preventive Section ..... 2-25
	2-12.	Restoration Team ..... 2-27
<b>CHAPTER</b>	<b>3.</b>	<b>COMBAT STRESS CONTROL OPERATIONS IN THE COMBAT ZONE</b> ..... 3-1
<b>Section</b>	<b>I.</b>	<b>Division Mental Health/Combat Stress Control Operations</b> ..... 3-1
	3-1.	Division Mental Health Section Deployment ..... 3-1
	3-2.	Division Combat Stress Control Estimate and Plan ..... 3-1
	3-3.	Division Mental Health Section Employment ..... 3-3
	3-4.	Reinforcement of Brigade Combat Stress Control Team Using Division Mental Health Section Assets Only ..... 3-9
	3-5.	Corps-Level Mental Health/Combat Stress Control Support Reinforcement ..... 3-10
<b>Section</b>	<b>II.</b>	<b>Area Support Medical Battalion Mental Health/Combat Stress Control Support Operations</b> ..... 3-11
	3-6.	Mental Health Section Employment ..... 3-11
	3-7.	Disposition of Battle Fatigue and Neuropsychiatric Cases from the Area Support Medical Battalion ..... 3-13
<b>Section</b>	<b>III.</b>	<b>Support Operations Conducted by the Medical Detachment, Combat Stress Control</b> ..... 3-13
	3-8.	Medical Detachment, Combat Stress Control Employment ..... 3-13
	3-9.	Medical Detachment, Combat Stress Control Interface and Coordination Requirements ..... 3-16
<b>Section</b>	<b>IV.</b>	<b>Support Operations Conducted by the Medical Company, Combat Stress Control</b> ..... 3-18
	3-10.	Medical Company, Combat Stress Control Employment ..... 3-18
	3-11.	Medical Company, Combat Stress Control Coordination and Interface Requirements ..... 3-22
<b>CHAPTER</b>	<b>4.</b>	<b>COMBAT STRESS CONTROL CONSULTATION</b> ..... 4-1
	4-1.	Priorities and General Principles ..... 4-1
	4-2.	Consultant Activities During Predeployment and During Buildup and Waiting Phases in the Theater of Operations ..... 4-4
	4-3.	Combat Stress Control Consultant Activities for Staff and Operational Planning ..... 4-8
	4-4.	Consultation During Mobilization and Deployment ..... 4-9
	4-5.	Consultation Support During Combat ..... 4-10

		<b>Page</b>
	4-6. Consultation to Medical Treatment Facilities .....	4-14
	4-7. Consultation During Demobilization and Homecoming .....	4-17
<b>CHAPTER</b>	<b>5. COMBAT STRESS CONTROL FOR RECONSTITUTION SUPPORT .....</b>	<b>5-1</b>
	5-1. Reconstitution Support .....	5-1
	5-2. Phase I: Preparation and Deployment .....	5-4
	5-3. Phase II: Reduction of Human Physical/Physiologic and Cognitive Stressors .....	5-5
	5-4. Phase III: After-Action Debriefing .....	5-6
	5-5. Phase IV: Rebuilding Unit Cohesion .....	5-9
	5-6. Phase V: Performing Final Combat Stress Control Requirements for Reconstitution Support .....	5-10
<b>CHAPTER</b>	<b>6. COMBAT NEUROPSYCHIATRIC TRIAGE .....</b>	<b>6-1</b>
	6-1. Triage .....	6-1
	6-2. Considerations .....	6-4
	6-3. Differential Diagnostic Problems .....	6-5
<b>CHAPTER</b>	<b>7. COMBAT STRESS CONTROL STABILIZATION .....</b>	<b>7-1</b>
	7-1. Priority for Stabilization .....	7-1
	7-2. Use of Restraints in Initial (Emergency) Stabilization .....	7-1
	7-3. Use of Medication in Initial (Emergency) Stabilization .....	7-2
	7-4. Full Stabilization in Combat Stress Control .....	7-3
	7-5. Stabilization Treatment Facilities .....	7-4
<b>CHAPTER</b>	<b>8. COMBAT STRESS CONTROL RESTORATION .....</b>	<b>8-1</b>
	8-1. Restoration of Battle Fatigue Casualties .....	8-1
	8-2. Generic Tactics, Techniques, and Procedures of Restoration .....	8-1
	8-3. First-Line Restoration .....	8-8
	8-4. Second-Line Restoration (Fatigue Center) .....	8-10
	8-5. Third-Line Restoration .....	8-11
	8-6. Return to Duty or Further Referral of Restoration Cases .....	8-12
<b>CHAPTER</b>	<b>9. COMBAT STRESS CONTROL RECONDITIONING .....</b>	<b>9-1</b>
	9-1. Reconditioning Treatment Program .....	9-1
	9-2. Reconditioning Program Methods .....	9-1
	9-3. First-Line Reconditioning Centers .....	9-3

		<b>Page</b>	
	9-4.	Disposition of First-Line Reconditioning Cases.....	9-5
	9-5.	Second-Line Reconditioning in the Communications Zone.....	9-7
	9-6.	Third-Line Reconditioning.....	9-8
<b>APPENDIX</b>	<b>A.</b>	<b>LISTING OF MAJOR ITEMS OF EQUIPMENT FOR THEATER ARMY MEDICAL COMBAT STRESS CONTROL UNITS AND ELEMENTS .....</b>	<b>A-1</b>
	A-1.	General.....	A-1
	A-2.	Medical Company, Combat Stress Control.....	A-1
	A-3.	Medical Detachment, Combat Stress Control.....	A-3
	A-4.	Division Mental Health Section.....	A-4
	A-5.	Area Support Medical Battalion Mental Health Section.....	A-4
<b>APPENDIX</b>	<b>B.</b>	<b>COMBAT STRESS CONTROL ESTIMATES AND PLAN .....</b>	<b>B-1</b>
<b>Section</b>	<b>I.</b>	<b>Guide for the Development of the Combat Stress Control Estimate of the Situation .....</b>	<b>B-1</b>
	B-1.	Combat Stress Control Estimate .....	B-1
	B-2.	Estimating Battle Fatigue Casualty Work Load .....	B-2
	B-3.	Estimating Substance Abuse and Misconduct Stress Behaviors .....	B-5
<b>Section</b>	<b>II.</b>	<b>The Combat Stress Control Plan .....</b>	<b>B-7</b>
	B-4.	Format.....	B-7
	B-5.	Combat Stress Control Planning Considerations in Deployment and Conflict.....	B-7
	B-6.	Combat Stress Control Planning Considerations for War .....	B-8
	B-7.	Combat Stress Control Planning Considerations in Operations Other Than War .....	B-10
	B-8.	Considerations When Units or Individual Soldiers Redeploy Home (After Military Operations).....	B-11
	B-9.	Combat Stress Control Planning Considerations in Peacetime .....	B-11
	B-10.	Briefing the Combat Stress Control Plan .....	B-12
<b>APPENDIX</b>	<b>C.</b>	<b>MENTAL HEALTH PERSONNEL IN MILITARY POLICE CONFINEMENT FACILITY TEAMS.....</b>	<b>C-1</b>
	C-1.	Confinement Facility Teams .....	C-1
	C-2.	Teams LA, LB, LC, and LD .....	C-1
	C-3.	Mental Health Personnel.....	C-1

		<b>Page</b>
<b>APPENDIX</b>	<b>D. THE GENEVA CONVENTIONS AND COMBAT STRESS-RELATED CASUALTIES</b> .....	D-1
	D-1. Special Relevance to Medical Combat Stress Control .....	D-1
	D-2. Special Considerations for Medical Combat Stress Control Activities .....	D-1
	D-3. The Law of War .....	D-5
	D-4. Protection of the Wounded and Sick .....	D-6
	D-5. Protection and Identification of Medical Personnel .....	D-9
	D-6. Protection and Identification of Medical Units and Establishments, Buildings and Material, and Medical Transports .....	D-10
	D-7. Loss of Protection of Medical Units and Establishments .....	D-12
	D-8. Conditions Not Compromising Medical Units and Establishments of Protection .....	D-13
<b>★ APPENDIX</b>	<b>E. MEDICAL REENGINEERING INITIATIVE FOR MENTAL HEALTH AND COMBAT STRESS CONTROL ELEMENTS IN THE THEATER OF OPERATIONS</b> .....	E-1
<b>Section</b>	<b>I. Overview of Changes</b> .....	E-1
	E-1. Unit Mental Health Sections .....	E-1
	E-2. Combat Stress Control Units .....	E-2
<b>Section</b>	<b>II. Unit Mental Health Sections in the Theater of Operations</b> .....	E-5
	E-3. Location and Assignment of Unit Mental Health Sections .....	E-5
	E-4. Utilization in Garrison .....	E-5
	E-5. Division Mental Health Sections .....	E-6
	E-6. Area Support Medical Battalion Mental Health Sections .....	E-11
	E-7. Mental Health Personnel in the Armored Cavalry Regiments and Separate Brigades .....	E-15
<b>Section</b>	<b>III. Combat Stress Control Company</b> .....	E-15
	E-8. Medical Company, Combat Stress Control (TOE 08467A000) .....	E-15
	E-9. Headquarters Section .....	E-17
	E-10. Combat Stress Control Preventive Section .....	E-22
	E-11. Combat Stress Control Fitness Section .....	E-25
<b>Section</b>	<b>IV. Combat Stress Control Detachment</b> .....	E-30
	E-12. Medical Detachment, Combat Stress Control (TOE 08567AA00) .....	E-30
	E-13. Detachment Headquarters .....	E-31
	E-14. Preventive Section .....	E-34
	E-15. Combat Stress Control Fitness Section .....	E-36

	<b>Page</b>
<b>GLOSSARY</b> .....	Glossary-1
<b>REFERENCES</b> .....	References-1
<b>INDEX</b> .....	Index-1

## PREFACE

This field manual (FM) establishes medical doctrine and provides principles for conducting combat stress control (CSC) support operations from forward areas to the continental United States- (CONUS) based medical facilities. This manual sets forth tactics, techniques, and procedures (TTP) for CSC units and elements operating within the theater of operations (TO). This TTP is applicable to operations across the operational continuum. It is important that the users of this manual be familiar with FM 22-51. This manual supports the Army Medical Department's (AMEDD) keystone manual, FM 8-10. Readers should have a fundamental understanding of FMs 8-10-3, 8-10-5, 8-10-6, 8-10-8, 8-10-14, 8-10-24, 8-42, 8-55, 63-20, 63-21, 100-5, and 100-10.

The staffing and organizational structure presented in this publication reflects information in the most current living tables of organization and equipment (TOE) as of calendar year 1993. However, staffing is subject to change to comply with manpower requirements criteria outlined in AR 570-2. Your TOE can be subsequently modified.

★The Medical Reengineering Initiative (MRI) update has been added to this publication as Change 1, Appendix E. Organizational changes to CSC elements as a result of MRI were incorporated into the A-series TOE. CSC elements will convert from the L-series to the A-series TOE in the near future based on Department of the Army (DA) timelines.

This publication is in agreement with the American, British, Canadian, and Australian (ABCA) Quadripartite Standardization Agreement (QSTAG) 909, Principles of Prevention and Management of Combat Stress Reaction, Edition 1.

★The proponent of this publication is the United States (US) Army Medical Department Center and School (AMEDDC&S). Send comments and recommendations on DA Form 2028 directly to Commander, AMEDDC&S, ATTN: MCCA-FCD-L, 1400 East Grayson, Fort Sam Houston, Texas 78234-6175.

Unless this publication states otherwise, masculine nouns and pronouns do not refer exclusively to men.

Use of trade or brand names or trademarks in this publication is for illustrative purpose only, and does not imply endorsement by the Department of Defense (DOD).



## CHAPTER 1

## CONTROL OF COMBAT STRESS

## 1-1. Stress Control

a. *Control of Stress.* In one's own soldiers and in the soldiers of the enemy, control of stress is often the decisive difference between victory and defeat across the operational continuum. Battles and wars are won more by controlling the will to fight than by killing all of the enemy. Soldiers that are properly focused by training, unit cohesion, and leadership are most likely to have the strength, endurance, and alertness to perform their combat mission. In these soldiers, combat stress is controlled and positive combat stress reactions, such as loyalty, selflessness, and acts of bravery, are more likely to occur. However, uncontrolled combat stress causes erratic or harmful behavior, impairs mission performance, and results in disaster and defeat.

b. *Responsibility For Stress Control.* Control of stress is the commander's responsibility (see FM 22-51) at all echelons. The commander is aided in this responsibility by the noncommissioned officer (NCO) chain of support; the chaplaincy; unit medical personnel; general, principal, and special staff, and by specialized Army CSC units and mental health personnel.

c. *Control or Management.* The word *control* is used with combat stress (rather than the word *management*) to emphasize the active steps which leaders, supporting medical personnel, and individual soldiers must take to keep stress within an acceptable range. This does not mean that control and management are mutually exclusive terms. Management is by definition the exercise of control. Within common usage, however, and especially within Army usage, management has the connotation of being a somewhat detached, number-driven, higher echelon process rather than a direct, inspirational, and leadership-oriented process. Control of stress does not imply elimination of stress.

Stress is one of the body's processes for dealing with uncertain changes and danger. Elimination of stress is both impossible and undesirable in the Army's peacetime or combat mission.

## 1-2. Combat Stress Threat

a. *Stressors in Combat.* Many stressors in a combat situation are due to deliberate enemy actions aimed at killing, wounding, or demoralizing our soldiers and our allies. Other stressors are due to the natural environment. Some of these stressors can be avoided or counteracted by wise command actions. Still other stressors are due to our own calculated or miscalculated choice, accepted in order to exert greater stress on the enemy. Sound leadership works to keep these within tolerable limits and prepares the troops mentally and physically to endure them. Some of the most potent stressors can be due to personal or organizational problems in the unit or on the home front. These, too, must be identified and, when possible, corrected or controlled. See FMs 8-10, 8-10-8, and 22-51 for additional information on the overall threat, medical threat, and combat stress threat.

b. *Stress Casualties.* The combat stress threat includes all those stressors (risk factors) which can cause soldiers to become stress casualties. Stress casualties include—

- Battle fatigue (BF) cases which are held for treatment at medical treatment facilities (MTFs) for more than a day.
- Misconduct stress behaviors cases that have committed breaches of discipline which require disciplinary confinement.
- Post-traumatic stress disorder (PTSD) cases which disable the soldier for months or years after the battle.

The combat stress threat also includes some wounded in action (WIA) or disease and nonbattle injury (DNBI) casualties whose—

- Disabilities are a direct consequence of carelessness or inefficiency due to stress.
- Recovery and return to duty (RTD) is complicated by unresolved stress issues.

In a broader sense, the combat stress threat also includes the missed opportunities and increased casualties (killed, wounded, and/or taken prisoner) that come from impaired decision making or faulty execution of mission due to excessive stress.

*c. Mental Stressors and Physical Stressors.* A rough distinction can be made between those stressors which are “mental” and those which are “physical.”

(1) A mental stressor would be one in which information is sent to the brain, with only indirect physical impact on the body. This information may place demands on and evoke reactions from either the perceptual and cognitive system, or the emotional systems in the brain, or from both.

(2) A physical stressor is one which has a direct, potentially harmful effect on the body. These stressors may be external environmental conditions or the internal physical/physiologic demands required by or placed upon the human body.

(3) Table 1-1, *Combat Stressors*, gives examples for the two types of mental stressors (cognitive and emotional) and the two types for physical stressors (environmental and physiological).

(4) The physical stressors evoke specific “stress reflexes,” such as shivering and vasoconstriction (for cold), sweating and vasodilation (for heat), or tension of the eardrum (for noise), and so forth. A soldier’s stress reflexes can counteract the damaging impact of the stressors up to a point but may be overwhelmed.

(5) The distinction between mental and physical stressors is rarely obvious.

(a) Mental stressors can also produce some of the same stress reflexes nonspecifically (such as vasoconstriction, sweating, adrenaline release). These stress reflexes can markedly increase or decrease an individual’s vulnerability to specific physical stressors. Mental stressors presumably cause changes in the electrochemical (neurotransmitter) systems in the brain.

(b) Physical stressors can result in mental stress because they cause discomfort, impair performance, and provide information which poses a threat.

(c) Physical stressors can interfere directly with brain functioning and therefore with perceptual and cognitive mental abilities, thus increasing the stresses.

(d) Light, noise, discomfort, and anxiety-provoking information may interfere with sleep, which is essential to maintain brain efficiency and mental performance.

(6) Because of this intermeshing of “physical” and “mental” stressors and stress responses, no great effort needs to be invested in distinguishing them until the physical stressors reach the degree where they require specific (and perhaps emergency) protective measures and/or treatment. Prior to that point, medical and mental health personnel should assume that both physical and mental stressors are usually present

Table 1-1. Examples of Combat Stressors

PHYSICAL STRESSORS	MENTAL STRESSORS
<p style="text-align: center;"><b>ENVIRONMENTAL</b></p> <p>HEAT, COLD, WETNESS            VIBRATION, NOISE, BLAST            HYPOXIA (INSUFFICIENT OXYGEN)            FUMES, POISON, CHEMICALS            DIRECTED-ENERGY WEAPONS/DEVICES            IONIZING RADIATION            INFECTIOUS AGENTS            PHYSICAL WORK            BRIGHT LIGHTS, DARKNESS, HAZE, AND            OBSCURATIONS            DIFFICULT OR ARDUOUS TERRAIN</p>	<p style="text-align: center;"><b>COGNITIVE</b></p> <p>INFORMATION: TOO MUCH, TOO LITTLE            SENSORY OVERLOAD VERSUS DEPRIVATION            AMBIGUITY, UNCERTAINTY, ISOLATION            TIME PRESSURE VERSUS WAITING            UNPREDICTABILITY            RULES OF ENGAGEMENT, DIFFICULT            JUDGMENT            ORGANIZATIONAL DYNAMICS            HARD CHOICE VERSUS NO CHOICE            RECOGNITION OF IMPAIRED FUNCTIONING</p>
<p style="text-align: center;"><b>PHYSIOLOGICAL</b></p> <p>SLEEP DEBT            DEHYDRATION            MALNUTRITION, POOR HYGIENE            MUSCULAR AND AEROBIC FATIGUE            IMPAIRED IMMUNE SYSTEM            OVERUSE OR UNDERUSE OF MUSCLES            ORGAN SYSTEMS            ILLNESS OR INJURY</p>	<p style="text-align: center;"><b>EMOTIONAL</b></p> <p>FEAR- AND ANXIETY-PRODUCING THREATS            (OF DEATH, INJURY, FAILURE, LOSS)            GRIEF-PRODUCING LOSSES (BEREAVEMENT)            RESENTMENT, ANGER- AND RAGE-PRODUCING            FRUSTRATION, THREAT, LOSS, AND GUILT            BOREDOM-PRODUCING INACTIVITY            CONFLICTING MOTIVES (WORRIES ABOUT HOME,            DIVIDED LOYALTIES)            SPIRITUAL CONFRONTATION OR TEMPTATION            CAUSING LOSS OF FAITH            INTERPERSONAL FEELINGS</p>

and interacting. They should treat both types of stressors simultaneously as standard procedure.

*d. Positive Stress.* Positive stress is that degree of stress which is necessary to sustain and improve tolerance to stress without overstraining and disrupting the human system. Some level of stress is helpful and even necessary to health. Insufficient stress leads to physical and/or mental weakness. A moderate response to stress actually improves performance. Soldiers who have been trained to manage their responses to a stressful situation by maintaining neither too low nor too high a level of activation perform tasks better. Progressively greater exposure to a

physical stressor, sufficient to produce more than "routine" stress reflexes, is often required to achieve greater tolerance or acclimatization to that stressor. Well-known examples are cardiovascular and muscle fitness and heat and cold acclimatization. Stressors which overstrain the human system can clearly retard acclimatization and even permanently impair it. For instance, in the "physical stress" example given, excessive physical work can cause temporary or permanent damage to muscles, bones, and heart, while extreme heat and cold can cause heatstroke or frostbite with permanently reduced tolerance to heat or cold. The same may be true of emotional or mental

stress, although the mechanism is less clear. Up to a point, mental stress (even uncomfortable or painful mental stress) may increase tolerance to future stress without any current impairment. A higher level may cause temporary overtrain but may heal as strong or stronger than ever with rest and restorative processing. More severe overstrain, however, may severely weaken tolerance to future stress. There is reason to believe that immediate treatment can greatly reduce the potential for chronic disability, even for impairing emotional overstrain.

### 1-3. Stress Behaviors in Combat

a. *Combat Stress Behaviors.* Combat stress behavior is the generic term which covers the full range of behaviors in combat, from highly positive to totally negative. Table 1-2 provides a listing of positive stress responses and behaviors, plus two types of dysfunctional combat stress behaviors—those which are misconduct stress behaviors and those which are labeled BF.

b. *Positive Combat Stress Behaviors.* Positive combat stress behaviors include heightened alertness, strength, endurance, and tolerance to discomfort. Both the fight or flight stress response and the stage of resistance can produce positive combat stress behaviors when properly in tune. Examples of positive combat stress behaviors include—

- The strong personal trust, loyalty, and cohesiveness (called horizontal bonding) which develops among peers in a small military unit.
- The personal trust, loyalty, and cohesiveness (called vertical bonding) that develops between leaders and subordinates.
- The sense of pride and shared identity which soldiers develop with the unit's

history and mission (this sense is called unit esprit de corps or simply esprit).

The above positive combat stress behaviors combine to form unit cohesion—the binding force that keeps soldiers together and performing the mission in spite of danger and death. The ultimate positive combat stress behaviors are acts of extreme courage and almost unbelievable strength. They may even involve deliberate self-sacrifice. Positive combat stress behaviors can be brought forth by sound military training, wise personnel policies, and good leadership. The results are behaviors which are often rewarded with praise and individual and/or unit recognition. For additional information on positive combat stress behaviors, see FM 22-51.

c. *Misconduct Stress Behaviors.* Examples of misconduct stress behaviors are listed in the center column of Table 1-2. These range from minor breaches of unit orders or regulations to serious violations of the Uniform Code of Military Justice (UCMJ) and the Law of Land Warfare. As misconduct stress behaviors, they are most likely to occur in poorly trained, undisciplined soldiers. However, misconduct can also be committed by good and even heroic soldiers under extreme combat stress. In fact, misconduct stress behaviors can become the second edge of the double-edged sword of highly cohesive and proud units. Such units may come to consider themselves entitled to special privileges and as a result, relieve tension unlawfully when they stand-down from their combat mission. They may lapse into illegal revenge when a unit member is lost in combat. Such misconduct stress behaviors can be prevented by stress control measures, but once serious misconduct has occurred, soldiers must be punished to prevent further erosion of discipline. Combat stress, even with heroic combat performance, cannot justify criminal misconduct. Combat stress may, however, constitute extenuating circumstances for minor (noncriminal) infractions in determining

Table 1-2. Combat Stress Behaviors

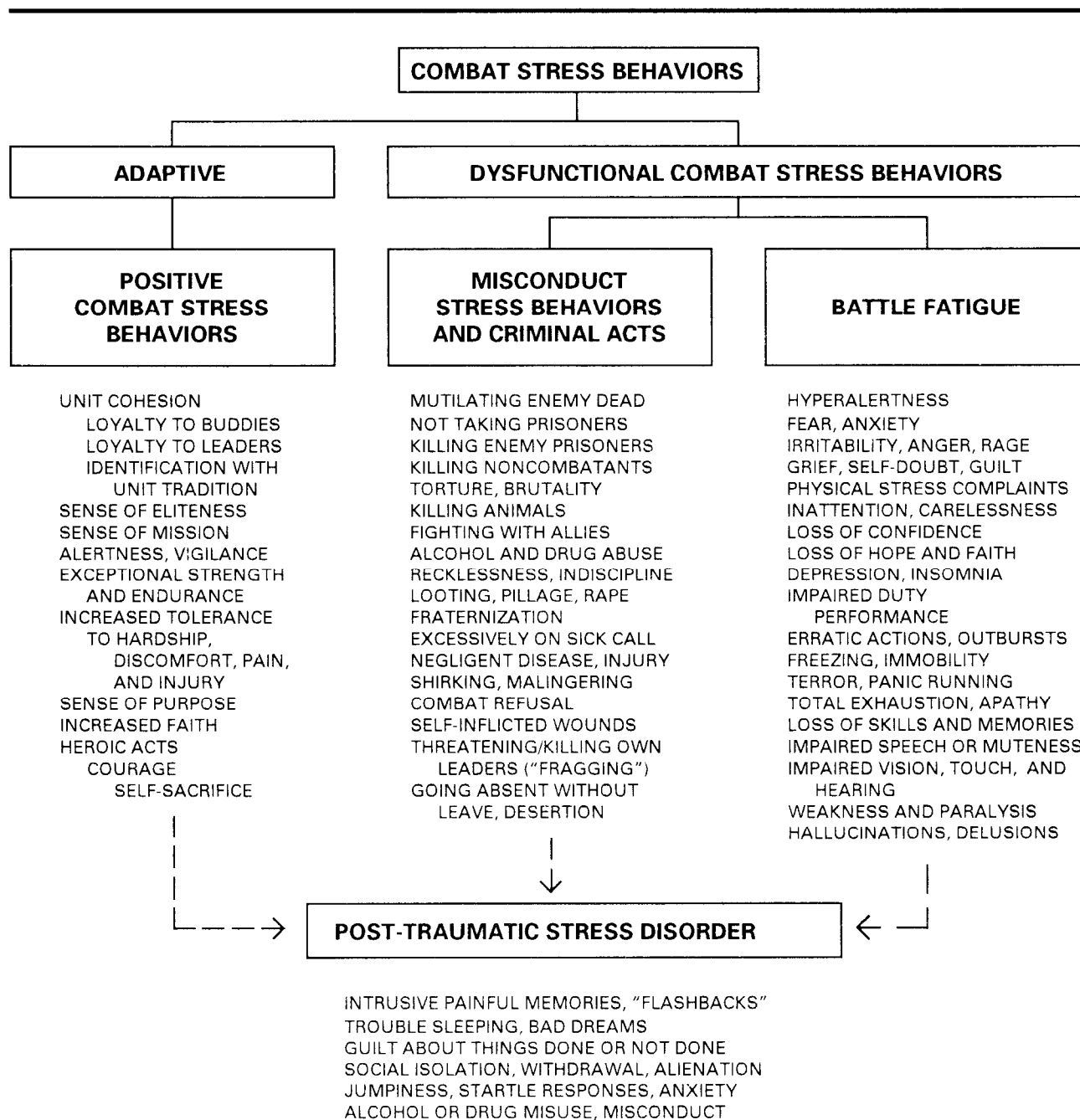

nonjudicial punishment under Article 15, UCMJ. Combat stress may also constitute an extenuating circumstance in the sentencing proceedings of a court-martial. See FM 22-51 for additional information on misconduct stress behaviors.

*d. Battle Fatigue.* Battle fatigue is also called combat stress reaction or combat fatigue. Fatigue by definition is the distress and impaired performance that comes from doing something (anything) too hard and/or too long. The term *battle fatigue* is applied to any combat stress reaction which is treated. All BF is treated (as all types of fatigue) with the four Rs—

- Reassurance of normality.
- Rest (respite from the work).
- Replenish physiologic status.
- Restore confidence with activities.

ties.

See Table 1-2 for examples of BF. The BF behaviors which are listed near the top may accompany excellent combat performance, and are often found to some degree in all soldiers. These are normal, common signs of BF. Those behaviors that follow are listed in descending order to indicate progressively more serious warning signs. Warning signs deserve immediate attention by the leader, medic, or buddy to prevent potential harm to the soldier, others, or the mission. If the soldier responds quickly to helping actions, warning signs do not necessarily mean he must be relieved of duty or evacuated. However, he may require further evaluation at an MTF to rule out other physical or mental illness. If the symptoms of BF persist and make the soldier unable to perform duties reliably, then MTFs, such as clearing stations and specialized CSC teams, can provide restorative treatment. At this point, the soldier is a BF casualty. For those cases, prompt treatment

close to the soldier's unit provides the best potential for returning the soldier to duty. Recovered BF casualties who are accepted back in their units are at no more risk of recurrence than their fellow soldiers.

*e. Overlapping of Combat Stress Behaviors.* The distinction between positive combat stress behaviors, misconduct stress behaviors, and BF is not always clear. Indeed, the three categories of combat stress behaviors may overlap. Soldiers with BF may show misconduct stress behaviors and Vice versa. Soldiers who exemplify the positive combat stress behaviors may suffer symptoms of BF and may even be BF casualties before or after their performance of duty. Excellent combat soldiers may commit misconduct stress behaviors in reaction to the stressors of combat before, after, or during their otherwise exemplary performance. However, combat stress, even with good combat behaviors, does not excuse criminal acts.

*f. Post-Traumatic Stress Disorders.* Symptoms of post-traumatic stress are persistent or recurring stress responses after exposure to extremely distressing events. As with BF, post-traumatic stress symptoms can be normal/common signs or warning signs. These signs and symptoms do not necessarily make the soldier a casualty nor does the condition warrant the label of a disorder. This becomes PTSD only when it interferes with occupational or personal life goals. These signs and symptoms sometime occur months or years after the event and may include—

- Painful memories.
- Actions taken to escape painful memories such as—
  - Substance abuse.
  - Avoidance of reminders of the traumatic event.

- Social estrangement.
- Withdrawal.

Post-traumatic stress disorder often follows inadequately treated BF. It often follows misconduct stress behaviors in those who committed misconduct under stress, as well as in the victims, reluctant participants, caregivers, and observers. Post-traumatic stress disorder can occur in soldiers who showed no maladaptive stress behaviors at the time of the trauma. Post-traumatic stress disorders can occur or recur years after the event, usually at times of excessive stress. In addition to their primary mission during war, leaders, chaplains, and medical and CSC personnel have the additional responsibility of preventing or minimizing subsequent PTSD. The most important preventive measure for PTSD is routine after-action debriefing in small groups. If properly debriefed, soldiers will often not develop clinical PTSD or misconduct stress behaviors. Experiences of excessive stress can be accepted and diverted into positive growth. For additional information on PTSD, its prevention, and treatment, see FM 22-51.

#### 1-4. Stressors and Stress in Army Operations

a. *The Changing Focus.* The emerging concept for Army operations in the post-cold war era has reoriented the nation's military capability away from a primary focus on potential large scale war against Soviet forces in Europe. The focus has shifted towards a more ambiguous threat from current or future regional powers around the world.

(1) High technology weapons are available from a number of sources throughout the world. The dissolution of the Soviet empire may disperse quantities of high technology weapons (and weapons design expertise) to

ambitious countries who are hostile toward the US or toward nations important to the US. Consequently, the danger of regional armor-heavy battles at the high-intensity end of the continuum of conflict, and even of regional nuclear, biological, and chemical (NBC) war, may paradoxically increase over the next decades.

(2) Alternatively, hostile states (or ethnic/religious factions encouraged by them) may attempt to overthrow friendly nations or attack the US interest by conducting terrorist or insurgency operations. These attacks may require counteractions by US combat forces. In operations other than war (OOTW), contingency operations may be needed to protect US lives, property, and international standards of humane conduct in third world countries which are otherwise of little concern to the US. These operations will likely be conducted on short notice, under conditions of high operational security. They will also be subject to intense and near-instantaneous media coverage.

b. *High-Technology Joint and Coalition Operations.* Most combat and contingency operations will be joint operations. Many will involve working in coalition with countries whose customs and culture are quite different from our own. The US will make maximal use of our technological superiority in intelligence-gathering and weapons systems to mobilize overwhelming forces at the decisive point for quick and certain victory. However, those systems can only be as effective as the stress tolerance of the human commanders and soldier/operators make them. The combining of highly lethal weapons systems from different branches, services, and allies creates an intrinsic risk of friendly fire casualties. This risk, too, must be calculated and the stress consequences controlled.

c. *Brigade Task Force Operations.* The Army operations concept makes the brigade the critical unit for CSC prevention and immediate

intervention, more so than in previous wars. Divisional and separate brigades and armored cavalry regiments (ACRs) will be combined into task forces for rapid-deployment contingency operations. Within campaigns, brigade task forces will be rapidly organized for specific, brief, violent battles. During battles, the task forces can cover great distances quickly, concentrate for decisive action, and perhaps reconstitute at different tactical support areas than the ones from where they started. Between battles, brigades may remain widely dispersed. A brigade which is armed with modern weapons systems has more firepower and covers a larger area of responsibility than a World War I (WWI) or WWII division. At the small unit level, the importance of individual soldiers to the unit's combat power is also greatly increased for weapons operators and leaders. It is equally true for critical combat support (CS) and combat service support (CSS) specialists. Rear battle, in the form of long-range artillery fire, enemy airborne/air assault units, guerrilla activity, air interdiction, and terrorist or missile attacks, may strike far behind the battle area. Army mental health/CSC organization and doctrine were first designed to support WWI and WWII divisions. Our new mental health/CSC doctrine and units must adapt to these changing conditions by assuring integral CSC support at brigade level while improving coverage throughout the supported area.

*d. Military Operations Other Than War.* In addition to war, there will be many other Army missions which are prolonged. The National Command Authority may commit US Army units to military OOTW including—

- Conflict.
- Nation assistance.
- Security assistance.
- Humanitarian assistance and disaster relief.

- tions.
  - Support to counter drug operations.
  - Peacekeeping operations.
  - Arms control.
  - Combatting terrorism.
  - Show of force.
  - Attacks and raids.
- operations.
  - Noncombatant evacuation operations.
  - Peace enforcement.
  - Support for insurgences and counterinsurgencies.
  - Support to domestic civil authorities.

The rules of engagement for each of the above operations are unique to that situation. Requirements to maintain neutrality provide a show of force only, engage in constructive humanitarian, or other such actions may require that only defensive actions be taken once attacked. In conflict, however, the opponents may deliberately seek to provoke our forces into committing misconduct stress behaviors. By committing criminal acts, the role of the US Forces would be degraded in the eyes of local, US, and world populations. In light of this, the CSC role in the prevention of misconduct stress behaviors is extremely important. For definitive information pertaining to OOTW, see FM 100-5.

*e. Neuropsychiatric Disorders.* The focus of CSC is on the prevention and treatment of stress-induced disability in otherwise normal soldiers. Mental health/CSC personnel, by virtue of their professional training and experience, are



also best qualified to diagnose, treat, and recommend RTD or disposition for the endemic neuropsychiatric (NP) disorders. These NP disorders include the schizophrenic-type psychotic disorders, mood disorders, anxiety disorders, organic mental disorders, personality disorders, and substance abuse disorders. These NP disorders are significant impediments to combat readiness and also to peacetime training. Sound prevention and screening programs as identified in Army Regulation (AR) 40-216, as well as early recognition and treatment, assist the command in maintaining the fighting strength.

### 1-5. Army Combat Stress Control

*a. Focus of Army Combat Stress Control.* The focus of Army CSC is toward—

- Promotion of positive mission-oriented motivation.
- Prevention of stress-related casualties.
- Treatment and early RTD of soldiers suffering from BF.
- Prevention of harmful combat stress reactions such as misconduct stress behaviors and PTSD.

*b. Implementation.* The CSC program is implemented by mental health/CSC personnel organic to the divisions, the medical companies of separate brigades, and the area support medical battalions (ASMBS) in the corps and communications zone (COMMZ) (see Chapters 2 and 3). These mental health/CSC personnel are augmented by the CSC company or detachment. Combat stress control companies and detachments are assigned to the corps and in the COMMZ (see Chapters 2 and 3). Primary goals of mental health/CSC personnel when implementing this program are to—

- Monitor stressors and stress in units.
- Advise command on measures to reduce or control stress and stressors before they cause dysfunction.
- Reduce combat stress-related casualties by training leaders, medical personnel, chaplains, and soldiers on stress-coping techniques.
- Promote positive combat stress behavior and progressively increase stress tolerance to meet the extreme stress of combat.
- Recognize and treat BF and other stress reactions as early and as far forward as possible.
- Accomplish the earliest RTD of most soldiers who become stress-related casualties.
- Facilitate the correct disposition of soldiers whose BF, misconduct stress behaviors, and NP disorders do not allow RTD.
- Reduce PTSD, chiefly by training and assisting after-action debriefings and by leading critical event debriefings.

### 1-6. Historical Experience

The AMEDD identified "CSC" as a separate functional mission area in 1984, but CSC is not new. Historical experience in the Civil War, WWI, WWII, Korea, Vietnam, the Arab-Israeli, and other wars has demonstrated the basic principles of combat psychiatry and combat mental health. The goal is to preserve the fighting strength by minimizing losses due to BF and NP disorders.

a. *World War I.* In 1917, before sending the American Expeditionary Force to Europe, the US Army sent a medical team to see what our new allies had learned from hard experience about casualty care. Based on the finding of this team in the combat psychiatry area, The Surgeon General of the Army recommended that we adopt a three-echelon system similar to that of the British Army. He also recommended that we implement their policies to return soldiers with “war neurosis” (commonly mislabeled *shell shock*) to duty. Accordingly, in WWI, we assigned a psychiatrist to each division (first echelon) to train the unit leader and medical personnel. The psychiatrist trained unit leaders and medical personnel to recognize and treat simple fatigue cases in their own units. Many US stress casualties were returned to duty after resting a few days in the 150-cot field hospital which was located in the division rear. By direction of The Surgeon General’s NP consultant, the official diagnostic label for these types of cases while the soldier was still in the division area was “Not Yet Diagnosed, Nervous,” (also adapted from the British and abbreviated NYDN). The psychiatrist screened out and evacuated soldiers with serious NP disorders. Behind the division (second echelon), we had special neurological hospitals (150-bed facilities with psychiatrist supervisors). They treated the relatively few NYDN cases who did not RTD within the division in a few days. They also treated some soldiers with “gas mania,” who believed they had been gassed when in fact they had not been. Further to the rear, we had Base Hospital 117 (third echelon), staffed by psychiatrists, nurses, specially trained medics, and occupational therapists. These medical professionals salvaged many soldiers who did not fully recover in the neurological hospitals. This three-echelon system worked well. However, on occasions when the tactical situation interfered with forward treatment, it clearly showed the importance of treating the soldiers close to their units. Overall, a large percent of WWI “war neurosis” cases were RTD.

b. *World War II.* During the time between WWI and WWII, CSC insights and the principles learned were forgotten. It was believed that prior screening could identify and exclude most of the soldiers who would be prone to psychoneurosis and breakdown in combat. That screening was glaringly unsuccessful. The WWI system was reinstated during the Tunisia campaign, and the condition formerly identified as “war neurosis” was officially labeled *combat exhaustion*. By late in the war, the Mediterranean and European theaters again had psychiatrists assigned to each division. Most maneuver battalions had “rest centers” in their “kitchen trains” (where recovering soldiers were monitored by the battalion surgeon). There were “exhaustion centers” in the regimental or combat team trains area, monitored by the regimental surgeon. The division psychiatrist trained the regimental and battalion surgeons in combat psychiatry. During combat, the psychiatrist triaged and treated combat exhaustion cases at the division clearing company and supervised their further rehabilitation for 3 to 5 days at the division’s “training and rehabilitation center.” There were also (once again) Army NP centers (clearing companies with psychiatric supervisors and specially trained staff) behind the divisions. Psychiatric consultants were at Army level, and specialized base hospitals were located in the COMMZ. In heavy fighting during WWII, some divisions had one BF casualty for every five, three, even two WIAs. However, highly trained and cohesive units rarely had more than one BF casualty for ten WIA. That ratio illustrated the value of strong leadership in preventing BF even under conditions of extreme stress.

c. *Korea.* In each division, the division psychiatrist was assisted by a social work specialist and a clinical psychologist specialist (initially, enlisted specialists; later officers). These professionals functioned very effectively in treating combat exhaustion (what is now referred to as BF). It should be stated that there was

some confusion during the initial hasty mobilization and deployment and many combat exhaustion cases were inadvertently evacuated to Japan. The lessons of WWII were institutionalized in a specialized unit, the "KO Team" (medical detachment, psychiatric). The primary mission of this mobile unit was to augment a medical clearing company and make it into an NP center. Late in the conflict, 85 percent of the BF cases returned to combat within 3 days. An additional 10 percent returned to limited duty in several weeks, and only 5 percent were evacuated to CONUS.

*d. Vietnam.* In Vietnam, division mental health sections were located and worked at the main base camp areas. They sometimes sent consultation teams or enlisted behavioral science specialists to visit base camps and fire bases. Many of these draftee mental health personnel were professionals with masters- or doctorate-level degrees. Traditional "combat exhaustion" was rarely seen, and most cases of BF were handled within the units. Substance abuse, the lack of discipline, and even commission of atrocities were significant problems but were not clearly recognized as misconduct stress behaviors. By mid-1971, 61 percent of all medical evacuations from Vietnam were NP patients (mostly substance abuse). Two KO Teams served with distinction in Vietnam, but because of the different nature of war, functioned mostly as psychiatric augmentation to an evacuation hospital and as mobile consultation teams. In 1972, based on the Vietnam experience, the KO Team was redesigned into the OM Team.

*e. Operation Desert Shield/Storm.* Beginning in September of 1990, stress assessment teams from the US Army Medical Research and Development Command were deployed in support of Operation Desert Shield. These teams conducted surveys of many combat, CS, and CSS units in the TO. These stress assessment teams used small group interviews and questionnaire

surveys to assess the soldiers' level of unit cohesion and their self-perceived readiness for combat. The stress assessment teams provided feedback to units and to the Army Central Command on how to control stress and enhance morale and readiness. They also provided training to leaders and troops on stress control. Corps- and theater-level OM Teams reached the theater in late October and December. The mobile teams actively undertook the command consultation and training mission to corps and echelon above corps units. They reinforced the activities of the division mental health sections. During Operation Desert Storm, division mental health/CSC teams were deployed forward. These teams worked with units who had suffered casualties. Combat stress control teams from the corps were deployed behind the brigades. These teams saw few stress casualties during the ground offensive because of its rapid and highly victorious pace which lasted only 100 hours. During demobilization after Operation Desert Storm, a systematic effort was conducted by chaplains and mental health personnel to prepare soldiers and their families for the changes and stressors of reunion. Some units which had especially difficult experiences received special debriefings.

## 1-7. Principles of Combat Psychiatry

The basic precepts of combat psychiatry have been documented in every US war in this century. Our allies through similar experiences have further documented these basic precepts. The principles of combat psychiatry are—

### *a. Maximize Prevention.*

*(1) Achieve primary prevention.* Control (and when feasible, reduce) stressors which are known to increase BF and misconduct stress behaviors. Some of the factors which increase stress and stress casualties include—

time in combat) in a unit.

- Being a new soldier (first time in combat) in a unit.
- Home front worries.

killed in action (KIA) and WIA.

- Intense battle with many killed in action (KIA) and WIA.

tic training.

- Insufficient tough, realistic training.
- Lack of unit cohesion.

equipment, and supporting arms.

- Lack of trust in leaders, equipment, and supporting arms.

- Sleep loss.

ing (dehydration, malnutrition).

- Poor physical conditioning (dehydration, malnutrition).

tal exposure.

- Debilitating environmental exposure.

- Inadequate information.

tainty and ambiguity.

- High degree of uncertainty and ambiguity.

end of the mission in sight.

- Absence of an achievable end of the mission in sight.

pose.

- Inadequate sense of purpose.

**(2) Achieve secondary prevention.**

Minimize acute disability (morbidity) by training leaders, chaplains, and medical personnel to—

signs and symptoms of BF/combat stress or misconduct stress.

- Identify early warning signs and symptoms of BF/combat stress or misconduct stress.

with the soldiers to treat the warning symptoms and control the relevant stressors.

- Intervene immediately with the soldiers to treat the warning symptoms and control the relevant stressors.

Prevent contagion by rapidly segregating and treating dramatic BF casualties and disciplining minor misconduct stress behaviors.

- Prevent contagion by rapidly segregating and treating dramatic BF casualties and disciplining minor misconduct stress behaviors.

Reintegrate recovered BF casualties back into their units.

- Reintegrate recovered BF casualties back into their units.

Taking and publicizing appropriate disciplinary actions for criminal misconduct stress behaviors.

- Taking and publicizing appropriate disciplinary actions for criminal misconduct stress behaviors.

**(3) Achieve tertiary prevention.**

Minimize the potential for chronic disability (PTSD), both in soldiers who show BF and those who do not. This is done by—

Having an active preventive program (debriefings) during and immediately after combat and/or traumatic incident.

- Having an active preventive program (debriefings) during and immediately after combat and/or traumatic incident.

Conducting end of tour debriefings for units and unit members' families.

- Conducting end of tour debriefings for units and unit members' families.

Remaining sensitive to delayed or covert post-traumatic stress signs and symptoms and providing positive intervention. (This is primarily the role of leaders, chaplains, and health care providers.)

- Remaining sensitive to delayed or covert post-traumatic stress signs and symptoms and providing positive intervention. (This is primarily the role of leaders, chaplains, and health care providers.)

*b. Treat Battle Fatigue.* Proximity, immediacy, expectancy, and simplicity (PIES) are all extremely important in the treatment of BF.

**(1) Proximity.** Proximity refers to the need of treating soldiers as close to their units and the battle as possible. It is a reminder that overevacuation should be prevented.

**(2) Immediacy.** Immediacy indicates that BF requires treatment immediately.

**(3) Expectancy.** Expectancy relates to the positive expectation provided to BF casualties for their full recovery and early RTD.

(4) *Simplicity.* Simplicity indicates the need for using simple, brief, straightforward methods to restore physical well-being and self-confidence by using nonmedical terminology and techniques.

c. *Make Differential Diagnosis, But Defer Psychiatric Diagnosis.* Distinguish life- or function-threatening medical or surgical conditions as soon as possible and provide those patients emergency treatment. Treat all others using PIES to the safest maximum extent possible. Let the response to treatment sort out the true NP disorders. The nonresponders should be evacuated to the echelon of care appropriate for their treatment (either COMMZ or CONUS facilities) where treatment continues and the final diagnosis is determined.

## 1-8. Generic Treatment Principles for Battle Fatigue

The generic treatment principles provided below apply at all echelons throughout the TO. Their applications may differ based on a particular echelon and other factors pertaining to the mission, enemy, terrain, troops, and time available (METT-T).

a. *Initial Assessment.* In the initial assessment, a brief but adequate medical and mental status examination is performed. This examination should be appropriate to the echelon of care and should rule out any serious physical mental illness or injury. Always consider the possibility of trauma to the head or trunk. Other surgical, medical, NP, and drug and alcohol misuse disorders may resemble BF, but they require emergency treatment. It is important to recognize symptoms to avoid performing unnecessary tests. Often it is best to treat for BF while covertly observing for other more serious conditions.

b. *Reassure.* At every echelon, give immediate, explicit reassurance to the soldier. Explain to him that he has BF and this is a temporary condition which will improve quickly. Actively reassure everyone that it is neither cowardice nor sickness but rather a normal reaction to terribly severe conditions. Provide these soldiers with the expectation that they will be RTD after a short period of rest and physical replenishment and involve them in useful activities, as appropriate.

c. *Separate.* Keep BF soldiers separated from those patients with serious medical, surgical, or NP conditions. This is done because association with serious medical, surgical, or psychiatric patients often worsens symptoms and delays recovery. Those few BF casualties who show overly dramatic symptoms of panic anxiety, depression, and/or physical or memory problems need to be kept separate from all other types of patients (including other BF casualties). This is done until those symptoms cease so as not to adversely affect other BF soldiers.

### NOTE

Association of recovering BF casualties with *hold for treatment* (patients expected to RTD within 72 hours) cases who have minor injury or illness is not harmful.

No sharp distinction should be made between other convalescent soldiers and those recovering from BF. Indeed, many of the soldiers with minor wounds or illnesses also have BF and should be treated with the principles of PIES. These soldiers can be treated together provided they are not in their "contagious" stage and RTD for both is imminent.

d. *Simple Treatment with Rest and Replenishment.* Keep treatment for BF deliberately

simple. Provide relative relief from danger but maintain a tactical atmosphere which is not too comfortable. Provide rehydration, sleep, and hygiene.

*e. Restore Confidence.* Restore confidence by structured military work details, physical exercise, and recreation. Get the soldier to talk about what happened to him. Provide supportive counseling as needed to clarify memories, to provide the opportunity to express feelings, and to regain perspective. Reinforce the soldier's identity as a soldier and a member of his unit, not as a patient.

*f. Avoid Sedatives and Tranquilizing Medications.* Avoid sedative or tranquilizing medication unless essential to manage sleep or agitated behavior. The BF soldier needs to maintain a normal state of alertness, coordination, and understanding. If the BF soldier is not medicated, he can take care of himself and can respond to and accept his treatment.

*g. Evacuation and Hospitalization.* Do not evacuate or hospitalize BF casualties unless absolutely necessary. Evacuation and hospitalization delay recovery and significantly increase chronic morbidity, regardless of the severity of the initial symptoms. It is better to transport BF casualties in general-purpose vehicles, not ambulances (and especially not air ambulances), unless no other means of transportation is feasible. Evacuation should be approved by a single qualified authority (for example, if the soldier is to leave the division, by the division psychiatrist, in accordance with AR 40-216).

*h. Unmanageable Cases.* Soldiers whose BF (or psychiatric) symptoms make them too disruptive to manage at a given echelon should be evacuated only to the next higher echelon with the expressed positive expectation of improvement. The next higher echelon will reevaluate the soldier for manageability. However, be

careful not to let "unmanageability" become well-known as the criteria for "escape by evacuation," since that could lead others to follow the bad example.

*i. Manageable Battle Fatigue, but Unresponsive to Initial Treatment.* Those manageable BF casualties who (after initial treatment) do not improve sufficiently within the allotted time to RTD are also sent unobtrusively back to the next higher echelon, with expressed positive expectations for further treatment. This sustains the positive expectation of rapid recovery for BF casualties who are just arriving.

*j. Hospitalization.* As stated above, do not hospitalize a BF casualty unless absolutely necessary for safety. Those BF casualties who do require brief hospitalization for differential diagnosis or acute management should be transferred to a nonhospital treatment setting as soon as their conditions permit. Those who reach hospitals as an inappropriate evacuee should be told they are only experiencing BF; they should be returned to their unit area or other forward area as soon as possible to recover in a nonhospital facility.

*k. Restoration and Reconditioning.* Ideally, BF casualties are not evacuated to CONUS without having had an adequate restoration and/or reconditioning trial in both the combat zone (CZ) and the COMMZ. The treatment strategies of these programs assist recovering BF soldiers in regaining skills and abilities needed for combat duty. These skills and abilities include concentration, team work, work tolerance, psychological endurance, and physical fitness. Restoration is a 1- to 3-day program which is conducted in both the division and the corps areas. Restoration is normally conducted by the medical detachment, CSC and/or the mental health section in the division. In the corps area, restoration is conducted by the medical detachment, CSC and/or the mental

health section of the ASMB. Reconditioning is a 7- to 14-day program that requires hospital admission for accountability of BF cases. It is conducted in a nonhospital setting by the medical company, CSC in both the corps and COMMZ.

### 1-9. Combat Stress Control Functional Mission Areas

a. *Functional Roles.* The principles of combat psychiatry and the methods for prevention and treatment of BF are exercised in six functional mission areas for mental health/CSC personnel and units. These functional mission areas have differing priorities depending on the situation. They are defined below and are analyzed in detail in subsequent chapters of this manual.

(1) *Consultation.* Consultation involves the liaison and preventive advice and assistance to commanders and staff of supported units (see Chapter 4).

(2) *Reconstitution support.* Reconstitution support is that assistance provided to attrited units at field locations. Reconstitution is an extraordinary action that commanders plan and implement to restore units to a desired level of combat effectiveness commensurate with mission requirements and available resources according to FM 100-9. Reconstitution is a total process which involves the sequence of reorganization, assessment, and regeneration. Mental health/CSC personnel support reconstitution as a part of a consolidated team (see Chapter 5).

(3) *Combat neuropsychiatric triage.* Combat NP triage (as distinguished from surgical triage) is the process of sorting combat stress-related casualties and NP patients into categories based on how far forward they can be treated. These categories are DUTY (RTD immediately), REST (light duty for 1 to 2 days in

their unit's own CSS elements), HOLD (requires medical holding at this echelon for treatment), and REFER (requires evacuation to the next higher echelon for further evaluation and treatment) (see Chapter 6).

(4) *Stabilization.* This function provides stabilization of severely disturbed BF and NP patients. They are evaluated for RTD potential or prepared for further treatment or evacuation, if required (see Chapter 7).

(5) *Restoration.* Restoration involves treatment with rest, food, water, hygiene, and activities to restore confidence within 1 to 3 days at forward medical facilities. Between 55 and 85 percent of BF casualties should RTD with restoration treatment (see Chapter 8).

(6) *Reconditioning.* Reconditioning involves treatment with physical training and an intensive program of psychotherapy and military activities. Reconditioning programs are conducted for 7 or more days in a nonhospital setting in the corps area. Additional reconditioning may be provided in the COMMZ (see Chapter 9). No more than 5 to 10 percent of BF casualties should eventually be evacuated to CONUS.

#### NOTE

All CSC functions since WWII except reconstitution support were successfully demonstrated repeatedly. Although the terminology has changed, the functions remain the same. Reconstitution support has been identified as a separate mission to meet the special hazards and requirements of war.

b. *Priority of Functional Mission Areas.* The six functional mission areas listed above are in the usual order of their doctrinal

priority for allocation of assets when workloads exceed resources. However, the functions have different relative importance in different scenarios or phases of the operation. The CSC commander must set priorities and allocate resources to accomplish missions in each program based

upon the total situation. Subsequent chapters of this manual will discuss each of the functional areas and provide basic TTP for accomplishing them. These chapters will also address how CSC functional areas interface with other functional areas.



**★ FOR INFORMATION ON MENTAL HEALTH AND COMBAT STRESS CONTROL ELEMENTS  
REORGANIZED UNDER THE MRI, SEE APPENDIX E.**

CHAPTER 2

**MENTAL HEALTH AND COMBAT STRESS CONTROL  
ELEMENTS IN THE THEATER OF OPERATIONS**

**Section I. UNIT MENTAL HEALTH SECTIONS IN THE THEATER**

**2-1. Locations and Assignments of Unit  
Mental Health Sections**

Mental health sections are located in the divisions, the corps, and the COMMZ. In the divisions, they are assigned to the medical company of the main support battalion (MSB). In the corps and COMMZ, they are assigned to the ASMB headquarters. In separate brigades, they are assigned to the medical company.

**2-2. Division Mental Health Section**

The division mental health section is assigned to the main support medical company (MSMC), which is a division support command (DISCOM) asset (see FMs 8-10-1, 8-10-3, and 63-21).

**NOTE**

The responsibilities of the division mental health section extend to all division elements and require a mental health/CSC presence at the combat maneuver brigades.

The division mental health section is the medical element in the division with primary responsibility for assisting the command in controlling combat stress. Combat stress is controlled through sound leadership, assisted by CSC training, consultation, and restoration programs conducted by this section. The division mental health section enhances unit effectiveness and minimizes losses due to BF, misconduct stress behaviors, and NP disorders. Under the direction of the division psychiatrist, the division mental health

section provides mental health/CSC services throughout the division. This section, acting for the division surgeon, has staff responsibility for establishing policy and guidance for the prevention, diagnosis, treatment, and management of NP, BF, and misconduct stress behavior cases within the division area of operations (AO). It has technical responsibility for the psychological aspect of surety programs. The staff of this section provides training to unit leaders and their staffs, chaplains, medical personnel, and troops. They monitor morale, cohesion, and mental fitness of supported units. Other responsibilities for the division mental health section staff include—

- Monitoring indicators of dysfunctional stress in units.
- Evaluating NP, BF, and misconduct stress behavior cases.
- Providing consultation and triage as requested for medical/surgical patients exhibiting signs of combat stress or NP disorders.
- Supervising selective short-term restoration for HOLD category BF casualties (1 to 3 days).
- Coordinating support activities of attached corps-level CSC elements.

The division mental health section normally collocates with the MSMC clearing station. For a listing of major equipment assigned, see Appendix A. The staffing of the division mental health section allows for this section to be split into teams which deploy forward to provide CSC support, as required, to

brigades in the division. Normally, each brigade is supported by a brigade CSC team. This team consists of a mental health officer who is designated the brigade mental health officer and a behavioral science NCO that is designated the brigade CSC coordinator. If no mental health officer is available, the senior behavioral science noncommissioned officer in charge (NCOIC) substitutes as the brigade CSC team leader. The division psychiatrist oversees all brigade CSC teams and provides consultation as necessary.

*a. Mental Health/Combat Stress Control Support.* The division psychiatrist provides input to the division surgeon on CSC-related matters. He works with the division medical operations center (DMOC) to monitor and prioritize mental health support missions in accordance with the division combat health support (CHS) operation plans (OPLANs) or operation orders (OPORDs). Coordination for mental health personnel augmentation is accomplished through the MSB Operations and Training Officer (US Army) (S3) and the DMOC.

*b. Division Mental Health Section Staff.* The division mental health section is staffed as shown in Figure 2-1. The consolidation of assigned mental health officers and behavioral science specialists in one division mental health section provides unity of CSC support for all division prevention, training, and treatment responsibilities of the section. It provides multi-disciplinary mental health professional expertise to—

- Supervise and train the behavioral science NCOs and specialists.
- Provide staff input to the commands within the division AO.
- Assure clinical evaluation and supervision of treatment for all NP and problematic BF cases before they leave the division.

- Maintain communications and unity of efforts when division mental health section personnel are dispersed to the brigades.

- Provide the points of contact to integrate reinforcing CSC teams throughout the division.

DIVISION MENTAL HEALTH SECTION STAFF
Psychiatrist
Clinical Psychologist
Social Work Officer
Senior Behavioral Science NCO (NCOIC, E-7)
Behavioral Science NCO (E-6)
Behavioral Science Sergeant (E-5) (two)
Behavioral Science Specialist (three)

*Figure 2-1. Division mental health section staff.*

(1) *Psychiatrist.* The division psychiatrist (Major [MAJ], Medical Corps [MC], area of concentration [AOC] 60W00) is the officer in charge of the division mental health section. The psychiatrist is also a working physician who applies the knowledge and principles of psychiatry and medicine in the treatment of all patients. He examines, diagnoses, and treats, or recommends courses of treatment for personnel suffering from emotional or mental illness, situational maladjustment, BF (combat stress reactions), and misconduct stress behaviors. His specific functions include—

- Directing the division’s mental health (combat mental fitness) program.

- Being a staff consultant for the division surgeon on matters having psychiatric aspects, which include—

- Personnel reliability program.
- Security clearances.

- Alcohol and drug abuse prevention and control programs (ADAPCPs).

- Planning CSC support for supported units.

- Conducting mental health/CSC Operations.

- Providing staff consultation for the MSMC commander and for supported commands within the division.

- Being responsible for assuring the diagnosis, treatment, restoration, and disposition of all NP and problematic BF cases.

- Participating in the diagnosis and treatment of the sick, injured, and wounded, especially those who can RTD quickly.

- Providing consultation and training to physicians, physician's assistants, unit leaders, chaplains, and other medical personnel regarding diagnosis, treatment, and management of BF, misconduct stress behavior, and NP disorders.

- Prescribing treatment and disposition for soldiers with NP conditions.

- Providing supervision and training of assigned and attached mental health personnel.

(2) *Clinical psychologist.* The clinical psychologist (Captain [CPT], Medical Service Corps [MS], AOC 73B67) assists in the development, management, and supervision of the division's mental health (combat mental fitness) program. His special responsibilities apply to the knowledge and principles of psychology to include—

- Evaluating the psychological functioning of soldiers.

- Conducting surveys and evaluating data to assess unit cohesion and other factors related to prediction and prevention of both BF casualties and misconduct stress behaviors.

- Performing psychological and neuropsychological testing to evaluate psychological problems, psychiatric and organic mental disorders, and to screen misconduct stress behaviors and unsuitable soldiers.

- Apprising unit leaders, primary care physicians, and other clinical personnel regarding the assessment of individual and unit mental health fitness program.

- Providing consultation for unit commander and CSC coordinators (mental health NCOs working at the brigade level) regarding problem cases.

- Counseling and providing therapy or referral for soldiers with psychological problems.

- Serving as the brigade mental officer for one maneuver brigade (normally teamed with a behavioral science NCO).

(3) *Social work officer.* The social work officer (CPT, MS, AOC 73A67) assists in the development, management, and supervision of the division's mental health (combat mental fitness) program. He applies the mental health principles and his knowledge of social work in the performance of his duties. His responsibilities include—

- Evaluating the social integration of BF and misconduct stress behavior soldiers in their units and families.

- Coordinating and ensuring the return of recovered stress casualties to duty and their reintegration into their original or new units.

- Identifying and resolving organizational and social environmental factors which interfere with combat readiness.

- Ensuring support for soldiers and their families from Army and civilian community support agencies.

- Apprising unit leaders, primary care physicians, and other clinical personnel of available social service resources.

- Providing consultation to unit commanders and to division mental health section personnel regarding problem cases.

- Counseling and providing therapy or referral for soldiers with emotional psychological problems.

- Serving as brigade mental health officer for one maneuver brigade, teamed with one of the behavioral science NCOs.

(4) *Senior behavioral science non-commissioned officer.* The senior behavioral science NCO (E-7, military occupational specialty [MOS] 91G40) is the section sergeant for the division mental health section. This senior NCO assists the division psychiatrist and mental health officers in accomplishing their duties. He provides assistance with management of both the technical and tactical operations of the section and supervises subordinate members. His specific duties include—

- Keeping the division psychiatrist and mental health officers informed.

- Monitoring, facilitating, and supervising the training activities of the division mental health section.

- Monitoring and coordinating situation reports from division mental health section personnel deployed within the BSAs.

- Coordinating additional mental health support with the supporting medical detachment, CSC, or other corps-level CSC elements supporting the division.

- Supervising restoration of BF casualties at the MSMC by the patient-holding squad and division mental health section subordinate personnel.

- Serving as leader of a brigade CSC team when no mental health officer is available.

- Conducting classes on selected mental health topics for senior NCOs within the division.

(5) *Behavioral science non-commissioned officers.* There are three behavioral science NCOs (E-6, MOS 91G30 and E-5 [two], 91G20) assigned to the division mental health section. These three NCOs are brigade CSC coordinators and are deployed to the forward support medical companies (FSMCs) located in the brigade support areas (BSAs) of the division. They assist the brigade surgeons with matters pertaining to mental health/CSC. As required, the brigade CSC coordinators participate in staff planning to represent and coordinate mental health/CSC activities throughout the brigade. They are especially concerned with assisting and training—

- Small unit leaders.

- Unit ministry teams.

- Battalion medical platoons.

- Patient-holding squad and treatment squad personnel of the FSMC.

They provide training and advice in the control of stressors, the promotion of positive combat

stress behaviors, and the identification, handling, and management of misconduct stress behavior and BF soldiers. They coordinate training and support to the brigade by the mental health officers of the division mental health section. The behavioral science NCOs collect and record social and psychological data and counsel personnel with personal, behavioral, or psychological problems. Their general duties include—

- Assisting in a wide range of psychological and social services.
- Compiling caseload data.
- Providing counseling to soldiers experiencing emotional or social problems.
- Referring soldiers to specific mental health officers, physicians, or agencies when indicated.
- Assisting with group debriefings, counseling, and therapy sessions, and leading group discussions.
- Providing individual case consultation to commanders, NCOs, chaplains, battalion surgeons, and physician assistants within the supported brigade.
- Collecting information from units regarding unit cohesion and morale which include—
  - Obtaining data on disciplinary actions.
  - Collecting information with questionnaires.
  - Conducting structured interviews.
  - Collecting information on individual BF cases pertaining to the prior

effectiveness of the soldier, precipitating factors causing the soldier to have BF, and RTD potential.

When the brigades are tactically deployed, the brigade CSC coordinators use the division clearing stations operated by the FSMCs as the centers of their operations but are mobile throughout the AO. Their priority functions are to prevent unnecessary evacuations and to coordinate RTD, not to treat cases. Through the brigade surgeons they keep abreast of the tactical situation and plan and project requirements for CSC support when units are pulled back for rest and recuperation.

(6) *Behavioral science specialist.*

There are three behavioral science specialists (E-4 and E-3, MOS 91 G10). These specialists assist division mental health section officers and NCOs in gathering social and psychological data to support patient evaluation. Under the supervision of the mental health officer and NCOs, they provide initial screening of patients suffering emotional disorders. Their specific duties include—

- Providing supportive counseling for patients experiencing emotional or social problems.
- Assisting in the evaluation of emotionally and mentally impaired soldiers.
- Assessing a patient's mental status (level of functioning capacity), and his need for professional services.
- Deploying to an FSMC to assist an NCO brigade CSC coordinator or mental health officer.
- Serving as squad leader for up to 12 junior enlisted grade BF soldiers in a restoration program.

- Collecting information from units, including questionnaires, surveys, and data regarding soldiers/patients. One of these behavioral science specialists will be assigned as the CSC coordinator for the division support area (DSA).

In addition to the above duties, they operate and maintain assigned vehicles.

### 2-3. Area Support Medical Battalion Mental Health Section

The mental health section is the medical element with primary responsibility for assisting units in the corps support area in controlling combat stress. Combat stress is controlled through vigorous prevention, consultation, and restoration programs. These programs are designed to maximize the RTD rate of BF soldiers by identifying combat stress reactions and providing rest/restoration within or near their unit areas. Under the direction of the ASMB psychiatrist, the mental health section provides mental health/CSC services throughout the ASMB's AO. The mental health section collocates with the headquarters and support company (HSC) clearing station and deploys mental health/CSC personnel within the ASMB's AO (see FM 8-10-24). This section has staff responsibility for establishing policy and guidance for the prevention, diagnosis, and management of NP, BF, and misconduct stress behavior cases within the ASMB. It has technical responsibility for the psychological aspect of surety programs. The staff of this section provides training to unit leaders and their staffs, chaplains, medical personnel, and troops. They monitor morale, cohesion, and mental fitness of supported units. Other responsibilities for the mental health section staff include—

- Providing command consultation and making recommendations for reducing stressors.

- Evaluating NP, BF, and misconduct stress behavior cases.

- Providing consultation and triage as requested for patients exhibiting signs of combat stress reactions.

- Providing selective short-term restoration for HOLD category BF cases.

- Coordinating support activities with medical company, CSC elements, when attached or in support of the ASMB.

a. *Mental Health Support.* The ASMB S3 and the mental health section monitor and prioritize mental health support missions in coordination with the medical brigade/group headquarters.

b. *Mental Health Section Staff.* The ASMB mental health section is staffed as shown in Figure 2-2. For a listing of major items of equipment assigned, see Appendix A. The consolidation of assigned mental health officers and behavioral science specialists under one section in the HSC of the ASMB assures unity of the CSC support throughout the AO for prevention training and treatment responsibilities. It assures multidisciplinary mental health professional expertise to—

- Train and supervise the behavioral science NCOs and specialists.

- Provide staff input to supported commands.

- Provide clinical evaluation and supervision of treatment for all NP and problematic BF cases at a central location.

- Maintain communications with the medical brigade/group and corps resources.

- Provide selected officer expertise for brief intervention where required throughout the AO.

MENTAL HEALTH SECTION STAFF
Psychiatrist
Social Work Officer
Senior Behavioral Science NCO (NCOIC, E-7)
Behavioral Science NCO (E-6)
Behavioral Science Sergeant (E-5) (three)
Behavioral Science Specialist (three)

Figure 2-2. Area support medical battalion mental health section staff.

(1) **Psychiatrist.** The psychiatrist (MAJ, MC, AOC 60W00) is the section leader. The psychiatrist is also a working physician who applies the knowledge and principles of psychiatry and medicine in the treatment of all patients. He examines, diagnoses, and treats, or recommends courses of treatment for personnel suffering from emotional or mental illness, situational maladjustment, combat stress reaction, BF, and misconduct stress behaviors. His areas of responsibility include—

- Implementing CSC support according to the CHS plan.
- Conducting mental health CSC operations.
- Providing staff consultation for the ASMB commander and for supported commands within the supported AO. This includes the personnel reliability program, security clearances, and ADAPCPs.
- Diagnosing, treating, and determining disposition of NP, BF, and misconduct stress behavior cases.

- Participating in the diagnosis and treatment of the sick, injured, and wounded, especially of those who can RTD quickly.

- Providing consultation and training to unit leaders, chaplains, and medical personnel regarding identification and management of BF (combat stress reaction), misconduct stress behaviors, and NP disorders.

- Providing therapy or referral for soldiers with NP conditions.

- Providing supervision and training of assigned and attached mental health and CSC personnel.

(2) **Social work officer.** The social work officer (CPT, MS, 68R00) performs social work functions of providing direct services, teaching, and training. He provides consultation services for soldiers assigned to units within the ASMB's AO. The social work officer assists in the development, management, and supervision of the battalion's mental health (combat mental fitness) program for the AO. His responsibilities are to apply the knowledge and principles of social work to—

- Evaluate the social relatedness of BF and misconduct stress behavior soldiers in their units and families.
- Identify and resolve organizational and social environmental factors which interfere with combat readiness.
- Ensure support for soldiers and their families from Army and civilian community support agencies.
- Apprise unit leaders, primary care physicians, and other clinical personnel of available social service resources.

- Provide consultation to unit commanders and to mental health section personnel regarding problem cases.
- Counsel and provide therapy or referral for soldiers with psychological problems.
- Coordinate and ensure the return of BF and NP soldiers to duty and their reintegration into their original or new units.

(3) *Senior behavioral science non-commissioned officer.* The senior behavioral science NCO (E-7, MOS 91G40) is the section sergeant for the battalion mental health section. This senior NCO assists the mental health officers in accomplishing their duties. He provides assistance with management of both the technical and tactical operations of the section and supervises subordinate members. His specific duties include—

- Keeping the ASMB psychiatrist and mental health officers informed.
- Monitoring, facilitating, and supervising the training activities of the mental health section.
- Monitoring and coordinating situation reports from mental health section personnel deployed within the battalion's AO.
- Coordinating additional mental health support for the battalion's AO as directed with the medical brigade/group.
- Conducting classes on selected mental health topics for senior NCOs within the AO.

(4) *Behavioral science noncommissioned officers.* There are four behavioral science NCOs assigned to the section (one E-6, MOS 91G30, and three E-5, MOS 91 G20). The E-6 is

the assistant section sergeant and aids the section sergeant with the accomplishment of his duties. Behavioral science NCOs collect and record social and psychological data and counsel personnel with personal, behavioral, or psychological problems. All these NCOs assist with the management of the mental health section. These NCOs may be deployed with area support medical companies (ASMCs) as CSC coordinators to provide mental health/CSC support. They assist the ASMCs with matters pertaining to mental health/CSC. As required, the CSC coordinators participate in staff planning to represent and coordinate mental health/CSC activities throughout the ASMCs' AO. They are especially concerned with assisting and training—

- Small unit leaders.
- Unit ministry teams.
- Battalion medical platoons.
- Patient-holding squad and treatment squad personnel of the ASMC.

They provide training and advice in the control of stressors, the promotion of positive combat stress behaviors, and the identification, handling, and management of misconduct stress behaviors and BF soldiers. They coordinate training and support to the supported units by the mental health officers of the ASMB mental health section. The behavioral science NCOs collect and record social and psychological data and counsel personnel with personal, behavioral, or psychological problems. Their general duties include—

- Assisting in a wide range of psychological and social services.
- Compiling caseload data.
- Providing counseling to soldiers experiencing emotional or social problems.



- Referring soldiers to specific mental health officers, physicians, or agencies when indicated.

- Assisting with group debriefings, counseling and therapy sessions, and leading group discussions.

- Providing individual case consultation to commanders, NCOs, chaplains, battalion surgeons, and physician assistants within the supported brigade.

- Collecting information from units regarding unit cohesion and morale which include—

- Obtaining data on disciplinary actions.

- Collecting information with questionnaires.

- Conducting structured interviews.

- Collecting information on individual BF soldier cases pertaining to—

- Prior effectiveness of the soldier.

- Precipitating factors causing BF.

- Potential for RTD

When the supported units are tactically deployed, the behavioral science NCOs use the clearing stations operated by the ASMCs as the centers of their operations, but the NCOs are mobile throughout the AO. Their priority functions are to prevent unnecessary evacuations and to coordinate RTD, not to treat cases. Through the ASMC commanders, they keep abreast of the

tactical situation and plan and project requirements for CSC support when units are pulled back for rest and recuperation.

*(5) Behavioral science specialist.*

There are three behavioral science specialists (E-4 and E-3, MOS 91 G10). These specialists assist mental health officers and NCOs in gathering social and psychological data to support patient evaluation. They provide initial screening of patients suffering emotional disorders. In addition to their duties, they operate and maintain assigned vehicles. Under the supervision of a mental health officer or an NCO, their specific duties include—

- Providing supportive counseling for patients experiencing emotional or social problems.

- Assisting in the evaluation of the emotionally disturbed or mentally ill.

- Assessing a patient's mental status (level of functioning capacity) and his need for professional services.

- Deploying to an ASMC to assist an NCO CSC coordinator or mental health officer.

- Serving as squad leader for up to 12 junior enlisted grade BF soldiers in a restoration program.

**2-4. Mental Health Personnel in the Separate Brigades**

In the separate brigades, both light and heavy, mental health personnel are assigned to the medical company, separate brigade. In the light separate brigade, one behavioral science NCO is assigned to the medical company clearing section. He functions as a brigade CSC

coordinator and advises the commander on mental health/CSC issues. In the heavy separate brigade, the medical company has a mental health section which consist of a behavioral science NCO and two behavioral science specialists. The NCO's duties are also consistent with those

identified for the brigade CSC coordinator. When a separate brigade is attached to a division, the mental health personnel assigned to that brigade work with and come under the technical supervision of the division mental health section.

## Section II. COMBAT STRESS CONTROL COMPANY

### 2-5. Medical Company, Combat Stress Control (TOE 08-467L000)

The medical company, CSC is employed in the COMMZ and the CZ. In the corps areas, it sends teams forward, as required, to reinforce CSC elements operating in the divisions. The medical companies, CSC and medical detachments, CSC (TOE 08-567 LA00) are replacing the medical detachments, psychiatric (OM Teams), which are under the H-series TOE.

a. *Mission.* A medical company, CSC (Figure 2-3) provides comprehensive CSC support for two or more divisions and their corps slices (combat, CS, and CSS units). This comprehensive support involves all six CSC functions that were discussed in Chapter 1 to a varying degree based on the threat and tactical operations support requirements.

b. *Basis of Allocation.* The basis of allocation for the medical company, CSC is 0.4 unit per division supported. One medical company, CSC will normally support two divisions and their corps slice in a high-intensity conflict. In a mid-intensity conflict, because of the reduced likelihood of BF casualties, a medical company, CSC may be able to support up to five divisions. The medical company, CSC is supplemented by allocation of a variable number of CSC medical detachments. The basis of allocation for CSC medical detachments is one unit per division, and one unit per two or three separate brigades or

regiments in the corps. The medical detachment, CSC will be discussed in Section III of this chapter.

c. *Assignment.* The medical company, CSC may be assigned to a medical command (MEDCOM), medical brigade or medical group. It may be further attached to an ASMB. For a listing of major items of equipment assigned, see Appendix A.

d. *Organization.* The medical company, CSC is organized into a headquarters section, a preventive section, and a restoration section. The company is dependent on appropriate elements of the MEDCOM, medical brigade, or medical group for administrative and medical logistical support, medical regulating, BF casualty delivery, and medical evacuation. The company is dependent on appropriate elements of the corps or COMMZ for finance, legal, personnel and administrative services, food service, supply and field services, supplemental transportation, and local security support services. When conducting a large restoration or reconditioning program, the medical company, CSC is dependent on the medical-holding company for attachment of a medical-holding platoon to support the program. When medical company, CSC elements or teams are deployed to division areas, they are dependent on the division medical companies (such as the MSB medical company or the forward support battalion [FSB] medical company) for patient accounting, transportation, food service, and field service support.

e. *Employment in the Theater.* The medical company, CSC operates in the corps area and deploys its assets forward, as required, in support of operations for supported divisions and separate brigades. In the corps area, it provides CSC support on an area basis and conducts CSC consultation, restoration, and reconditioning programs. The medical company, CSC normally operates from the medical brigade or group headquarters. The medical company,

CSC may be attached to ASMBs, combat support hospitals (CSHs), or other corps medical units. The task-organized CSC element is also deployed into the supported division areas, as required, to augment the medical detachment, CSC and organic division mental health section/CSC personnel. The medical company, CSC provides advice and assistance to its higher headquarters on combat stress and NP issues.

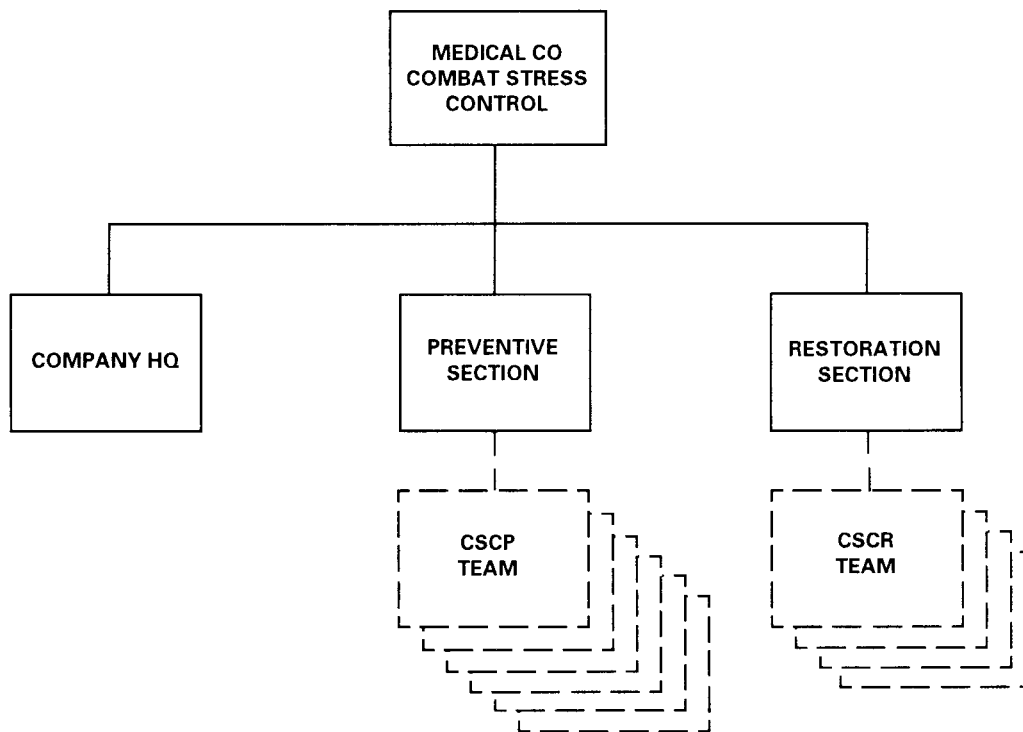

**MISSION:** PROVIDE COMBAT STRESS CASUALTY PREVENTION, TREATMENT AND MANAGEMENT ON AN AREA BASIS THROUGHOUT THE COMBAT ZONE.

**EMPLOYMENT:** COMMZ AND CORPS

**BASIS OF ALLOCATION:** ONE PER TWO DIVISIONS

Figure 2-3. Medical company, combat stress control (modular) teams.

## 2-6. Headquarters Section

The headquarters section provides command and control (C2) and unit-level administrative and maintenance support to its subordinate sections when they are collocated with the company. The headquarters section may also provide assistance to detached elements by making site visits if the elements are within a feasible distance for ground transportation. The medical company, CSC elements normally deploy with limited maintenance and are without administrative support. When these CSC elements deploy, they are dependent on the supported units for patient accounting, transportation, food service, and field services. The personnel assigned to the headquarters section include—

- Company commander.
- Chaplain.
- Medical operations officer.
- First sergeant.
- Supply sergeant.
- Nuclear, biological, and chemical NCO.
- Unit clerk.
- Commander's driver/behavioral science NCO.
- Prescribed load list (PLL) clerk.
- Armorer.
- Motor sergeant.
- Light-wheeled vehicle mechanic (two).

- Power generation equipment repairman.
- Cook (three).

Personnel from the headquarters section are deployed with teams or task-organized CSC elements as required.

a. *Company Commander.* The medical company, CSC commander (Lieutenant Colonel [LTC], MC, AOC 60W00) plans, directs, and supervises the operations of the company. The commander is also responsible for the training, discipline, billeting, and security of the company. He provides daily reports to his higher headquarters as established by the tactical standing operating procedures (TSOPs) and corps reporting procedures. He serves as the NP consultant on the staff of the medical group. As a psychiatrist, he coordinates with command and unit physicians regarding care and disposition of BF casualties and NP patients. He exercises clinical supervision over all treatment provided by the CSC sections and detachments. He performs physical and mental status evaluations in emergency or command evaluation situations; this includes diagnosing, prescribing initial treatment, and determining disposition. The commander interfaces with higher and supported headquarters and with supported CSC medical detachments, ASMB mental health sections, and division mental health sections. He keeps informed on CSC operations through daily reports and by frequent visits to task-organized CSC elements deployed from his company.

b. *Chaplain.* The chaplain (CPT, Chaplain [CH], AOC 56A00) provides religious/ethical education and perspective to the dispersed sections for the prevention and treatment of BF and misconduct stress behaviors. He interfaces CSC activities with unit ministry teams in maneuver units, hospital chaplains, and with staff chaplains at each headquarters level. The

chaplain usually accompanies the medical company, CSC commander when he visits supported units and task-organized CSC elements deployed in support of those units. The chaplain has a chaplain's kit to conduct services but is without a chaplain's assistant. The chaplain's primary role is to aid CSC personnel in preventive stress control and in working with BF casualties and misconduct stress behaviors. In addition to his coordination, liaison, and training duties, he provides religious support to BF casualties and to staff as available time and support requirements permit.

*Medical Operations Officer.* The medical operations officer (CPT, MS, AOC 70B67) is the principal assistant to the company commander on all matters pertaining to the tactical employment of company assets. He is responsible for overseeing operations and administrative, supply, and maintenance activities within the company. His responsibilities also include—

- Coordinating administrative activities with the staff of the higher medical headquarters.
- Ensuring unit operations and communications security.
- Keeping the commander current on the corps' and supported divisions' tactical situations.
- Assisting the commander with development of CSC support estimates and plans.
- Training.
- Coordinating movement orders and logistical support for deployed company elements.

*d. First Sergeant.* The first sergeant (E8, MOS 91B50) serves as the principal enlisted assistant to the company commander. He

manages the administrative activities of the company command post (CP). He supervises the company activities of the unit clerk and maintains liaison between the commander and assigned NCOs. He provides guidance to enlisted members of the company and represents them to the commander. He plans, coordinates, supervises, and participates in activities pertaining to organization, training, and combat operations for the company. He assists the company commander in the performance of his duties. The first sergeant also assists the medical operations officer and performs the duties of an operations NCO.

*e. Supply Sergeant.* The supply sergeant (E6, MOS 76Y30) requests, receives, stores, safeguards, and issues general supplies and salvages equipment authorized to the company. He maintains the company supply records, supervises unit supply operations, and maintains accountability for all equipment organic to the company.

*f. Nuclear, Biological, and Chemical Noncommissioned Officer.* The NBC NCO (E5, MOS 54B20) coordinates NBC defense operations for the company. He supervises training pertaining to procedures and techniques of NBC defense. He predicts the effects of weather and terrain on chemical operations. His responsibilities also include preparing predictions on nuclear fallout and on nuclear, chemical, and biological downwind hazards. He prepares and evaluates NBC reports and computes expected radiation effects affecting personnel, equipment, and operations. This NCO is the technical advisor to the unit commander on matters pertaining to NBC functions. He provides expertise and training in the operations and maintenance of NBC equipment and supervises decontamination of unit equipment, supplies, and personnel (not patients). At time of heavy caseloads (unless the unit is in an active NBC environment), he serves as squad leader for up to ten BF casualties in reconditioning or restoration.

g. *Unit Clerk.* The unit clerk (E4, MOS 75B10) provides and coordinates personnel and administrative support to company personnel and maintains unit administrative records. He also advises on and coordinates personnel actions for recovering BF casualties or RTD soldiers that require other administrative actions.

h. *Commander's Driver/Behavioral Science Noncommissioned Officer.* The commander's driver/behavioral science NCO (E5, MOS 91G20) assists the commander and chaplain as a vehicle driver. He performs surveys and collects information on stress and stressors in units which the commander visits. He also checks the status of recovered stress casualties.

i. *Prescribed Load List Clerk.* The logistic automation specialist (PLL clerk [E5, MOS 92A20]) also serves as the maintenance shop clerk. He performs duties involving supply of repair parts and maintenance of equipment records. He initiates and maintains records on equipment use, operations, history, maintenance, modifications and calibration. He is responsible for requesting, receiving, recording, and storing parts and tools. In addition, he issues such parts to motor vehicle and power generation repair personnel as required. He is also responsible for—

- Providing input for the materiel readiness report.
- Assisting in the scheduling of maintenance and repair services.
- Issuing tools to motor vehicle and power generation repair personnel, as required.

j. *Armorer.* The supply specialist/armorer (E4, MOS 92Y10) maintains the weapons storage area, issues and receives munitions, and performs small arms unit maintenance. He

assists with general supply activities and operates the vehicle assigned to the supply element.

k. *Motor Sergeant.* The motor sergeant, a senior vehicle mechanic (E-6, MOS 63 B30), supervises and performs maintenance on unit vehicles. He advises, trains, and supervises other maintenance personnel assigned to the company. His responsibilities also include—

- Preparing daily work sheets and charts.
- Supervising scheduled maintenance and repair services.
- Implementing the Army Oil Analysis Program.
- Recommending maintenance procedures.
- Supervising and performing vehicle recovery operations.
- Ensuring that company equipment meets calibration times and services.

l. *Light-Wheeled Vehicle Mechanic.* There are two light-wheeled vehicle mechanics (one E-5, MOS 63B20 and one E-3, MOS 63B10) who perform organizational maintenance and work under the supervision of the motor sergeant. They perform organizational preventive maintenance and repairs on gasoline and diesel-fueled, light-wheeled vehicles. Light-wheeled vehicles include prime movers designated as 5 tons or less and their trailers and associated items. Duties of the light-wheeled vehicle mechanics include—

- Diagnosing malfunctions of light-wheeled vehicles and associated items.
- Troubleshooting engine/equipment problems using technical manuals (TMs).

test and diagnostic measurement equipment (TMDE), and other equipment as required.

- Applying applicable safety precautions.
- Performing scheduled maintenance and repairs on vehicles and equipment assisted by the vehicle operator.
- Maintaining and accounting for tools and equipment issued to him.
- Deploying with company element (task-organized CSC element) to provide maintenance for company or attached vehicles. When deployed, they work with the maintenance section/element of the unit to which the task-organized CSC element is attached.

*m. Power Generation Equipment Repairman.* The power generation equipment repairman (E4, MOS 52D10) performs unit maintenance functions. The major functions and tasks of the repairman include—

- Applying applicable safety precautions.
- Inspecting equipment, determining category of maintenance and extent of repairs, and recording results.
- Classifying unserviceable components and assemblages as required.
- Performing preventive maintenance checks and services (PMCS) on shop equipment.
- Maintaining and accounting for tools issued.
- Training unit personnel on how to properly operate and perform user maintenance on assigned generators.

*n. Cooks.* Three cooks (two E4 and one E3, MOS 94B10) provide food service (tray-pack heating) for the company when it is assembled. More often, they are deployed with a task-organized CSC element and further attached for work with the food service section of the supported medical unit. They also train CSC personnel on food tasks which may be used as a part of their CSC restoration or reconditioning program. They serve as work group leaders for BF casualties performing food service tasks as part of the BF casualty's treatment.

## 2-7. Preventive Section

This section has 6 psychiatrists, 6 social work officers, and 12 behavioral science specialists assigned to the section. This section can divide into six 4-person combat stress preventive teams. Elements of the section may also be task-organized with elements of the restoration section to form task-organized CSC elements for deployment to conduct CSC operations. The company commander will appoint the combat stress preventive team or task-organized CSC element leaders, considering rank, professional qualifications, and especially experience. The preventive section's responsibilities include—

- Providing preventive consultation.
- Assisting units with REST category BF cases and RTD of recovered BF casualties.
- Providing NP triage and stabilization as required.
- Supervising restoration of category HOLD BF casualties by medical personnel.
- Providing medical, psychiatric, and social work expertise to restoration and reconditioning programs.

- Deploying combat stress preventive teams to reinforce CSC elements operating in the divisions and corps areas.

- Providing reconstitution mental health support to physically and mentally exhausted units.

a. *Psychiatrist.* The six psychiatrists (MAJ [three], CPT [three], MC, AOC 60W00) assigned to this section examine patients and provide consultation. They make neuropsychological and medical diagnosis and prescribe and provide treatment. They also direct disposition of patients. The senior psychiatrist performs the duties of section leader and directs the activities of the section when the section is assembled. Psychiatrists assigned to this section may be deployed in support of CSC operations with the section, or as members of either a combat stress preventive team or a task-organized CSC elements. When deployed as a member of a combat stress preventive team or a task-organized CSC element, the psychiatrist's duties include—

- Establishing and providing CSC support.

- Providing staff consultation to supported units as required. This includes nuclear surety, security clearances, and alcohol and drug abuse preventive program.

- Being responsible for the diagnosis, treatment, rehabilitation, and disposition of NP and problematic BF cases.

- Participating in the diagnosis and treatment of the wounded, ill, and injured, especially of those who can RTD quickly.

- Consulting and providing training to unit leaders and medical personnel regarding identification and management of NP disorders, BF, and misconduct stress behaviors.

- Providing therapy or referral for soldiers with NP disorders.

- Providing supervision and training of assigned and attached mental health personnel.

- Conducting and supervising unit survey interviews and critical event debriefings.

b. *Social Work Officer.* Six social work officers (MAJ [two], CPT [four], MS, AOC 73A67) are assigned to this section. They provide proactive consultation, give individual and group counseling, supervise restoration/reconditioning, and coordinate RTD of recovered cases. They also provide staff advice and coordinate Army and civilian social services support. These social work officers may be divided among several task-organized CSC elements or be utilized as a member of a combat stress preventive team. When deployed as a member of a combat stress preventive team or task-organized CSC element, the social work officer's duties include—

- Evaluating psychosocial (unit and family) functioning of soldiers with BF and misconduct stress behavior.

- Coordinating and ensuring the return of recovered BF and NP soldiers to duty and their reintegration into their original or new unit.

- Identifying and resolving organizational and social environmental factors which interfere with combat readiness.

- Coordinating support for soldiers and their families through Army and civilian community support agencies, when possible.

- Apprising unit leaders, primary care physicians, and others health care providers of available social service resources.



- Providing consultation to supported unit commanders and to other mental health/CSC personnel regarding problem cases.

- Counseling and providing therapy or referral for soldiers with psychological problems.

- Conducting and supervising unit survey interviews and critical event debriefings.

*c. Preventive Section Sergeant.* The senior behavioral science NCO (E-7, MOS 91G40) is the preventive section sergeant. This senior NCO provides management assistance to the mental health officers for both the technical and tactical operations of the section. He supervises subordinate members. His specific duties include—

- Keeping the section leader informed.

- Monitoring, facilitating, and supervising the training activities of the section.

- Monitoring and coordinating situation reports from deployed task-organized CSC elements or combat stress preventive teams.

- Conducting classes on selected mental health topics for senior NCOs of supported units.

- Conducting and supervising unit survey interviews and critical event debriefings.

*d. Behavioral Science Noncommissioned Officer.* There are five behavioral science NCOs (two E-6, MOS 91G30 and three E-5, MOS 91G20). The two NCOs (E-6) act as assistant section sergeant and assist the section sergeant with his duties. The NCOs collect and record social and psychological data and counsel

personnel with personal, behavioral, or psychological problems. They assist with the management of the preventive section. The NCOs also deploy as NCOICs of combat stress preventive teams, or as members of task-organized CSC elements. Their general duties include—

- Assisting in a wide range of psychological and social services.

- Compiling caseload data and referring patients to specific mental health officers and physicians in supporting MTFs.

- Providing counseling to soldiers experiencing emotional or social problems.

- Assisting with group counseling and debriefing sessions and leading group discussions.

- Collecting data in unit survey interviews pertaining to unit cohesion, morale, and individual mental readiness for combat.

- Assisting in critical event debriefings.

*e. Behavioral Science Specialist.* There are six behavioral science specialists (three E-4 and three E-3, MOS 91G20) assigned to the section. These specialists assist the mental health officer and NCOs in gathering social and psychological data to support patient evaluations. Under the supervision of the mental health officer and NCOs, they provide initial screening of patients suffering emotional or social problems. In addition to their duties, they operate and maintain assigned vehicles. Under the supervision of the mental health officer, their specific duties include—

- Serving as team leaders and providing supportive counseling to BF casualties and misconduct stress behaviors cases experiencing emotional or social problems.

- Assisting in the evaluation of BF casualties and misconduct stress behaviors.
- Assessing the mental status of BF casualties and misconduct stress behaviors (level of functioning capacity) and their need for professional services.
- Collecting data in unit survey interviews.
- Assisting in critical event debriefings.

## 2-8. Restoration Section

The restoration section consists of 4 psychiatric nurses, 4 clinical psychologists, 4 occupational therapy (OT) officers and 4 patient administration specialists. It also has 1 senior psychiatric wardmaster, 7 psychiatric specialists, 8 OT specialists, and 12 behavioral science specialists. This section can divide into four combat stress restoration teams. Elements of this section are usually task-organized with elements of the preventive section to form task-organized CSC elements which operate restoration or reconditioning centers. At these centers, they provide NP triage, diagnosis, stabilization, treatment, and disposition. Section personnel, as members of task-organized CSC elements or combat stress restoration teams, also deploy routinely to provide preventive consultation and reconstitution support to units in the corps area. They reinforce and may reconstitute medical detachment, CSC teams in the division support areas.

### NOTE

The priority role for all CSC personnel is the prevention of BF and other stress-related casualties. This is as true for the restoration section as it is for the preventive section.

The section leader position may be held by any of the officers assigned to the section. The company commander will appoint the section leader based on rank, professional qualifications, and especially experience. This same rationale is used in selecting leaders for the task-organized CSC elements and combat stress restoration teams.

a. *Occupational Therapy Officer.* Four OT officers (MAJ [two], CPT [two], Army Medical Specialist Corps [SP], AOC 65A00) are assigned to the section. They serve as environmental managers using daily living task, physical reconditioning, work, and other activities to counteract combat stress reactions. Preventive treatment programs include individual work assignments, organized group work projects, common soldier task review, stress management education, recreation, and physical reconditioning. Their responsibilities include—

- Providing command consultation to leaders regarding work schedules and restorative off-duty activity programs.
- Performing functional occupational evaluations of BF casualties.
- Performing neuromuscular evaluations, especially upper extremities and hands.
- Assigning BF casualties to physical reconditioning and work groups.
- Overseeing physical reconditioning and work programs for BF casualties.
- Selecting appropriate activities based on a BF casualty's assessment.
- Evaluating functional work capacity.
- Modifying reconditioning programs as required.

- Maintaining records of therapy/treatment.

- Reporting status of BF casualties to psychiatrists and staff members on a daily basis, or in accordance with the TSOPs.

- Conducting unit survey interviews and critical event debriefings.

*b. Psychiatric/Mental Health Nurse.* The section consist of four psychiatric/mental health nurses (MAJ [two], CPT [two], Army Nurse Corps [AN], AOC 66C00). The two majors positions should be filled by clinical nurse specialists (AOC 66C7T). The psychiatric nurses provide specialized care, as required, for all BF, misconduct stress behaviors and NP casualties, especially those with severe behavioral disturbances and/or concurrent physical illness or injury. They administer medications according to the psychiatrist/physician's orders. The clinical nurse specialist (AOC 66 C7T), when properly trained, prescribes medications under the supervision of a psychiatrist/physician. In coordination with the psychiatrist, clinical psychologist, occupational therapist, and other section members, the psychiatric nurses responsibilities include—

- Conducting individual and group therapy and stress control education sessions.

- Providing preventive and command consultation, especially to medical units.

- Assisting with the development of the RTD plan for each case.

- Ensuring the BF casualty's therapeutic program, as outlined in the RTD plan, is followed.

- Monitoring the BF casualty's status and record pertinent case data.

- Conducting nursing reports in accordance with TSOPs to update section members.

- Conducting and supervising unit survey interviews and critical event debriefings.

*c. Clinical Psychologist.* There are four clinical psychologists (MAJ [one], CPT [three], MS, AOC 73B67) assigned to the section. Their duties include—

- Providing diagnostic expertise for triage.

- Conducting psychological and neuropsychological testing.

- Providing behavioral treatment and counseling.

- Conducting and supervising surveys of unit cohesion, morale, and individual mental readiness for combat.

- Providing command consultation.

- Supervising subordinate personnel.

- Conducting and supervising critical event debriefings.

*d. Senior Behavioral Science Noncommissioned Officer.* The senior behavioral science NCO (E-7, MOS 91G40) assists the section leader and the clinical psychologist with the accomplishment of their duties. He provides assistance to the mental health officers with their administrative and clinical duties. He supervises the behavioral science specialists working with the clinical element of the section. He assists with the management and operations of the clinical

element of the section. He provides assistance with the management of operations (technical and tactical ) of the section. His specific duties include—

- Keeping the section leader informed.
- Monitoring, facilitating, and supervising the training activities of subordinates in the clinical element.
- Monitoring and coordinating situation reports from deployed task-organized CSC elements or combat stress preventive teams.
- Conducting classes on selected mental health topics for senior NCOs of supported units.
- Conducting and supervising unit survey interviews and critical event debriefings.

*e. Senior Psychiatric Wardmaster.*

The psychiatric wardmaster (E7, MOS 91F40) assists the section leader with administrative and clinical duties and supervises the restoration or reconditioning center operations. He provides direct supervision for the seven psychiatric specialists (MOS91F) and three patient administration specialists (MOS71G) (ward clerks). If the restoration and reconditioning centers' operations are centrally located, he assists with the overall management of their operations. If the section divides into two or more task-organized CSC elements, he manages the restoration and reconditioning center that is most likely to have the greatest need. His responsibilities include assisting with planning and executing the establishment, disestablishment, movement, and operations of the restoration and reconditioning centers. He is responsible for assisting the psychiatric nurses with BF casualty care activities. He also assists the section leader with the

management and operations (technical and tactical) of the section, His specific duties include—

- Keeping the section leader informed.
- Monitoring, facilitating, and supervising the training activities of assigned personnel.
- Monitoring and coordinating situation reports from deployed restoration and reconditioning centers, either with task-organized CSC elements or combat stress preventive teams.

*f. Psychiatric Noncommissioned Officer.*

Two psychiatric NCOs (E-6, MOS 91F30, and E-5, MOS 91F20) are assigned to the section. They manage and provide supervision for the BF casualty's care. They deploy with either combat stress restoration teams or task-organized CSC elements. They function as BF casualty care managers for the restoration and reconditioning centers. They assist the psychiatric nurse(s) with—

- Planning and executing the establishment, disestablishment, and movement of the restoration or reconditioning center.
- Conducting restoration and reconditioning center operations.
- Providing guidance and training to subordinate psychiatric specialists and other BF casualty care providers.
- Administering medications.

As squad leaders, they provide direct supervision for BF casualties and monitor their progress. They also assist with unit survey interviews and critical event debriefings.

*g. Psychiatric Specialist.* Five psychiatric specialists (three E-4 and two E-3, MOS

91F20) provide BF casualty care and intervention, as required. These specialists deploy with either the combat stress restoration teams or task-organized CSC elements. Their duties include—

- Following the RTD plans for cases placed under their supervision.
- Coordinating with the psychiatric nurse and other staff members on questions pertaining to the RTD plan.
- Providing direct supervision for BF casualties (as squad leaders) and monitoring their progress.
- Recording and reporting to the psychiatric nurses and other mental health staff members on the status and any other pertinent observation of cases assigned to them.
- Assisting with unit survey interviews and critical event debriefings.
- Operating and maintaining assigned vehicles.

h. *Behavioral Science Noncommissioned Officer.* Five behavioral science NCO (two E-6, MOS 91G30, and three E-5, MOS 91G20) are assigned to the section. Their responsibilities include—

- Collecting and recording social and psychological data.
- Counseling soldiers with personal, behavioral, or psychological problems.
- Assisting with the management of the section.
- Deploying as members of combat stress preventive team or task-organized CSC elements.

Their general duties include—

- Assisting in a wide range of psychological and social services.
- Assisting with initial screening and assessment of new cases.
- Compiling caseload data and referring BF casualties to specific mental health officers and psychiatrists.
- Providing counseling to BF casualties experiencing emotional or social problems.
- Assisting the psychologist with administration of psychological testing.
- Assisting with group counseling and therapy sessions and leading group discussions.
- Assisting with unit survey interviews and critical event debriefings.

i. *Behavioral Science Specialist.* Six behavioral science specialists (three E-4 and three E-3, MOS 91G20) are assigned to the section. Their duties are consistent with those previously identified above (2-7e ).

j. *Occupational Therapy Noncommissioned Officer.* Three OT NCOs (one E-6, MOS 91L30, and two E-5, MOS 91L20) are assigned to the section. They assist the occupational therapists with—

- Evaluating functional capacity and supervising physical reconditioning programs.
- Coordinating and setting up work programs with supported and supporting units and overseeing work programs.

- Supervising and ensuring appropriate training for subordinate OT specialists and other mental health personnel.
- Providing BF casualty status updates to the occupational therapists and other staff members as required.
- Providing direct supervision of BF casualties and squad leaders.
- Assisting with unit survey interview and critical event debriefings.

The OT NCOs deploy with either combat stress restoration teams or task-organized CSC elements.

*k. Occupational Therapy Specialist. Five* OT specialists (two E-4 and three E-3, MOS91L20) work under the supervision of the occupational therapists and OT NCOs. Their duties include—

- Assisting the occupational therapists with evaluating functional capacity.
- Assisting with the supervision of work programs.
- Assisting with the identification of useful work projects.
- Assisting with organizing activities which facilitate the recovery of the BF casualties.
- Serving as team leader for up to 12 BF casualties.
- Assisting with unit survey interviews and critical event debriefings.

These OT specialists deploy with combat stress restoration teams or task-organized CSC elements.

*l. Patient Administration Noncommissioned Officer.* The patient administration NCO(E-5, MOS 71G) is responsible for managing

patient statistics of all BF casualties seen by the company element. He is normally located with the company headquarters but makes visits to task-organized CSC elements as required to ensure company elements are complying with patient administrative requirements. He is responsible for forwarding the Medical Summary Report (RCS Med-302 [R3]) in accordance with AR 40-400, and ensures that all BF casualty accountability and status reports are forwarded as directed by higher headquarters. He initiates the field medical card (FMC) (DD Form 1380) on all BF casualties seen for consultation and medical treatment and those placed in the center for restoration or reconditioning programs. He ensures that all restoration and reconditioning centers maintain the Daily Disposition Log. He supervises subordinate patient administrative specialists. He coordinates transportation and evacuation, as required, for BF casualties sent rearward for additional restoration or reconditioning and for recovered BF casualties returning to their units.

*m. Patient Administration Specialists.*

The patient administration specialists (two E-4 and one E-3, MOS71G20) participate in the in-processing of BF casualties into restoration and reconditioning centers. They are responsible for initiating reports and forms identified in the preceding paragraph. They maintain the Daily Disposition Log. When deployed with a combat stress restoration team or task-organized CSC elements, they work with the patient administration section of the medical unit to which the task-organized CSC element or combat stress restoration team is attached. Through the patient administration section of the unit they are attached to, they coordinate BF casualty evacuation and transportation requirements. They maintain assigned vehicles and operate company radios. They coordinate the disposition of BF casualties through supporting unit communications assets. Patient administration specialists deploy with combat stress restoration teams or task-organized CSC elements.

### Section III. COMBAT STRESS CONTROL DETACHMENT

#### 2-9. Medical Detachment, Combat Stress Control (TOE 08-567LA00)

The medical detachment, CSC (Figure 2-4) is a 23-person unit composed of a headquarters, a combat stress preventive section, and combat stress restoration teams. The modular CSC teams found in the medical detachment, CSC are similar to those found in the CSC medical company. The medical detachment, CSC provides CSC planning, consultation, training, and staff advice to C2 headquarters and the units to which they are assigned regarding—

- Combat and noncombat stressors affecting the troops.
- Mental readiness.
- Morale and cohesion.
- Potential for BF casualties.

The detachment provides NP triage, basic stabilization, and restoration for BF casualties. Under some circumstances, it may provide reconditioning for NP and alcohol and drug abuse patients. This unit is dependent on support from appropriate elements of the corps to include—

- Religious.
- Finance.
- Legal.
- Personnel and administrative.
- Food service.
- Supply and field services.

- Local security support.
- Unit maintenance services.

The detachment is dependent on units to which attached for support to include—

- Medical administration.
- Logistical, including health services logistics.
- Medical regulating of patients.
- Battle fatigue casualty evacuation.
- Coordination for RTD of recovered BF soldiers.

Personnel resources to guard enemy prisoner of war (EPW) patients provided by the echelon commander.

- Food service.
- Supply and field services.
- Local security support.
- Unit maintenance services.

a. *Mission.* The medical detachment, CSC provides comprehensive CSC support to a division, or to two or three separate brigades or regiments. As the tactical situation permits, this detachment can provide all six of the CSC functions identified, but reconditioning is unlikely when it is deployed forward of the corps. For a listing of major items of equipment assigned, see Appendix A.

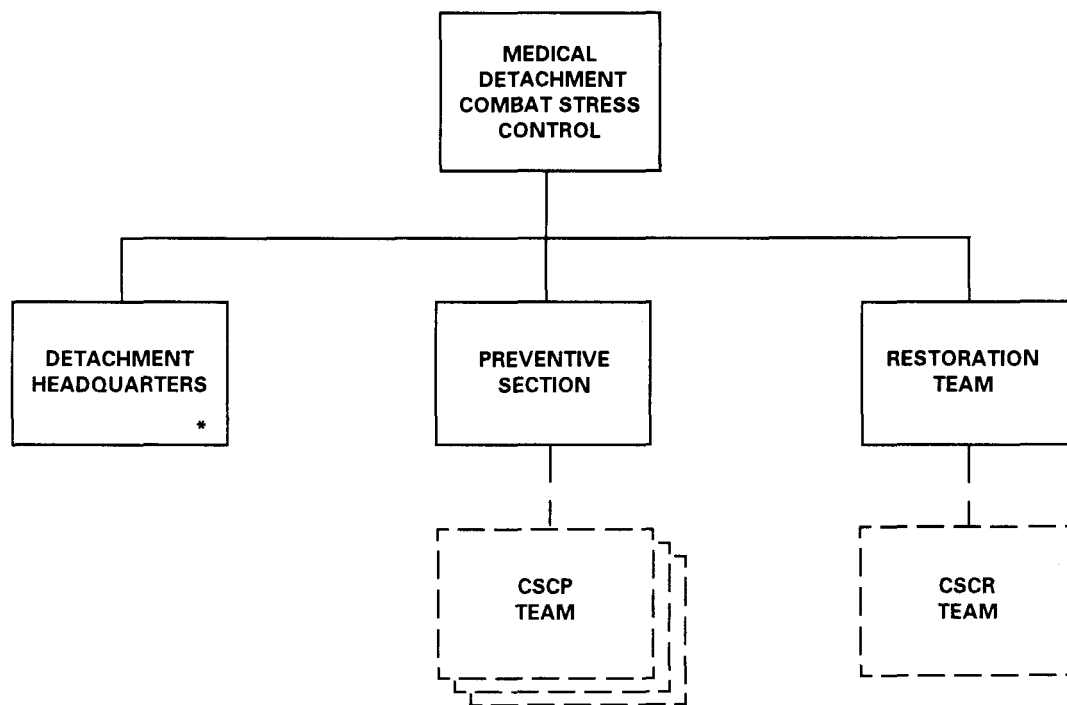

**MISSION:** PROVIDE FORWARD COMBAT STRESS CASUALTY PREVENTION, RESTORATION, AND MANAGEMENT SUPPORT.

**EMPLOYMENT:** CORPS AND DIVISION.

**BASIS OF ALLOCATION:** TO THE CORPS ON BASIS OF ONE PER DIVISION AND ONE PER TWO TO THREE SEPARATE BRIGADES.

\* DETACHMENT COMMANDER DEPLOYS FORWARD AS PSYCHIATRIST IN ONE CSCP TEAM IF NEEDED. THE SENIOR NCO IN THE CSCR TEAM IS THE DETACHMENT NCOIC.

*Figure 2-4. Medical detachment, combat stress control (modular) teams.*



*b. Assignment.* The medical detachment, CSC is normally assigned to a corps medical brigade with further attachment to a medical group, medical company, CSC, ASMB, or to a DISCOM of a supported division.

## 2-10. Detachment Headquarters

The detachment headquarters provides C2 for the detachment. The headquarters section is responsible for planning, coordinating, and implementing CSC support for supported units. The headquarters has two personnel assigned: the detachment commander and the detachment NCOIC. The detachment commander also serves as a treating physician with the preventive section. The detachment NCOIC (a senior behavioral science NCO) also serves as the restoration team sergeant. Detachment officers and NCOs from the preventive team and the restoration team may be assigned additional duties which enhance the overall effectiveness of the headquarters section. Additional duty responsibilities may include—

- Maintenance.
- Training.
- Security, plans, and operations.
- Nuclear, biological, and chemical defense officer/NCO.
- supply.

These duties may be rotated to achieve maximum cross-training.

*a. Detachment Commander.* The detachment commander, a psychiatrist (MAJ, MC, AOC 60W00), performs normal C2 and supervisory functions as well as serving as a treating physician in one of the combat stress preventive

teams. He coordinates with the command surgeon and mental health sections regarding care and disposition of patients. He exercises clinical supervision over treatment in all the CSC teams. He provides NP expertise to supported unit headquarters. In conjunction with supported unit headquarters and MTFs, the detachment commander plans CSC support for the unit's operations. He deploys the detachment's teams separately, or task organizes personnel across teams as needed to form task-organized CSC elements. He appoints team leaders based on best qualifications by experience as well as by AOCs.

*b. Detachment Noncommissioned Officer In Charge.* The detachment NCOIC (E-7, MOS 91G) assists the detachment commander in the accomplishment of his duties. He performs administrative duties; he receives and consolidates reports from deployed detachment elements and forwards them to higher headquarters. The detachment NCOIC coordinates support for the detachment and for detachment elements deployed to supported units. He represents the commander at staff meetings and on-site visits to the CSC teams when the commander is occupied with clinical duties. When the detachment is divided into combat stress preventive and combat stress restoration teams or task-organized CSC elements, the NCOIC normally locates with the combat stress restoration team. The combat stress restoration team is usually the largest and rear-most of the medical detachment, CSC elements. It is usually located closest to the supported unit headquarters and coordinating staff (DMOC and MSB headquarters).

## 2-11. Preventive Section

This section has three psychiatrists, three social work officers, and six behavioral science specialists assigned to the section. This section can divide into three 4-person combat stress preventive teams. Combat stress control preventive

team leaders are selected by the detachment commander based on experience as well as on grade and specialty. Elements of the section may also be task-organized with elements of the restoration team to form task-organized CSC elements for special CSC operations. The preventive section's responsibilities include—

- Providing preventive consultation support to leaders, chaplains, and medical personnel located in and around the brigade support area.
- Assisting nonmedical units with REST category BF casualties and the RTD of recovered BF soldiers.
- Providing NP triage and stabilization.
- Supervising restoration of HOLD category BF casualties by medical personnel and providing restoration for selected cases.
- Providing medical, psychiatric, and social work expertise to restoration programs staffed by medical detachment, CSC restoration team.
- Deploying to units to provide reconstitution support.

*a. Psychiatrist.* The three psychiatrists (MAJ [also the detachment commander], CPT [two], MC, AOC 60W00) are assigned to this section. The senior psychiatrist/detachment commander directs the activities of the section. Psychiatrists assigned to this section are usually deployed in support of CSC operations as members of a combat stress preventive team, but may remain with the combat stress restoration team under some circumstances. These psychiatrists will usually associate closely with the supported FSMC's area support treatment team. They

coordinate CSC operations, as required, and perform those duties previously identified above paragraph 2-7 a).

*b. Social Work Officer.* Three social work officers (MAJ [one], CPT [two], MS, AOC 73A67) are assigned to this section. These social work officers usually deploy as members of the combat stress preventive teams, but could remain with the combat stress restoration team based on mission requirements. As a member of a combat stress preventive team or other CSC element, in addition to those duties identified above (paragraph 2-7 b), the social work officer's duties include—

- Evaluating soldiers with BF and misconduct stress behavior.
- Supervising subordinate personnel.

*c. Preventive Section Sergeant.* The senior behavioral science NCO (E-6, MOS 91G30) is the preventive section sergeant. His duties are the same as those previously identified above (paragraph 2-7 c).

*d. Behavioral Science Noncommissioned Officer.* There are two behavioral science NCOs (E-5, MOS 91 G20). These two NCOs act as assistant section sergeant and assist the section sergeant with his duties. Their duties are consistent with those identified above (paragraph 2-7 d). They deploy as NCOICs of teams and may be assigned as the team leader for up to 14 BF casualties in a restoration center.

*e. Behavioral Science Specialist.* There are three behavioral science specialists (two E-4 and one E-3, MOS 91G20) assigned to the section. These specialists perform those duties previously identified above (paragraph 2-7 e). In addition to their duties, they operate and maintain assigned vehicles.

## 2-12. Restoration Team

The restoration team provides staff and equipment for operating a restoration or (rarely) reconditioning center. The center provides NP triage, stabilization, treatment, and disposition. The team, or its members, deploy as necessary to provide consultation and reconstitution support to units. The combat stress restoration team leader's AOC is immaterial; any of the officers assigned to the section may be appointed as the team leader by the unit commander. The commander will base his selection on experience as well as specialty and grade.

*a. Occupational Therapy Officer.* The OT officer (CPT, SP, AOC 65A00) performs those duties previously identified above (paragraph 2-8 a).

*b. Psychiatric/Mental Health Nurse.* The psychiatric/mental health nurse (MAJ, AN, AOC 66COO) provides specialized nursing care and management of BF casualties. This position should be filled by clinical nurse specialist (AOC 66C7T). The duties of the psychiatric/mental health nurse are consistent with those previously identified above (paragraph 2-8 b).

*c. Clinical Psychologist.* The clinical psychologist (CPT, MS, AOC 731367) assigned to the section performs those duties previously identified above (paragraph 2-8 c).

*d. Senior Behavioral Science Noncommissioned Officer.* The senior behavioral science NCO (E-7, MOS 91G40) is also the detachment NCOIC. He assists the combat stress restoration team leader with the accomplishment of his duties. He provides assistance with the management of technical and tactical operations of the team. His specific duties include—

- Keeping the team leader informed.

- Monitoring, facilitating, and supervising the training activities of subordinates.

- Monitoring and coordinating situation reports from deployed combat stress preventive teams.

- Conducting classes on selected mental health topics for senior NCOs of supported units.

*c. Psychiatric Noncommissioned Officer.* The psychiatric NCO (E-5, MOS 91F20) manages and provides supervision for BF casualty care. He deploys with the combat stress restoration team to supervise and function as the BF casualty care manager for the restoration center. He assists with establishment, disestablishment, and movement of the team. The psychiatric NCO also assists with conducting restoration and reconditioning center operations. His duties are consistent with those identified above (paragraph 2-8 f). As a squad leader, he may provide direct supervision for up to 12 BF casualties. He may be deployed temporarily to reinforce a combat stress preventive team.

*f. Psychiatric Specialist.* The psychiatric specialist (E-4, MOS 91F20) provides BF casualty care and intervention, as required. His duties are consistent with those identified above (paragraph 2-8 g). This specialist may be temporarily deployed to reinforce a combat stress preventive team. In addition to his duties, he operates and maintains the assigned vehicle.

*g. Behavioral Science Noncommissioned Officer.* The behavioral science NCO (E-5, MOS 91G20) assists the clinical psychologist. His duties are consistent with those identified above (paragraph 2-7 d). He assists with the management of the combat stress restoration team. This NCO may be assigned temporarily to reinforce/augment a combat stress preventive team.

*h. Behavioral Science Specialist.* The behavioral science specialist (E-4, MOS 91G20) assists the mental health officer in gathering social and psychological data to support BF casualty evaluations. His duties are consistent with those identified above (2-7 *e*). In addition to his duties, he operates and maintains the assigned vehicle. He may be deployed to reinforce/augment a combat stress preventive team.

*i. Occupational Therapy Noncommissioned officer.* The OT NCO (E-5, MOS 91L20) assists the occupational therapist. His duties are consistent with those identified above (paragraph 2-8 *j*). He also functions as team leader for up to 12 BF casualties in restoration.

*j. Occupational Therapy Specialist.* The OT specialist (E-4, MOS91L20) works under

the supervision of the occupational therapist and OT NCO. His duties are consistent with those identified above (paragraph 2-8 *k*).

*k. Patient Administration Specialist.* The patient administration specialist (E-4, MOS 71G20) is responsible for initiating the reports and forms identified in paragraph 2-8 *m* above. He maintains the Daily Disposition Log. He interfaces with the supporting MTF's patient administration section on arrival and disposition of HOLD category BF casualties. He coordinates evacuation and transportation requirements, as required. He maintains assigned vehicle and operates the detachment radio. He coordinates the disposition of BF casualties through the supporting unit's radio communications net.

## CHAPTER 3

## COMBAT STRESS CONTROL OPERATIONS IN THE COMBAT ZONE

### Section I. DIVISION MENTAL HEALTH/COMBAT STRESS CONTROL OPERATIONS

#### 3-1. Division Mental Health Section Deployment

If the division deploys tactically, the division mental health section deploys the brigade CSC teams by echelon with the brigade FSMCs. A team consists of one mental health officer plus an NCO. When the division is assembled in an assembly area or garrison, the mental health officers may consolidate at the MSMC. The division psychiatrist deploys with the MSMC or earlier as needed. The division psychiatrist covers the MSMC in the DSA and uses it as a base of operations. Those division mental health section assets that were not deployed with the FSMCs will establish the division mental health section near the area support squad treatment element (division clearing station). As stated in Chapter 2, the division mental health section routinely details one behavioral science NCO to each of the brigades; these NCOs perform the functions of brigade CSC coordinator. The mental health officers from the division mental health section are designated as the brigade mental health officers. They join the brigade CSC coordinators to form the brigade CSC teams when the brigades deploy away from the MSMC. Other division mental health section personnel are deployed to the supported BSAs to augment/reinforce the brigade CSC teams as required. The division psychiatrist actively supports the brigade CSC teams in their unit-based preventive mental health and training programs and will also deploy to brigade level to provide assistance, or make consultation site visits to the FSMCs. During tactical operations, the division psychiatrist provides a 24-hour NP triage capability at the MSMC. He trains and supervises MSMC treatment platoon personnel in all areas pertaining to

NP and CSC to include handling and treatment of NP patient and combat stress-related casualties. The psychiatrist also initiates the coordination for corps CSC augmentation as required.

#### 3-2. Division Combat Stress Control Estimate and Plan

a. *Mental Health/Combat Stress Control Estimates.* The division psychiatrist, assisted by the division mental health section staff, prepares mental health/CSC estimates as directed or required for CHS operations. Mental health/CSC estimates are developed in accordance with FM 8-55, FM 8-42 and division CHS TSOPs (see Appendix B). Mental health/CSC estimates are submitted via technical medical channels to the DMOC which collects them for the division surgeon. Estimates are provided via command channel (if formal tasking) through the MSMC and MSB headquarters to the DMOC which collects them for the division surgeon. The division psychiatrist may coordinate directly with the division surgeon or DMOC to obtain division/DISCOM staff input. These estimates are used by the division surgeon and DMOC to develop the division CHS OPLANs/OPORDs. The mental health/CSC estimate may include—

- Mental health status of the division.
- Current status of morale and unit cohesion in division units.
- Status of mental health/CSC personnel/elements.

- Battle fatigue casualty estimates.
- Fatigue, sleep loss.
- Percent of casualties; intensity of combat.
- Home-front stressors (natural disaster, unpopular support of the conflict, terrorist attacks in or around home base).
- Restoration requirements.
- Corps CSC support requirements.

The mental health/CSC estimate should include any assumptions required as a basis for initiating, planning, or preparing the estimates. Any mental health/CSC deficiencies are identified, using those tactical courses of action listed in the commander's estimate. The advantages and disadvantages of each tactical course of action under consideration from the mental health/CSC standpoint are provided. In addition, the estimate provides methods of overcoming deficiencies or modifications required in each course of action.

*b. Mental Health/Combat Stress Control Plan.* The division psychiatrist, assisted by the division mental health section staff, develops the mental health/CSC input for the division CHS OPLAN/OPORD in accordance with FMs 8-55 and 8-42. This input is based on the mental health/CSC estimate and feedback from the commander, MSB support operations section, DMOC, and division surgeon. The division psychiatrist and mental health officers must ensure that all mental health/CSC requirements for the division are included in their input for the division OPLAN/OPORD. The mental health/CSC subparagraph in the CHS annex of the division OPLAN/OPORD should include—

- Providing divisionwide mental health/CSC coverage.
- Ensuring policies and procedures for the prevention, acquisition, restoration, and treatment for BF, misconduct stress behavior, and NP disorders are clearly defined and disseminated.
- Providing consultation services.
- Establishing restoration areas as required at division MTFs.
- Coordinating requirements for mental health/CSC augmentation.
- Providing reconstitution support.
- Coordinating for corps-level mental health/CSC support.
- Establishing procedures for the timely and accurate reporting of BF, misconduct stress behavior, and NP disorders seen by division mental health section elements/personnel.

The division psychiatrist, assisted by the mental health staff, is responsible for supervising and coordinating the implementation of the division mental health/CSC support operations. Implementing the mental health/CSC support in accordance with CHS annex of the division OPLAN/OPORD should include—

- Ensuring that DSA and BSA consultation duties are delineated.
- Coordinating as required and permitted by the MSMC and MSB commander with the DMOC and supporting corps CSC elements.

- Coordinating the establishment of restoration and reconditioning centers with supporting corps-level CSC elements.
- Establishing procedures for units to request mental health/CSC support.
- Deploying and reinforcing brigade CSC teams and other division mental health section personnel, as required, to support CSC requirements.
- Ensuring transportation of BF casualties in nonambulance vehicles (such as cargo trucks returning empty after delivering their loads) is coordinated by the DMOC in accordance with the TSOP.

### 3-3. Division Mental Health Section Employment

The employment concept for mental health support in the division is dependent on the effectiveness of the division combat, mental fitness program. It is also dependent on the assignment and proper distribution of division mental health personnel. It is essential that medical commanders promote training which include field experience and cross-training of critical non-medical skills. For division mental health personnel to fill their roles in combat, they must be thoroughly familiar with the units they support. They must also be known and trusted by the leaders and personnel of the supported units.

*a. Division Mental Health/Combat Stress Control Support.* The MSMC commander prioritizes division mental health section missions based on input from the division psychiatrist and on the provisions of the division CHS plan. The division mental health section coordinates through the MSMC commander, MSB support operation, and the DMOC when requesting

mental health/CSC augmentation. Request for corps-level mental health/CSC support is normally coordinated by the DMOC with the supporting medical brigade or group. The deployment of the medical detachment, CSC is discussed in Section III of this chapter. It must be recognized that corps CSC assets can be diverted to other areas of the corps by the medical brigade or medical group even during heavy combat. The medical detachment, CSC may be deployed for peacetime contingency operations. The medical detachment, CSC support is likely to be intermittent and selective in OOTW (conflicts). The division mental health section plans must be prepared to provide CSC coverage without augmentation.

#### *b. Brigade Mental Health/Combat Stress Control Support.*

(1) A behavioral science NCO is routinely detailed to each FSMC to assist the brigade with CSC. This NCO performs duties as the mental health liaison NCO and brigade CSC coordinator. He works for the brigade surgeon under the general supervision of a division mental health section officer. Specifically, one mental health officer from the division mental health section is designated as the brigade mental health officer. The brigade CSC coordinator routinely circulates throughout the brigade to train and advise brigade and supporting personnel to include—

- Medical personnel.
- Chaplains.
- Combat lifesavers.
- Unit leaders.
- Soldiers (unit members).

The brigade CSC coordinator establishes and conducts unit preventive mental health and training programs for the supported brigade and attached units operating with the brigade.

(2) When a brigade is deployed forward, the brigade mental health officer (with a division mental health section vehicle) and (optionally) a behavioral science specialist will also deploy to the BSA. The brigade mental health officer and the brigade CSC coordinator together form the brigade CSC team. The brigade CSC team visits supported units regularly within the BSA and goes forward for consultation to the supported maneuver battalions, as transportation and other missions permit. The brigade mental health officer advises the FSMC on mental health/CSC issues and provides technical supervision for treatment of NP or BF casualties. He provides direct supervision for other division mental health section personnel deployed to the BSA. The brigade mental health officer ensures adequate professional standards for all counseling by CSC coordinators and for command consultation activities.

(3) Severe BF or NP cases which cannot be managed at the FSMCs clearing stations are evaluated by the brigade CSC team. These cases may be sent to the MSMC for evaluation by the division psychiatrist or his representative. No NP or BF casualty is evacuated from the division without being evaluated by the division psychiatrist or his representative.

(4) The division psychiatrist may also deploy to units throughout the division in response to requests for consultation. The division psychiatrist regularly visits the brigade CSC teams in the BSA and reinforces them at times of special need. He identifies problems in units and provides or coordinates consultation following critical events such as a fatal accident, rear battle incident with loss of life, or other cata-

strophic events. The psychiatrist and mental health officers provide CSC prevention training, consultation, critical event debriefing, and restoration support when indicated.

(5) The brigade CSC teams deploy with the supported brigade CSS elements to their BSAs. The brigade CSC teams maintain knowledge of the tactical situation, normally through the brigade surgeons. They assist the brigade surgeons with planning and projecting requirements for stress casualty prevention and reconstitution support. It is important that the brigade CSC teams keep the brigade surgeons and supported commanders updated on CSC issues. The brigade CSC teams also have a responsibility to keep the division psychiatrist informed in accordance with the TSOP. The brigade CSC teams request reinforcement from the division mental health section, as required, especially when there is an increase in the stress casualty and NP caseloads that are beyond their capability to handle. When reinforced, the brigade CSC team orients and updates the mental health/CSC augmenting personnel on CSC issues and requirements. The brigade CSC teams use the clearing stations of the FSMCs as the centers of their operations but must not be confined to that location. The priorities of functions for brigade CSC teams in support of the brigades are—

(a) Deploying forward to ambulance exchange points (AXPs) and combat trains to provide preventive support and immediate stress control intervention when possible.

(b) Triaging BF casualties, misconduct stress behaviors, and NP disorders prior to their evacuation, and advising the attending physician to prevent overevacuation.

(c) Facilitating the treatment of BF REST category cases in their battalions' field trains.



(d) Advising FSMC health care providers on treatment requirements for BF casualties.

(e) Coordinating the RTD process for recovered BF casualties.

(f) Facilitating postcombat stress debriefings at small units.

(6) The employment of the medical detachment, CSC provides for a CSC preventive team to augment the brigade CSC team at the FSMC in each BSA. The CSC preventive team has a psychiatrist, social work officer, and two behavioral science specialists. This team has a 5/4-ton vehicle for transportation. This corps CSC preventive team could be diverted elsewhere. The brigade CSC team and brigade must be prepared to function without them. The mission of the CSC preventive team is discussed in Section III of this chapter.

c. *Unit-Level Mental Health/Combat Stress Control Support.* Unit-level mental health/CSC support is provided by the brigade CSC team and the division psychiatrist, as required. The brigade CSC team officer and the NCO (or the brigade CSC coordinator alone) conduct site visits to all the units in the BSA on a frequent basis. The brigade CSC team ideally has preestablished points of contact (officers and NCOs) in each unit. Site visits by the brigade CSC team to supported units are performed for several reasons which involve both the units and the brigade CSC team. The primary reasons for these frequent site visits include—

- Establishing trust and confidence between the brigade CSC team and unit personnel.
- Establishing familiarity with the unit's operations, mission, and tasks and

being able to converse with unit personnel and understand about what they do.

- Monitoring units for morale, unit cohesion, and indicators of excessive stress/stressors.
- Advising unit commanders, leaders, and personnel on stress management and coping techniques.
- Identifying, providing, or coordinating training on mental health/CSC subject areas.
- Providing preventive consultation.
- Providing feedback to the brigade surgeon and division psychiatrist on the mental health status of supported units.
- Monitoring the progress of REST and DUTY category BF soldiers that are recovering in their units.

(1) When a division mental health section's vehicle is in the BSA, the brigade CSC team uses this vehicle to visit supported units. If a designated vehicle from the division mental health section is not available (as when the brigade CSC coordinator is working without the brigade mental health officer being present), it is necessary to find alternative means of getting to the supported units. The transportation needs are dependent on the size of the BSA and the amount of traffic movement between units. In some situations when there are short distances between units, it may be feasible for the brigade CSC team to walk to the supported units located in the BSA or to coordinate rides with unit vehicles. The unit ministry teams (chaplains) can be especially helpful because of the common features of CSC and the chaplains' ministry and CSC support.

(2) The brigade CSC team must keep the FSMC informed of their whereabouts. This is done by reporting to the FSMC (using the visited unit's radio or land lines) immediately upon arriving and again just before departing, specifying the next destination. The brigade CSC team provides updates on the CSC situation at the unit just visited by using short brevity-coded messages. This constant contact with the FSMC permits the redirecting of the brigade CSC team to areas of special need.

(3) When combat is imminent or ongoing, the brigade CSC team may deploy forward to the AXP's to provide rapid evaluation and CSC intervention. The brigade mental health officer and brigade CSC coordinator may be at different locations. In some situations, one or both may go forward to a battalion aid station (BAS) located in the combat trains area.

(4) During lulls before or after combat actions, the brigade CSC coordinator may go forward to unit combat trains and BASS for preventive consultation. They meet with a unit in reserve that has experienced intensive combat or other problems. The brigade CSC team may use the division mental health section vehicle, ride in ambulances, or travel with the logistic package convoy or reconstitution teams going forward. The brigade CSC team updates and assists any mental health/CSC personnel sent to the brigade for reinforcing/augmentation support.

*d. Clinical Duties of the Brigade Combat Stress Control Team in the Brigade Support Area.* The brigade CSC team provides assistance to unit-level medical officers and physician assistants, as required, to ensure correct disposition for BF, misconduct stress behavior, and NP cases. At the BSA, the brigade CSC team assists in patient triage and in the evaluation of problematic BF and NP cases. The brigade CSC team assists the attending physician and patient-holding wardnaster in providing general guidance and

training for patient-holding squad personnel. The CSC team's guidance and training will include the emotional and behavioral aspects of patient care for the minimally sick and wounded as well as for BF and NP cases. Following the treatment protocol established by the division psychiatrist, and in accordance with the mental health/CSC plan, the brigade CSC team makes recommendations on the triage, management, and treatment of combat stress-related cases. Triage of BF cases into the appropriate categories is essential for effective management and treatment. Management and treatment of the following triage categories are examples of how the brigade CSC team can manage combat stress-related casualties in the BSA. Additional information on combat NP triage, restoration, and consultation is provided in subsequent chapters. The BF casualty may be triaged and placed in one of the following categories:

- DUTY
- REST
- HOLD
- REFER

(1) Mild BF cases who reach the brigade MTF will be triaged as DUTY category. Some of these cases will require a brief time to recuperate (less than an hour to no more than 6 hours). This short period for recovery may include—

- Food and nourishment.
- Fluid to drink.
- A quiet place to nap.
- Reassurance to the sol-

dier.

- The opportunity for talking about his experiences.

The DUTY category cases are sent back to their units with recommendations for full duty. If the soldier's unit is known to be in reserve status where everyone is resting and recovering, a lower level of combat functioning could still qualify as DUTY BF. However, if a soldier is classified as DUTY, he must be capable of caring for himself and responding appropriately to his duties if the unit comes under attack.

(2) REST category cases from maneuver units may require being away from far-forward areas for a few days. Normally, these cases are sent for 1 to 2 days of duty in the soldiers' own battalion HSC or battery. Alternatively, these soldiers may be held in BSA units under the control of the FSMC or brigade Adjutant (US Army) (S1) for 1 or 2 days. In both situations coordination is required, and the soldier must be accounted for until he returns to his own unit. REST category cases placed in units are monitored by the brigade CSC team. The brigade CSC team monitors these cases either by direct interview or by talking with the soldier's supervisors. The brigade CSC team listens to the soldier's story and gives perspective-reorienting counseling when indicated. REST cases are returned to the FSMC and placed in the HOLD category if symptoms persist and they fail to improve. These cases will be provided restoration treatment and additional evaluation at the FSMC. These cases are accounted for until they RTD with their own units.

(3) HOLD category BF cases are those who require medical observation and assistance. If feasible, these cases are provided restoration treatment at the FSMCs for 1 day (or up to 3 days if RTD is expected). When these cases are held in the FSMC's patient-holding area, it should be emphasized to them that BF soldiers are not patients, just tired soldiers. The

feasibility of holding BF casualty cases at the FSMC depends on the tactical situation, patient work load, and the soldiers' symptoms. Restoration treatment for HOLD category cases placed in the patient-holding area of the FSMC includes—

- Reassuring that BF is normal and temporary.
- Providing a respite from extreme danger or stress.
- Ensuring dehydration.
- Providing replenishment (food and hygiene).
- Providing the opportunity for rest (sleep).
- Recounting (verbally reconstructing) the recent stressful events and regaining perspective.
- Restoring confidence through activities which maintain the individual's identity as a soldier.

(4) REFER category are BF and NP cases which cannot be safely held or treated at the FSMC. These cases may be triaged into the REFER category at the initial evaluation or they may be cases that have not responded to initial restoration treatment at the FSMC. These cases are evaluated at the FSMCs by the division psychiatrist or mental health officers if they are in the forward areas, or they are sent to DSA clearing station for evaluation and disposition by division mental health section or the designated alternates. The preferred method of evacuating these cases is by nonmedical vehicle, but ground ambulances are used, as necessary. Physical restraints and/or medication are used during transportation only if necessary for safety.

## NOTE

A few BF or NP symptoms could also be caused by life- or limb-threatening medical/surgical conditions. These casualties may be evacuated directly to a corps-level hospital as determined by the attending physician.

Wounded casualties with concurrent BF or NP symptoms, who are either combative or violent, are placed in patient restraints as determined by the attending physician. If these types of patients are evacuated by air ambulance, physical restraints are required. The preferred method of transporting an unwounded BF casualty is by a nonmedical vehicle. The use of a nonmedical vehicle would help prevent the BF casualty from thinking that his condition is anything other than just being a very tired soldier. On the other hand, by placing the BF casualty in an ambulance which is clearly marked with the symbol of the red crosses, the BF casualty is under a protected status according to the rules established by the Geneva Conventions. The decision that confronts the health care provider is which of two methods is more beneficial for the overall safety and recovery of the BF casualty.

*e. Mental Health/Combat Stress Control Support in the Division Support Area.* The division mental health section personnel locate near and work with the DSA clearing station to ensure mental health/CSC coverage to support the DSA is available. They evaluate BF, misconduct stress behavior, and NP cases referred from throughout the division AO. The initial triage of cases from the DSA is the same as performed in the BSAs. The division mental health section staff in the DSA spends substantial time with evaluating the REFER category BF casualty sent from the forward areas of the division. Any of the REFER cases with good potential for RTD within 72 hours are held for

treatment and placed in the MSMC patient-holding section. The total period of time for holding BF casualties in the division is 72 hours. If the BF casualty is held in the BSA for 24 hours, he can be held in the DSA only for an additional 48 hours. These cases are provided restoration treatment at the MSMC for up to 3 days. The feasibility of holding BF casualty cases at the MSMC depends on the tactical situation, patient work load, and the soldiers' symptoms. Restoration treatment for HOLD category cases placed in the patient-holding section of the MSMC is the same as identified for the FSMCS. The number of days (within the 72-hour time frame) of restoration that the MSMC can provide could be shortened or lengthened, depending on the tactical situation, available resources, and the actual or projected caseloads.

(1) The division psychiatrist, assisted by the clinical psychologist and social work officer (if they are not deployed to the BSAS), exercises technical supervision for the management of BF soldiers and NP patients placed in the patient-holding section. If possible, these cases are housed away from the ill, injured, or wounded patients.

(2) The division psychiatrist may designate a behavioral science specialist to assist the patient-holding squad with treatment of BF casualties. This treatment consists of replenishing sleep, hydration, nutrition, hygiene, and general health and restoring confidence through group activities, appropriate military work details, and individual counseling, as needed. These activities include those patients with minor wounds, injuries, and illnesses who do not need continual bed rest and who may have BF symptoms.

(3) The division psychiatrist follows the soldiers' progress, reevaluates, and gives individual attention, as needed. Medication is prescribed sparingly and only when needed to

temporarily support sleep or manage disruptive symptoms. Those cases who (on initial evaluation or after a period of observation) have a poor prognosis for RTD, or whose behavior is too disruptive or dangerous to manage in the holding facility, are evacuated to the supporting corps-level hospital. Such patients must be suitably restrained and medicated for transport. The evacuation priority for these NP patients is routine.

(4) Those cases who (on initial evaluation or after observation) require longer than the holding policy at the division-level MTF allows but who have reasonable prognosis for RTD within the corps evacuation policy are transferred to a corps-level restoration and reconditioning facility. Corps restoration and reconditioning facilities are staffed and operated by the medical company, CSC.

(5) Soldiers sent directly from a division MTF to a restoration and reconditioning center will ideally be transported in trucks, not ambulances. Prior coordination with the division Assistant Chief of Staff (Personnel) (G1) and corps Adjutant General (AG) personnel replacement system may facilitate the returning of recovered BF casualties to their original units.

(6) For all recovered BF soldiers returned to duty from the DSA, the division mental health section coordinates with the division G1 and with the soldier's unit. The coordination is made directly or through the CSC coordinator in the DSA or brigade CSC team in the BSAS, the chaplains' ministry, or other channels. This is to ensure successful reintegration of these soldiers back into their units.

*f. Division Support Area Combat Stress Control Coordinator.* The CSC coordinator in the DSA performs functions similar to those of the brigade CSC coordinators for units located in the division rear but on a less independent scale.

He works under the direct supervision of the division psychiatrist or the division mental health section NCOIC. The CSC coordinator's activities can be closely supervised and reinforced by the division psychiatrist; this position requires less experience and independence than the brigade CSC coordinators. This is a suitable preparatory training assignment for less senior behavioral science specialists before they become brigade CSC coordinators. However, the special problems of BF in CS and CSS units in the rear area make the DSA CSC coordinator's role no less important to the success of the division. It is essential to assign an individual with whom the units can identify and develop trust.

(1) During lulls in tactical activities, the DSA CSC coordinator conducts classes on mental fitness; provides consultation for unit leaders; provides crisis intervention counseling for soldiers; and gives counseling and referral for troubled soldiers.

(2) During tactical operations, the DSA CSC coordinator keeps current on the location and status of CS/CSS units, continues to provide consultation to these units, and coordinates the resting of DUTY and REST BF soldiers in or near their units.

### **3-4. Reinforcement of Brigade Combat Stress Control Team Using Division Mental Health Section Assets Only**

*a. Consultation Visits.* Frequent visits to the BSAs and their brigade CSC teams should be scheduled on a routine basis by the division psychiatrist. These consultation visits may last hours or even 1 to 2 days. The division psychiatrist, in coordination with the MSMC commander, the DMOC, and the division surgeon, should consider enhancing support in the forward areas—

(1) When increased numbers of cases are being evaluated and followed at an FSMC such that the brigade CSC team cannot provide continuous coverage and still perform their consultation mission.

(2) If a member of the brigade CSC team becomes a casualty.

(3) When (in a static tactical situation) there are more cases who can be held for treatment at a particular BSA clearing station than its holding squad staff can manage.

(4) When conditions do not permit REFER cases to be evacuated to the DSA for evaluation.

(5) When there is a mass casualty situation and additional BF and NP diagnostic expertise is needed to triage those patients who require immediate evacuation and those who can be treated locally for quick RTD.

(6) When a battalion- or company-sized unit stands down (pulled back) for rest and recuperation or for regeneration. When the reconstitution process requires regeneration of heavily attrited units, mental health/CSC personnel should deploy along with other CSS contact teams to assist surviving members, assuring that all members get good quality rest and physical recuperation. During the “after-action debriefing,” mental health/CSC personnel assist surviving members to review their recent combat experiences and restore a positive coping perspective to the group. Mental health/CSC personnel also assist with integrating survivors and replacements into cohesive teams (see Chapter 5).

*b. Options for Reinforcing the Brigade Mental Health/Combat Stress Control Support.* The division psychiatrist may use the following

options to reinforce the brigade CSC teams in the forward areas with division mental health section assets:

(1) Send one behavioral science specialist to reinforce a brigade CSC team at the FSMC holding facility.

(2) Place two brigade CSC teams temporarily in support of a brigade that has large numbers of BF casualties.

(3) Deploy himself forward to supervise and assist the brigade CSC team until the situation or crisis has been resolved.

### 3-5. **Corps-Level Mental Health/Combat Stress Control Support Reinforcement**

The division psychiatrist should consider requesting additional corps-level mental health/CSC augmentation when—

- Caseload and/or geographical dispersion prevents the division mental health section from providing divisionwide consultation services.
- Combat stress-related casualties are beyond the treatment capabilities of division mental health section and whatever corps CSC assets that are attached.
- A battalion or brigade is withdrawn from a forward area back into the DSA for rest and reconstitution.
- Enemy forces have used NBC weapons.
- Other high stress factors (such as heavy losses as a result of prolonged and intense battles) are present.

The division psychiatrist may request, through the MSMC commander, the MSB support operations section, and the DMOC, reinforcing CSC support from corps. The DMOC coordinates corps CSC support with the medical brigade or group. Mental health/CSC support

from the corps will be provided by the medical detachment, CSC or by elements from the medical company, CSC. Both the medical company, CSC and medical detachment, CSC operations are discussed in Sections III and IV of this chapter.

## Section II. AREA SUPPORT MEDICAL BATTALION MENTAL HEALTH/COMBAT STRESS CONTROL SUPPORT OPERATIONS

### 3-6. Mental Health Section Employment

a. *Area Support Medical Battalion Mental Health Support.* The ASMB mental health section deploys with the HSC of the ASMB. When the ASMB deploys tactically, the mental health section collocates with the battalion headquarters but disperses its personnel and resources to support the ASMB's entire AO. The ASMB commander prioritizes the area mental health support mission based on input from the ASMB psychiatrist and battalion medical operations center in accordance with medical brigade/group and ASMB CHS plans. Battalion CP personnel coordinate with the ASMB psychiatrist and the ASMCs for the deployment of the mental health section's assets to support their AO. Each ASMC is normally allocated one NCO CSC coordinator. The battalion CP, in consultation with the ASMB psychiatrist, should consider enhancing mental health/CSC resources within an ASMC's AO when—

- Stress-related casualties are beyond the treatment capabilities of an ASMC and its CSC coordinator.
- A battalion- or company-sized unit is withdrawn from a forward area back into the ASMC AO for rest and regeneration.
- Enemy forces have used NBC weapons.

- Other high stress factors occur, to include—
  - Major accidents or disasters to a unit.
  - Heavy losses as a result of rear battles.
  - Friendly fire incidents.
  - Heavy casualties or suffering among noncombatants.

The ASMB psychiatrist may use four options to reinforce mental health support within the supported AO:

- (1) Send one junior behavioral science specialist to the patient-holding section of the ASMC to reinforce the CSC coordinator previously deployed from the mental health section.
- (2) Send the social work officer or the ASMB psychiatrist to the ASMC. This allows the CSC coordinator to relocate to other areas, as necessary. This officer can go unaccompanied to other locations within the supported AO. The CSC coordinator coordinates the requirements for such actions with the ASMC headquarters element.

(3) Use one mental health officer and one behavioral science specialist for a mobile team. They are provided a vehicle for movement to each location. The mobile team has the flexibility to move and provide CSC support at successive locations.

(4) Augment the mental health section with a CSC team from the supporting CSC company or detachment. Augmentation of mental health personnel should be considered (or planned) for all scenarios in which increases in BF and NP casualties are anticipated. The mental health section coordinates through the ASMB commander and battalion CP when requesting additional mental health/CSC support. The ASMB CP (medical operations center) forwards requests for mental health/CSC augmentation through the medical brigade/group to the CSC company. In the COMMZ, the request is sent to the medical brigade.

*b. Area Mental Health/Combat Stress Control Support Operations.* Upon deployment of the ASMB to its AO, area mental health support operations begin. The psychiatrist and one or two junior behavioral science specialists routinely locate at and work with the HSC clearing station. The social work officer and NCOIC (senior behavioral science specialist) may also locate with the HSC clearing station or with the battalion headquarters.

(1) The social work officer and NCOIC as directed by the battalion psychiatrist coordinate mental health section activities with the battalion CP. Coordination includes activities such as traveling to ASMCs and supported units and obtaining status updates of ASMCs and supported units. The social work officer and NCOIC actively support the CSC coordinators in their unit-based preventive mental health and training programs. They provide technical supervision and quality assurance over all the

CSC coordinators' counseling and command consultation activities.

(2) One behavioral science NCO from the mental health section is allocated to each ASMC where he routinely serves as the mental health section's CSC coordinator for the supported AO. The CSC coordinator provides behavioral science advice to the ASMC commanders and treatment teams in assessment and triage. He trains the patient-holding squad personnel in management of stress casualties who must be held for restoration and treatment. The CSC coordinator also trains patient-holding squad personnel in stress intervention techniques for other DNBI patients. He visits units throughout the AO to routinely support recovery of DUTY and REST category BF soldiers. In addition to the above, the CSC coordinator will—

- Assist with the reintegration of recovered BF casualties into their original or new units.
- Provide command consultation.
- Conduct training for leaders in stress control principles and techniques.
- Facilitate after-action debriefings.
- Conduct critical incident stress debriefings, as necessary.

(3) To foster a good working relationship with supported units, the CSC coordinator (and all mental health personnel) should deploy to observe the unit at work or in tactical training exercises. The mental health/CSC mission objective is to become familiar with each of the different types of units and includes the—



- Unit's mission.
- Equipment.
- Vocabulary (words and operational or technical terms which are commonly used in the unit).
- Working conditions.
- Typical stressors.

This knowledge is essential to gain the trust and confidence of the unit's leaders and troops. It is necessary information for evaluating soldiers and their mental fitness to perform duties.

### 3-7. **Disposition of Battle Fatigue and Neuropsychiatric Cases from the Area Support Medical Battalion**

The ASMCs refer BF and NP cases who cannot be managed at the ASMC clearing stations to the psychiatrist at the HSC clearing station as soon as tactical conditions permit.

*a. Preferred Method of Transport for Battle Fatigue and Neuropsychiatric Cases.* The preferred method of transport for those BF and NP cases that are manageable without the use of

medication or restraints is by a nonambulance ground vehicle. If physical restraints and/or medications are required during evacuation, the preferred method of transport is by ground ambulance. An air ambulance should be used only if no other means of transportation is available. Physical restraints are used only during transport and medications are given only if needed for reasons of safety.

*b. Time and Distances Factors.* When time and distance factors preclude the evacuation of BF and NP cases to the HSC, these cases may be evacuated to the nearest CSH, field hospital (FH), or general hospital (GH) for evaluation and treatment by that hospital's NP service. (These cases are not evacuated to a mobile army surgical hospital [MASH].) Consultation with the ASMB psychiatrist via telephone or radio is appropriate prior to evacuation. Direct evacuation from the ASMC clearing stations is accomplished without consultation when the BF or NP patient also has a life- or limb-threatening medical or surgical condition, or a life-threatening NP condition (for example, a suicide attempt) which cannot be stabilized at the ASMC clearing station. This decision is made by the attending physician, but ideally, the CSC coordinator should be advised. Cases with true NP disorders, or who do not respond to brief restoration treatment, are evacuated to supporting corps hospital or to the medical company, CSC.

## **Section III. SUPPORT OPERATIONS CONDUCTED BY THE MEDICAL DETACHMENT, COMBAT STRESS CONTROL**

### 3-8. **Medical Detachment, Combat Stress Control Employment**

*a. Medical Detachment, Combat Stress Control Support Operations.* The CSC medical detachment is assigned to a medical group or

other medical C2 headquarters and may be further attached to supported medical companies or medical company, CSC. Its employment in the theater depends on the intensity of the conflict. The medical detachment, CSC is employed in all intensities of conflicts whenever

a division or two separate brigades/regiments are deployed.

*b. Support for Division Combat Operations During War.* The medical detachment, CSC may be attached to the CSC medical company for C2. The detachment receives administrative and maintenance support from the CSC company headquarters. The detachment's teams are reinforced or provided personnel replacements by CSC teams or task-organized CSC elements from the company when necessary. A CSC detachment, which supports a division is usually attached to the supported division's MSMC of the MSB. It is under the operational control of the MSB and MSMC but works under the technical supervision of the division psychiatrist and division surgeon. Long-term relationships of CSC detachments with specific divisions are standard. However, as a corps asset, the detachment (or its modular teams) may be cross-attached to support other units or missions as work load requires. It depends on the unit(s) to which it is attached for administrative and logistics support.

(1) Upon the initial attachment of the detachment, its three 4-person CSC preventive teams are usually further attached. One CSC preventive team is attached to each FSMC well before combat is imminent. This permits them to link up with and augment the brigade's CSC team and the FSMC. Each CSC preventive team provides another mental health officer and a psychiatrist (with a behavioral science specialist and vehicle) to increase triage, stabilization, and restoration capability at the FSMC. The CSC preventive team performs the following:

- Conducts regular visits to the BSA to provide consultation throughout the FSB while the CSC restoration team is further forward.

- Operates further forward during ongoing combat by cross-exchanging personnel with the brigade CSC team.

- Deploys to provide reconstitution support to units undergoing hasty or deliberate reorganization.

In some operations, however, some or all of the CSC preventive team personnel may remain back at the supporting corps-level medical company or be concentrated at another brigade or reconstitution site with a heavier work load.

(a) While the brigade is on the move, BF soldiers who cannot return immediately to their forward units may be rested and transported by their own unit's field trains. They eat, drink, restore hygiene, catch up on sleep, talk, and perform useful duties while regaining full effectiveness on the move. The readiness of units to keep such cases will depend on their knowing that trusted CSC personnel are present as backup. The BF cases who require medical observation for only a few hours are transported with the CSC preventive teams and the FSMC.

(b) Any stress casualties who require *more* extensive restoration must be transported to the rear echelon of the medical detachment, CSC at the MSMC. Transportation in backhaul supply trucks is preferred to ground or air ambulances for most BF casualties. If the distances involved require the use of supply helicopters or air ambulances, the CSC personnel must assure that the BF casualties do not overfly the next echelon and are not evacuated further to the rear than necessary.

(2) The medical detachment, CSC's 11-person CSC restoration team (including the NCOIC of the headquarters section) remains with the division mental health section at the MSMC in the DSA. The detachment has tents and equipment to operate a restoration center and provides expertise in clinical psychology, psychiatric nursing, and OT. The center provides intensive restoration treatment for RTD within 3 days. The CSC restoration team provides triage and stabilization at the MSMC and consultation

to nearby division units. The CSC restoration team staff may go forward by truck or air ambulance to temporarily reinforce or reconstitute a CSC preventive team at the brigade, or to escort BF casualties in truck backhaul to the restoration center. The CSC restoration team personnel give reconstitution support to attrited units, especially when the units return to the DSA. The CSC restoration team supplements the division psychiatrist, brigade CSC teams, CSC preventive teams, and chaplains and leaders in after-action debriefings. They help integrate the recovered soldiers and new replacements into the units during reorganization activities.

(3) The medical detachment, CSC and its elements are dependent on the units to which they are attached for food, water, fuel, maintenance, and administrative support.

(4) When the DSA is tactically too unstable to allow restoration, the CSC restoration team and perhaps the CSC preventive section may locate further to the rear. They may locate with an ASMB or a corps hospital which is close enough for them to continue their support to the division.

(5) When all three CSC preventive teams are forward at the brigades, the detachment commander/psychiatrist is forward with one of the CSC preventive teams. This is usually acceptable, as the detachment is attached (operational control [OPCON]) to the MSMC under the supervision of the division psychiatrist. Under some situations, the detachment commander may elect to remain with the CSC preventive team. He may leave his CSC preventive team with only one social work officer and two behavioral science specialists if work load at the BSA is light. In other situations, he may elect to send the clinical psychologist from the CSC restoration team to take his place. The detachment NCOIC and the officers of the CSC restoration team keep the commander informed and represent him as needed. If the division has

only two maneuver brigades, the CSC preventive team which includes the detachment commander normally remains with the division mental health section and CSC restoration team in the DSA.

c. *Support to Separate Brigades or Armored Cavalry Regiments During War.* A separate brigade or ACR in a mid- to high-intensity conflict is dependent on division or corps CSC assets for support.

(1) A medical detachment, CSC which supports two or three separate brigades or regiments is normally attached to the medical group or the medical company, CSC which supports the AO.

(2) If two brigades or ACRs are supported, two of the detachment CSC preventive teams are deployed forward and attached to the FSMCs of the two supported brigades or ACRs. The detachment commander's team locates where it can best provide backup support to the forward elements and coordinates administrative and logistical support. The CSC preventive teams with each separate brigade operate as described above for divisional brigades, except they are reinforcing a brigade CSC team which has only a behavioral science NCO in charge. The ACRs have no CSC team to reinforce. The CSC preventive team, therefore, needs to be much more active in making contact and establishing trust and cohesion with the following elements and personnel:

- Medical company personnel.
- Battalion or squadron medical platoons.
- Brigade or regiment chaplain and unit ministry teams.
- Unit commander and leaders at all levels.

It is especially important that this process begins as far in advance of the onset of combat operations as possible, preferably before deployment.

(3) If a third separate brigade is supported, the detachment commander's CSC preventive team deploys to it.

(4) The CSC restoration team either locates with the detachment commander and provides restoration treatment at that location or augments a corps-level MTF where cases from the supported brigades can best be treated. It integrates its restoration and reconditioning programs with those of the other supporting CSC units.

*d. Combat Stress Control Detachment in Operations Other Than War.* In a prolonged conflict involving a contingency corps with one or more divisions and/or several separate brigades and regiments, only CSC medical detachments (no CSC medical company) maybe mobilized. For contingency operations of short duration, task-organized CSC elements from the CSC medical detachments could be deployed.

(1) The CSC preventive teams supporting the brigades may operate out of a central base of operations. The teams go forward to the BSAS (base camps or fire bases) when coordinated by the division mental health section. Such visits would be in response to—

- Anticipated battle.
- Post-action debriefing requirements.
- Alcohol/drug problems in a unit.
- Incidents of misconduct stress behaviors.
- Unit rotation in or out of theater.

(2) Several CSC restoration and CSC preventive teams from two or more CSC medical detachments may be consolidated under the command of the senior medical detachment, CSC commander to staff a central reconditioning program for the corps. This may also function as an alcohol/drug detoxification rehabilitation program. The CSC center will also provide consultation and treatment support to military police (MP) confinement facilities where misconduct stress behaviors may have led to incarceration (see Appendix C).

(3) In OOTW, if the force deployed is smaller than a division, a medical detachment, CSC would not be required to provide CSC support. In such cases, either the medical company, CSC or the medical detachment, CSC may be tasked with providing either a CSC team or a task-organized CSC element. The CSC team or the task-organized CSC element is attached to the supporting medical headquarters or to an MTF and conducts its mobile consultation mission.

### 3-9. Medical Detachment, Combat Stress Control Interface and Coordination Requirements

The medical detachment, CSC must interface with its higher medical headquarters element and with the unit to which they will be attached. The higher headquarters may be the medical brigade, medical group, medical company, CSC or an ASMB. The medical brigade or medical group which controls a CSC company will normally utilize that CSC company to monitor the CSC detachment. The CSC company makes recommendations regarding the employment and support of any medical detachment, CSC assigned to their AO. This includes CSC medical detachments that have been attached to the supported divisions. The medical company, CSC, in turn, will task its task-organized sections to support specific CSC medical detachments. When

required, the task-organized CSC elements may reinforce or provide replacement personnel for those CSC medical detachments. Maximal communications are encouraged between the CSC medical detachments and the task-organized CSC elements directly through technical channels. The mental health staff sections of the medical brigade and medical group ensure that CSC medical companies are updated. They provide the medical company, CSC headquarters and the relevant task-organized CSC elements with information copies of all status reports received from the CSC medical detachments in their AO. For detailed information pertaining to medical company, CSC headquarters and task-organized CSC elements, see Section IV. Normally, the detachment is attached for OPCON to an MSMC of the MSB in the divisions. If it is supporting in the corps area, then it could be attached to a medical company, CSC, an ASMB, or directly to the medical group. Interface and coordination are essential if CSC support requirements are to be accomplished.

a. *Interface Between the Detachment and Its Higher Headquarters.* The medical detachment, CSC interfaces with its higher headquarters pertaining to its assigned mission. It provides estimates and has input to the OPLANs. The detachment receives its OPORDs from the higher headquarters. Interface between the detachment and the staff of its higher headquarters will focus on providing CSC which includes preventive activities and consultation support. Interface between the detachment and higher headquarters staff elements will include the following subject areas:

- Combat stress control operations.
- Assignment or attachment of the medical detachment, CSC elements.
- Daily personnel and equipment status reports.
- Class VIII (medical supply) status and supply requirements.
- Casualty Feeder Reports.
- Statistical summaries pertaining to work load, including consultation and triage activities, restoration or reconditioning center censuses, and special reconstitution support activities.
- Operation plans.
- Operation orders.
- Personnel replacement for the detachment.
- Medical intelligence information.
- Mental health/CSC consultation taskings and results.
- Maintenance requirements and request.
- Replacement and reconstitution operations.
- Civil-military operations.
- Host-nation support.
- Communications (signal operation instructions [SOI], access to message centers and nets, and transmission of CSC messages through medical and other channels).
- Mass casualty plan.
- Road movement clearances.
- Tactical updates.
- Contingency operations.

- Return-to-duty and nonreturn-to-duty procedures.

- Medical evacuation procedures (air and ground ambulances).

- Changes in locations of supported unit.

*b. Interface and Coordination with the Unit That Has Operational Control of the Medical Detachment. Combat Stress Control.* The headquarters of the unit with OPCON is responsible for providing the administrative and logistical support requirements of the detachment. These requirements are normally identified in the attachment order. If not identified in the attachment order, they must be coordinated by the detachment's higher headquarters prior to deployment. The CSC detachment must coordinate daily with the headquarters staff and section leaders (if required) of the unit to which they are attached. The staff shares information with the detachment commander or his representative. Daily updates pertaining to the threat, tactical situation, patient/BF casualty status, and changes in CHS requirements are provided to the detachment. Coordination activities and subject area information exchange should include—

- Command and control procedures.

- Status of FSMCs and CSC preventive teams.

- Communications (SOI).

- Operational support requirements.

- Civil-military operations.

- Restoration operations.

- Reinforcement and personnel replacement.

- Maintenance.

- Personnel replacement.

- Road movement and clearances.

- Casualty reporting and accountability.

- Patient-holding procedures.

- Nuclear, biological, and chemical defensive operations.

## Section IV. SUPPORT OPERATIONS CONDUCTED BY THE MEDICAL COMPANY, COMBAT STRESS CONTROL

### 3-10. Medical Company, Combat Stress Control Employment

*a. Medical Company, Combat Stress Control Support Operations.* The medical company, CSC is assigned to a MEDCOM, medical brigade, or medical group. The medical company, CSC is employed for a war when estimates indicate large numbers of BF casualties. During

war, one medical company, CSC may support from two to five divisions depending on the level of operations. The company is reinforced by attachment of a variable number of CSC medical detachments. Normally, one CSC detachment is allocated per division and one per two or three separate brigades or regiments in the corps. The medical detachment, CSC is discussed earlier in Section III.

*b. Methods of Operations for the Medical Company, Combat Stress Control.* Methods of operations for the medical company, CSC are dependent on the CSC support requirements and the tactical situation. The CSC medical company commander can deploy modular CSC preventive and CSC restoration teams from the company's preventive and restoration sections. He also has the option to combine elements from both sections to form task-organized CSC elements, depending on CSC requirements. The personnel in the preventive and restoration sections do not have to be task-organized in rigid compliance with the modular CSC preventive and CSC restoration team building blocks. For example, one task-organized CSC element may be given most of the psychiatric nursing assets, while another may receive more of the OT resources. This decision would be based on the shifting requirements set by the reconditioning or restoration caseloads at different places and other priority missions. The intent is to give the commander flexibility to accomplish his changing mission requirements for CSC.

(1) Task-organized CSC element employment. The task-organized CSC elements are employed to provide CSC support in their area of responsibility. They must coordinate with the supporting ASMB and hospital NP resources within their AO. The task-organized CSC element leader is responsible for allocating the CSC resources which the medical company, CSC commander has given his element. He must meet the changing requirements for—

- Preventive consultation and CSC education in the corps (supporting the ASMB) (see Chapter 4).

- Reconstitution support (a major, but intermittent priority mission tasked by the higher headquarters) (see Chapter 5).

- Neuropsychiatric triage (shared with the ASMB and hospital NP consultation services) (see Chapter 6).

- Stabilization under emergency situations; normally, this is the mission of the hospital NP ward/service (see Chapter 7).

- Restoration (in areas where the task-organized CSC element is closer to the soldier's units than an ASMC, or by sending a team to reinforce an ASMC) (see Chapter 8).

- Reconditioning (the unique mission of the CSC company's task-organized CSC elements in corps and in most scenarios, but of lower priority than the missions listed above) (see Chapter 9).

- Temporary support (sending CSC teams to reinforce the medical detachment, CSC which are operating forward in the division and brigade areas, or when reconstitution support and restoration work loads require).

- Reinforcement of the medical detachment, CSC, division mental health section, or ASMB mental health section, if necessary or providing replacement personnel.

(2) Restoration and especially reconditioning are provided for BF soldiers and selected NP and alcohol/drug misuse cases from the supported division and corps units. The task-organized CSC elements attach to or collocate with medical units as near to the supported units as is tactically feasible. In the initial intensive phase of conflict, CSC teams may be dispersed to reinforce the CSC medical detachments in the divisions. They may be attached to an ASMC or a CSH where they can readily support the divisions and heavily committed corps units. In this phase, reconditioning treatment in the corps area will rarely continue beyond 3 days, in addition to the initial 3 days of restoration. As the conflict stabilizes and the requirement for restoration decreases, reconditioning extends to seven days. If feasible, and with approval of the corps commander, it is extended to 14 days. The

task-organized CSC element's combat fitness and reconditioning center is usually attached (not OPCON) to a CSH.

(3) A task-organized CSC element from the medical company, CSC usually deploys in the corps area behind each supported division. The task-organized CSC element behind each division has two or three CSC preventive teams and one to three CSC restoration teams, depending on support requirements. Each task-organized CSC element may be reinforced by one or two support personnel (cook, mechanic) detailed from the medical company, CSC head-

quarters. Each task-organized CSC element sends modular teams forward to reinforce the medical detachment, CSC in the supported division, as needed. Table 3-1 shows the ways that teams could be distributed as task-organized CSC elements to support two to five divisions.

(4) When not task-organized with a CSC preventive team, the CSC restoration teams normally collocate with a CSH or with the HSC of an ASMB. Both the CSH and headquarters and support company of the ASMB provide a psychiatrist. This is of lesser importance if the psychiatric nurse of the CSC

*Table 3-1. Distribution of Six Combat Stress Control Preventive and Four Combat Stress Control Restoration Teams into Task-Organized Combat Stress Control Elements to Support from Two to Five Divisions*

NUMBER OF DIVISIONS SUPPORTED	TOCSCE-A	TOCSCE-B	TOCSCE-C	TOCSCE-D	TOCSCE-E	HQ
2 or 4*	CSCP <sup>2</sup> /R <sup>2</sup>	CSCP <sup>3</sup> /R <sup>2</sup>	—	—	—	—
3 or 5*	CSCP <sup>2</sup> /R	CSCP <sup>2</sup> /R	CSCP <sup>2</sup> /R	—	—	(CSCR)**
4	CSCP/R	CSCP/R	CSCP/R	CSCP/R	—	(CSCP <sup>2</sup> )**
5	CSCP/R	CSCP/R	CSCP/R	CSCP <sup>2</sup> /R**	CSCP	—
5	CSCP <sup>2</sup> /R <sup>4</sup>	CSCP	CSCP	CSCP	CSCP	—
5	CSCP	CSCP/R <sup>2</sup> *	CSCP	CSCP/R <sup>2</sup> *	CSCP	(CSCP)**

\* TASK-ORGANIZED CSC ELEMENTS SUPPORTS MORE THAN ONE DIVISION.

\*\* MEDICAL COMPANY, CSC HEADQUARTERS DETAILS THESE TO THE TASK-ORGANIZED CSC ELEMENTS WITH GREATER NEED AT A SPECIFIC TIME.

<sup>2,3,4</sup> NUMBERS INDICATE NUMBER OF MODULAR PREVENTIVE (P) OR RESTORATION (R) TEAMS.

**LEGEND:**

CSCP—combat stress control preventive team.

CSCR—combat stress control restoration team.

TOCSCE—task-organized combat stress control element.

**NOTE:** Medical company, CSC headquarters routinely shifts CSC teams or personnel from one task-organized CSC elements to another as work load in and behind each division fluctuates. It tries to keep at least a small task-organized CSC elements behind each division. It could, for instance, redistribute all of its CSC restoration section temporarily behind one division while keeping a CSCP dedicated to each of the other divisions.



restoration team is a clinical nurse specialist or if the psychologist is especially trained to prescribe medications. A CSC restoration team may be deployed forward without a CSC preventive team to support a heavily committed division or an ASMC in the corps.

c. *Reconditioning Centers.* The medical company, CSC will use task-organized CSC elements to staff separate, small reconditioning

centers behind each division. However, under some circumstances, the medical company, CSC may consolidate teams to establish a large reconditioning center which supports two or three divisions. Reconditioning facilities normally locate near a CSH. Figure 3-1 illustrates the task-organized CSC elements of the CSC medical company operating a reconditioning center near a CSH. For definitive information on reconditioning center operations, see Chapter 9.

**TASK-ORGANIZED CSC ELEMENTS OF THE MEDICAL COMPANY, CSC IN THE CORPS**

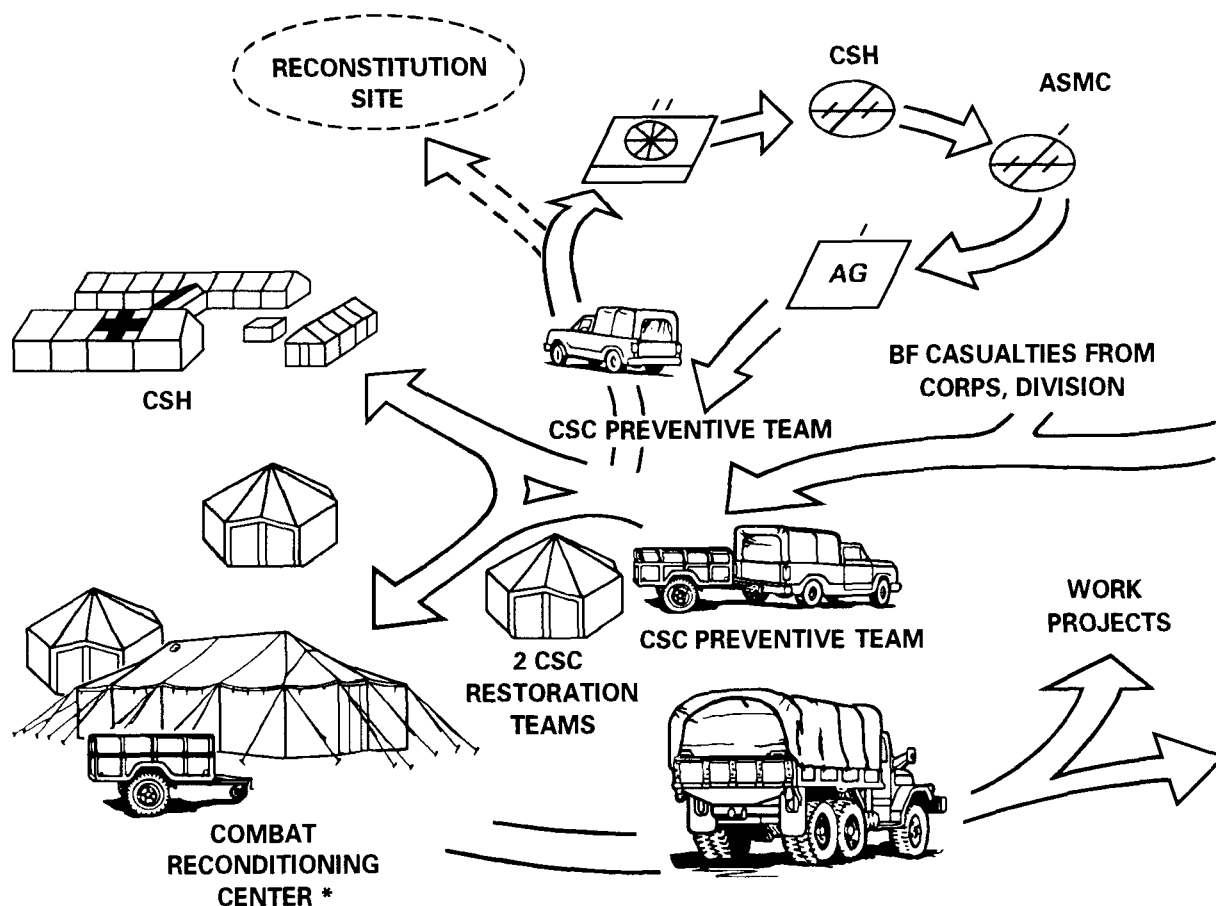

\* COMBAT RECONDITIONING CENTER WITH ATTACHED PATIENT-HOLDING PLATOON FROM MEDICAL COMPANY, HOLDING

Figure 3-1. Pictorial figure of a reconditioning center.

### 3-11. Medical Company, Combat Stress Control Coordination and Interface Requirements

The medical company, CSC coordinates with its higher medical headquarters element and with the units to which the company's CSC elements will be attached. The higher headquarters may be the medical brigade or medical group. Interface and coordination are essential for providing and ensuring CSC support requirements to prevent or limit the effects of combat stress and the number of BF casualties are accomplished.

a. *Coordination and Interface between the Medical Company and Its Higher Headquarters.* The medical company, CSC coordinates with its higher headquarters pertaining to its assigned mission. The mental health staff section of the medical brigade and medical group are points of contact for this coordination. It provides estimates and has input to the OPLANs. The company receives its OPODs from the higher headquarters. Interface between the company and the staff of its higher headquarters will focus on providing CSC, which includes preventive activities and operating restoration and reconditioning centers for the support divisions. This interface between the company and higher headquarters staff elements will include the following subject areas:

- Combat stress control operations.
- Assignment or attachment of the CSC preventive teams, CSC restoration teams, or task-organized CSC elements from the company.
- Daily personnel and equipment status reports.
- Class VIII status and resupply requirements.

- Casualty feeder reports.
- Work load summaries including consultation and triage activities, restoration or reconditioning center censuses, and special reconstitution support activities.
- Operation plans and orders
- Personnel replacement for the detachment.
- Medical intelligence information.
- Status of restoration center(s).
- Status of reconditioning center(s).
- Mental health/CSC consultation.
- Maintenance requirements and requests.
- Replacement and reconstitution operations.
- Civil-military operations.
- Host-nation support.
- Communications (S01, access to message center and nets, and transmission of CSC messages through medical and other channels).
- Mass casualty plan.
- Road movement clearances.
- Tactical updates.
- Contingency operations.

- Return-to-duty and nonreturn-to-duty procedures.

- Medical evacuation procedures (air and ground ambulances).

- Locations of supported units or changes in their location.

*b. Interface and Coordination with the Unit that has Operational Control of the Medical Company, Combat Stress Control Teams or Task-Organized Combat Stress Control Elements.* The headquarters of the unit with OPCON is responsible for providing the administrative and logistical support requirements of the company's teams or task-organized CSC elements. These requirements are normally identified in the attachment order. If not identified in the attachment order, they must be coordinated by the medical company, CSC headquarters prior to the deployment of its elements. Deployed teams or task-organized CSC elements from the medical company, CSC coordinate daily with the headquarters staff and section leaders (if required) of the unit to which they are attached. That headquarters transmits the CSC element's messages and reports to the receiving medical headquarters via medical C2 channels. The team/task-organized CSC elements' leader shares information with team members and updates the medical company, CSC commander as required. The medical company, CSC elements are provided daily updates from the headquarters element of the unit to whom attached. These daily updates may include information pertaining to:

- Threat situation.
- Tactical situation.
- Patient/BF casualty status.

- Changes in CHS requirements.

Coordination activities and exchange of subject area information should include—

- Command and control procedures.

- Status of F'SMCs and CSC preventive teams.

- Communications.

- Operational support requirements.

- Civil-military operations.

- Restoration operations.

- Reinforcement and reconstitution.

- Reconditioning center operations.

- Maintenance.

- Personnel replacement.

- Road movement and clearances.

- Casualty reporting and accountability.

- Patient-holding procedures.

- Nuclear, biological, and chemical defensive operations.

- Hospital admission and disposition procedures.

## CHAPTER 4

## COMBAT STRESS CONTROL CONSULTATION

## 4-1. Priorities and General Principles

a. *Primary Emphasis of Combat Stress Control.* The primary emphasis of CSC is on the enhancement of positive, mission-oriented motivation and the prevention of stress-related casualties. Combat stress control personnel provide consultation and training (either formal or informal) on many topics including—

- Enhancement of unit cohesion, leadership, and readiness.
- Risk factors (stressors).
- Recognition signs of stress symptoms and behaviors.
- Leaders' actions to control stressors and stress.
- Individual stress management techniques and skills.

b. *Combat Stress Prevention.* Combat stress prevention programs reduce the incidence of new combat stress-related casualties. These programs promote the early recovery and RTD of stress casualties. They reduce the cases which could otherwise overload the CHS system. Overall, combat stress prevention programs are significant combat multipliers which enhance the Army's fighting strength and its ability to perform its mission while significantly reducing the number of casualties.

## NOTE

Overall, consultation has the highest priority among the CSC functions.

If consultation is deferred due to tactical or other critical situations, consultation services should be

reinstated at the earliest possible time. If not quickly reinstated, other functions could soon be overwhelmed by the casualty caseload.

(1) *Army operations during war.* During war, the primary efforts are toward the prevention of and successful RTD of BF casualties. Historically, BF casualties have represented from one-sixth to one-third of all battle casualties in high-intensity wars. Failure to reduce/prevent BF casualties or RTD a large numbers of these cases could affect the outcome of key battles. The fast pace of the high-technology battle requires that CSC preventive consultation be ongoing before the fighting starts.

(2) *Operations other than war.* In conflict and peacetime contingency operations, CSC consultation activities are more focused toward prevention of misconduct stress behaviors and on maintaining unit cohesion, morale, and esprit de corps than on preventing BF casualties. This is done because BF casualties are rarely seen in OOTW, but the reported incidence of misconduct stress behaviors are relatively frequent. The enemy in OOTW may deliberately use stress to try to provoke our soldiers to commit misconduct. Misconduct, especially commission of atrocities, not only endangers mission accomplishment but can severely damage US or allied national interests.

(3) *All intensities of conflict.* Psychologically, traumatic and catastrophic events occur in war and OOTW. Combat stress control personnel must be prepared to provide CSC intervention. Combat stress control preventive programs and CSC intervention for catastrophic events will assist in protecting soldiers from PTSDs.

c. *Modes of Combat Stress Control Consultation.* Combat stress control consultation is defined as providing expert advice, education,

training, and planning assistance. The objectives of consultation are the improvement of psychological readiness and the prevention and treatment of BF, misconduct stress behaviors, PTSDs, and all stress-related problems. This consultation support is provided to commanders, leaders, and the staff and medical personnel of supported units. Consultation on all topics related to the prevention, treatment, and RTD (or other disposition) of BF casualties, misconduct stress behaviors, PTSDs, and NP disorders is provided.

(1) Combat stress control personnel are the primary resource for advice and training on ways to control stressors and stress. Supporting CSC personnel interface with—

- Unit commanders.
- Staff elements.
- Leaders.
- Chaplains (very important contact).
- Medical personnel (other than mental health/CSC personnel).
- Other personnel.

Leaders at all levels must be made aware that CSC measures can reduce BF casualties to fewer than one per ten WIA and can expedite the early return of BF casualties to full duty (see FM 22-51). These measures also help in reducing problem behaviors and incidents which detract from the overall readiness of a unit. Some of these detractors include—

- Substance abuse.
- Suicides.
- Home front problems.

- Misconduct.
- Other stress disorders.

(2) Consultation may be provided in response to a specific request or be initiated by mental health personnel. Methods for providing consultation and training include—

- One-on-one.
- Small discussion group.
- Large groups.

Consultation is an ongoing process which is performed in both peacetime and wartime. It is conducted before, during, and after combat.

(3) Consultation is best initiated through face-to-face contact, preferably at the supported unit's location. Telephone and radio may be used to set up further sessions or to provide follow-up consultation. Audio tapes and videotapes may also be used if the unit or meeting site has the equipment to play them. Follow-up consultations also works best when the face-to-face contact method is used.

(4) Successful consultation is dependent on trust and the familiarity established between the consultant and the soldier(s) with whom he is working. Especially in a hierarchical, high-stress, time-pressured setting like the Army, the consultant must possess a credible military bearing. He should have a thorough knowledge of the military (the units, missions, vocabulary, acronyms, and skills involved). He must be realistic and self-confident about the accomplishment of his work. In some instances, sufficient rank may also be necessary. These visible military features are often more important in establishing credibility than are academic or clinical credentials. In a peacetime environment, academic and clinical credentials are important for long-term credibility.

(5) Therefore, when possible, the consultant should establish contact and rapport with the personnel of supported units long before action becomes imminent. In general, the longer the relationship is established prior to the onset of tactical operations, the greater the effectiveness of the consultation.

*d. Consultants.* All mental health/CSC professional disciplines and enlisted MOSS may serve as consultants in mental health/CSC areas.

(1) There are five disciplines in the mental health/CSC area and each one has specific subject areas. These disciplines include—

- Psychiatry.
- Psychiatric nursing.
- Clinical psychology.
- Social work.
- Occupational therapy.

Consultants will naturally rely and focus on their specific specialty. Each of the disciplines should also be able to provide routine consultation for all basic topics. Therefore, it is essential that information be shared ongoing among the five mental health disciplines and between officers and their enlisted assistants. This mutual understanding also expedites the appropriate referral to the relevant specialist, as required.

(2) Experience shows that the CSC consultation mission (and to a lesser extent, the treatment mission) is functionally divided into professional mental health-credentialed officer responsibilities and experienced mental health NCO responsibilities. Since each has a unique role, neither officer nor NCO can do the other's business with full effectiveness. The solution is to form cohesive officer/NCO teams. The officer

and especially the NCOs must have sufficient rank and experience to establish face-to-face validity as advisors and counselors to line officers and senior NCOs. Similarly, each mental health discipline (psychiatry, clinical psychology, social work, psychiatric nursing, and OT) has areas of unique professional expertise. A multidisciplinary approach is required which provides mutual access to each discipline at key levels in the CSC unit organization. There must also be sharing of information within the CSC units to increase the areas of shared expertise.

(3) Other personnel will be involved in recognition and control of stress as a result of their position or duty assignments. Consultation and training to develop them into effective CSC consultants is a high priority for mental health/CSC personnel. These personnel will include—

- Unit leaders.
- Chaplains and chaplains' assistants.
- Other physicians and physician assistants.
- Combat medics.
- Other supporting medical personnel.

#### NOTE

The role of a good consultant is to train others to use his knowledge rather than to guard his information as a trade secret.

*e. Audience for Consultation.* The target audiences for consultation vary, depending

on location and mission. Consultation and training activities should be identified, prioritized, and scheduled to achieve maximum participation from all supported units. Depending on the units in the area of support, broad types or categories of personnel are considered for consultation activities. These personnel may include—

- The command or unit surgeon and his staff.
- Staff chaplain and unit ministry team.
- The senior commander and the senior NCO (of the unit or the command sergeants major of the corps, division, brigade, and/or battalion).
- Staff officers and NCOs, including adjutant and personnel (S1/G1), intelligence (S2/G2), operations (S3/G3), logistics (S4/G4), civil affairs (G5), DMOCS, and the judge advocate general (JAG).
- Company-grade leaders, especially company commanders, executive officers, first sergeants, platoon leaders, and platoon sergeants.
- Assembled troops of combat, CS, and CSS units.
- Medical personnel including physicians, physician assistants, dentists, nurses, practical nurses, medical specialists and NCOs, and the nursing services of CZ and COMMZ hospitals.

Some of these medical personnel may be recent additions to their units who are likely to be from the Professional Filler System (PROFIS) or Individual Ready Reserve. Such individuals may have special need for quick education in CSC principles.

**NOTE**

A critical issue is to ensure that medical personnel do not overdiagnose stress casualties.

Stress cases should not be diagnosed as NP or physical disability cases. Stress cases should not be prematurely evacuated out of the theater without adequate trial of the CSC restoration and reconditioning program.

**4-2. Consultant Activities During Pre-deployment and During Buildup and Waiting Phases in the Theater of Operations**

*a. Knowledge of the Supported Units.*

The mental health/CSC personnel should train in the field with the units they will support during combat. They must become knowledgeable of these units and familiar with their personnel. Through contact with supported units and involvement in training activities, mental health/CSC personnel gain the trust and confidence of those personnel. The trust, confidence, and familiarity of unit personnel will significantly enhance mental health/CSC personnel's ability to perform their mission. All available time during pre-deployment and build up in the TO should be utilized to gain familiarity with any new units. Mental health/CSC personnel must also make an effort to maintain relationships already established through training. Some of the information provided below pertains to establishing relationships with the new unit and may apply to maintaining relationships.

- (1) Present a briefing on the mental health/CSC mission and its relevance at commander calls, officer/NCO professional development sessions, and as part of the combat orientation of new replacement units arriving in the TO.

(2) Arrange to visit unit leaders and work areas. Choose times when they can explain and demonstrate their mission. Participate as an observer at the crew and team level in maneuver or live fire training exercises. Emphasize that the purpose of the visit involves the mental health/CSC mission to support them during combat. Explain to them that the mental health/CSC mission requires that mental health/CSC personnel be knowledgeable of what they do; that the mental health/CSC personnel need to be aware of stressful conditions associated with their mission.

(3) Attend ceremonies of supported units and participate in their unit activities such as physical training.

(4) Provide briefings, classes, information papers, and more importantly practical exercises in topics which are relevant to the mission scenario. Topics should include—

- Combat stress/BF recognition and management (appropriate for the branch, rank, and duties of the audience).
- Techniques for building unit cohesion.
- Performing stress management and relaxation techniques.
- Maintaining performance in continuous and sustained operations.
- Ensuring psychological preparation for NBC defense.
- Preventing BF and misconduct stress behaviors by defending against the stresses of terrorism, guerrilla operations and restrictive rules of engagement.

- Treating EPWs according to the provisions of the Geneva Conventions.

- Orienting soldiers to the customs, traditions, religion, and other socio-economic values of the civilian population.

- Recognizing the overstressed soldier.

- Recognizing signs of substance abuse and preventing, treating, and rehabilitating abusers.

- Improving leadership skills for interviewing, counseling, and assisting problem soldiers.

- Developing leadership skills to conduct after-action debriefings (routinely and for serious accidents, or combat situations).

- Conducting grief management (the chaplain should be included).

- Improving time management, organizational skills, and leisure time skills.

- Controlling family issues, including how to access supporting agencies such as—

- Red Cross.
- Army Community Service.
- Army Emergency Relief.
- Exceptional Family Member Program.
- Family Advocacy Program.



- Medical care and the Civilian Health and Medical Programs of the Uniformed Services and Delta Dental Plan.

- Preparing families for deployment of the service member's unit.

**NOTE**

Time invested in consultation is never wasted. New knowledge, insight, and points of contact are always worth gaining. Just ask questions and listen.

*b. Conduct Unit Survey and Focus Interviews.* Interview 8 to 12 soldiers as a group and ask a series of general or structured questions. Survey interviews use open-ended questions and seek answers to a wide range of issues. Focus interviews use more direct questions to answer a specific issue; for example, the adequacy of the unit's sleep plan. In both types of interviews, the responses are recorded and trends are identified. These interviews can be done in the field as battlefield interviews and can be used to debrief and to gather data. Collected data is then used as a basis to train or provide consultation.

*c. Administer Survey Instruments (Questionnaires).* Survey questionnaires are normally used in conjunction with briefings, focused interviews, classes, or field exercises. They are used to assess unit cohesion, confidence, readiness for combat, and familiarity with stress control, or to identify areas which need further training or command attention. Surveys may also be conducted to answer specific command questions about unit morale and readiness. Survey results and recommendations are provided to unit leaders.

(1) Such surveys work best when they are endorsed (and perhaps mandated) by higher command, but are advertised and implemented as an aid to the junior leaders, not a pass-fail test.

(2) Results should be shared with the junior leaders first and should be worded in positive terms: "Here is what looks good, here is what needs more work, and here are some ideas (not orders) for how to do it."

(3) The questionnaire should be administered in a way that guarantees anonymity to the responders: It is best to administer it all at one time and to have it handed out and collected by the mental health/CSC surveyors, not the unit leaders.

(4) Questionnaires need to be brief, simple, unambiguous, and easily hand- or machine-scored to provide quick feedback. Standardized, well-documented survey instruments are best. Sharpened pencils and firm writing surfaces must be supplied. Shelter from adverse weather (or water-resistant questionnaire sheets) may be necessary when surveys are conducted in the field.

**NOTE**

Survey instruments which are currently being used include Department of the Army Pamphlet (DA PAM) 600-69. Currently under development and testing by Walter Reed Army Institute of Research is another survey titled "Psychological Readiness for Combat Survey" (see Appendix B).

*d. Monitor Stress Risk Factors (Stressors) and Indicators of Stress in Units.* Information about stressors and stress in a unit may be obtained by coordinating with various sources. These sources of information include—

- S1/G1, S2/G2, S3/G3 staffs, commanders, command sergeants major and first sergeants,
- Military police blotter reports.

- Unit surgeons.
- Preventive medicine (PVNTMED) reports and personnel.
- Chaplains.
- Judge advocate general.

### NOTE

Information obtained from the above sources involves the statistical implications without violation of AR 340-21, The Army Privacy Act Program.

Stress on the home front may be monitored by the unit's rear detachment, keeping in touch with the post's Deputy for Personnel and Civilian Affairs (DPCA) and various medical department activity (MEDDAC) mental health and patient care services.

(1) Monitor known stressors such as—

- Number of days/months
- Substandard living conditions.
- Social isolation from surroundings due to distance, climate, foreign culture, and hostile locals.
- Inspector general (IG) or very important person visitor.
- Insufficient facilities or funds for mission training or morale/welfare/recreation support.

- Commission of terrorism or atrocities by the enemy.
- Likelihood of temptations for substance abuse.
- Recent losses and/or new replacements in the unit.
- Change in leadership.

(2) Monitor indices of excessive stress in units. Mental health/CSC personnel monitor known warning signs of excessive stress to identify units which need special consultation. Some of these warning signs are—

- Many disciplinary actions in a unit.
- High absent without leave (AWOL) rates.
- Inspector general complaints.
- Increased requests for transfers.
- Alcohol or drug intoxication and driving while intoxicated charges.
- High sick call rates.
- Preventable diseases (sexual misbehavior).
- Fights, minor injuries, and self-inflicted wounds.
- Suicide gestures/attempts/completions.
- Homicide threats, attempts, and completions.

(3) Monitor home front (rear detachment) indices of excessive stress, such as—

- Spouse and child abuse.
- Bad checks.
- High numbers of separations and divorces.
- Significant numbers of couples in counseling.
- Family members caught shoplifting or an involvement in other crimes or misdemeanors.
- Financial problems.

*e. Conduct Transition (Change of Command) Workshops.* Mental health/CSC personnel conduct transition (change of command) workshops for supported units. These workshops are normally requested by the incoming commander. The primary purpose of these workshops is to—

- Facilitate staff discussion of what the staff sees as the unit's (and staffs) strong points and the areas needing more work.
- Provide the new commander the opportunity to discuss his leadership style and his expectations and set priorities for the staff.

*f. Conduct Personal Reliability Screening.* Personal reliability screening is required by AR 40-501, or it may be command directed.

*g. Supporting and Assisting Alcohol and Drug Prevention and Control Programs.* In the TO, there are no formal alcohol or drug support groups. Therefore, mental health/CSC personnel promote the establishment of ad hoc alcoholic support groups or other support groups. They evaluate cases of alcohol/drug abuse and

recommend rehabilitation, medical treatment, or administrative disposition.

#### 4-3. **Combat Stress Control Consultant Activities for Staff and Operational Planning**

*a. Planning.* It is important that CSC personnel be involved in the overall planning process. Combat stress control personnel provide advice and assistance to commanders and staff on CSC issues. These issues may include—

- Providing measures for monitoring and controlling stressors.
- Providing stress casualty estimates.
- Providing CSC input for reconstitution support.
- Conducting CSC preventive operations.
- Deploying CSC assets forward to provide immediate restoration support.
- Establishing procedures for CSC reconditioning, including resource and coordination requirements.
- Establishing procedures with supporting battalion S1s for transporting BF casualties who are able to RTD to their units.
- Providing input on using mental health/CSC asset for supporting host-nation or humanitarian civil assistance operations.

(1) Combat stress control personnel provide the command surgeon input for inclusion in the CHS estimate and plan. Combat stress control personnel are included early in the

mission planning process to ensure adequate CSC resources are included in the CHS plan.

(2) To enhance the performance of CSC personnel in the decision-making and planning process, they should be provided realistic training. This training can include participation in activities such as field training and CP exercises. Additionally, mental health/CSC personnel must be given the opportunity to learn, practice, and perfect their skills for providing unit consultation and the other five functional mission areas associated with CSC and mental health. This is accomplished through their participation in various training exercises.

*b. Combat Stress Control Staff Planning in Combat.* The CSC consultant must assure that staff planners keep in mind that CSC must be proactive and rapidly reactive.

(1) *Proactive measures.* Proactive measures include the pre-positioning of CSC personnel to the maximum extent possible to support those units that are most likely to experience combat actions. This will change from day to day. In order to anticipate and prioritize, the planner should also evaluate the likelihood that the combat action will involve the special risk factors for BF casualties and misconduct stress behaviors (see Appendix B). Pre-positioning may include—

- Deploying organic CSC personnel far forward to areas of need.
- Sending CSC personnel to an AXP behind the battalion entering combat.
- Sending CSC personnel to a BAS in the combat trains,
- Sending additional organic CSC personnel to the BSA with the supporting FSMC.

- Attaching corp-level CSC teams base on casualty estimates to the supporting medical company in the BSA, DSA, or corps area.

- Providing warning orders to backup CSC teams in the division rear or corps area.

The warning orders alert CSC teams to prepare to deploy forward or to detach personnel to reinforce the teams already forward. This forewarning is especially important if the backup teams need to reduce their ongoing treatment caseload.

(2) *Rapid reaction.* For rapid reaction, CSC personnel and teams require staff actions to identify where they need to move once the actions have started. The staff must also coordinate this move. Certain events should be recognized and reacted to when they occur. These events include—

- Having high numbers of WIAs and stress casualties at a location which was not anticipated or covered by CSC resources.
- Receiving reports that a unit has experienced an especially traumatic incident (such as casualties from friendly fire).

It would be helpful for CSC personnel to participate in the unit's after-action debriefing (see subsequent paragraphs and after-action debriefing in Chapter 5). Definitive information on CHS planning is found in Appendix B and in FMs 8-10, 8-10-5, 8-42, and 8-55.

#### 4-4. Consultation During Mobilization and Deployment

*a. Planning and Consultation Activities.* During mobilization, contingency plans are reviewed and updated, as required, Combat stress

control elements provide any revised information to the command surgeon for inclusion in CHS estimates and plan. In addition to mobilizing their own assets, CSC elements will initiate consultant functions immediately. All command and staff briefings should have a CSC representative present to ensure CSC personnel are aware of developing situations. Supported units are informed as necessary on changes/updates to the CSC operating procedures.

*b. Coordination with Supported Units.*

All supported units are contacted by CSC personnel to confirm preestablished points of contact (POCs) or to identify new POCs. Coordination visits to newly supported units must be brief to ensure they do not hamper the unit's mobilization process. Only essential information pertaining to CSC consultation and support should be discussed. Liaison consultants can also gain valuable information and insight about the unit by listening and observing without being in the way.

*c. Home Station Support.*

During mobilization, the disruption of the family, finances, and other personal matters can adversely affect the morale of the deploying soldier. It is important, therefore, to facilitate the transition from home station to the deployment area. Combat stress control personnel should—

- Remind commanders and leaders of the importance of these issues.
- Work toward greater participation of family members in established family support groups.
- Assist with the activation of family support groups and coordinate home station command support when possible.
- Ensure commanders provide the locations of established family assistance centers to family members.

**4-5. Consultation Support During Combat**

*a. Establishment.* The CSC consultant (or team or unit) needs a secure base camp from which to operate. Small consultation teams may be able to integrate themselves into the quarters of the supporting unit. Large CSC teams will provide their own shelter. Combat stress control teams are usually either assigned or attached to medical units for support.

(1) Depending on the echelon, the supporting medical unit may be an FSMC (in the BSA), an MSMC (in the DSA), or an ASMC (operating within a base cluster in the corps and COMMZ). Combat stress control teams or units may also collocate with a CSH, FH, GH, or a medical headquarters unit (ASMB, medical group, medical brigade, MEDCOM). Combat stress control personnel with primary consultation missions are organic to the above hospital and medical headquarters. In other cases, the CSC personnel are attached to the medical unit for support, either as individuals or as teams composed of 1 to 15 or more personnel.

(2) Attachment of CSC elements must be coordinated with the supporting medical unit by the headquarters issuing the attachment order. Coordination must include provision for quarters, food, and fuel. After attachment, the command surgeon will brief the CSC element on the threat, SOI procedures, and other pertinent information as required by the situation.

*b. Continuation of Consultation and Training Activities.* During combat, consultation and training activities are continued. These activities may be curtailed or suspended as a result of the tactical situation but are continued as soon as the situation permits. The consultant coordinates with the command surgeon on CSC information to be presented to the commander. If possible, the CSC personnel accompany the command surgeon when this information is briefed.

It is important that senior commanders and staff are briefed on the CSC operation. When the senior leadership understands the importance of CSC consultation and prevention programs, maximum participation within the command is achievable.

(1) Movement outside of secure areas such as BSAs, DSAs, or base clusters will be restricted. Any movement outside of secure areas involves increased risk and requires prior coordination. The increased threat brought on by combat requires that all CSC personnel be proficient in performing their common soldier skills. Any CSC support mission requiring ground movement outside the secure area must be coordinated and approved. This coordination is accomplished with either the tactical operations center (TOC) or base cluster operations center. In most cases, preferred movement outside a secure area is done by convoy and has MP or other security elements. Some main supply routes (MSRs) may be considered secure during daylight hours after they have been cleared by security forces. In other situations, CSC personnel may follow returning ground ambulances to their destination. In all cases, CSC personnel must have approval prior to departing any secure area.

(2) Priority for CSC consultation during combat focuses on those areas with greatest, immediate potential to conserve fighting strength. These areas include—

- Implementing the CSC support plan.
- Assisting units with resting of DUTY and REST category BF cases in their units when possible.
- Advising and assisting with medical triage to prevent unnecessary evacuation of BF cases.

- Facilitating RTD and reintegration of recovered cases into units by coordinating with patient administration, the S1/GI, and directly with soldiers' unit leaders, chaplains, and medics,

c. *Staff Planning.* Staff planning is conducted in coordination with the unit surgeons (medical company commander). As new operations or changes in the tactical situation evolve, estimates and plans must be reviewed and updated as required.

d. *Periodic Visits to Supported Units.* The CSC consultant conducts periodic visits to supported units. These visits should occur on a predictable, recurring basis. The objective is simply to maintain contact and find out what is really happening. Once the pattern is established, field phones or radio contact can fill the gaps when visits are impractical.

(1) It is essential that the consultant (or consultant officer/NCO team) establish a communications network so that he can be contacted quickly anywhere in the course of making rounds. If the consultant does not have a radio, it is important that he keep the supporting medical unit headquarters informed of his location and schedule. This is accomplished by passing a message through the supporting unit headquarters. The consultant uses brevity code messages (in accordance with TSOPs) which can be transmitted quickly by host-unit signal personnel. If the schedule changes, he informs the supporting medical unit of the change.

(2) Visiting supported units in the immediate vicinity (within the BSA, DSA, or base cluster) is accomplished on a daily basis when REST BF cases are being held in their unit areas for light duty or rest. In most instances, the units visited will be headquarters and headquarters companies (HHCs) or CSS units. It is required that CSC personnel know the location of all BF cases and monitor their status on a daily basis.

(3) Each consultant when visiting a unit first makes contact with the previously identified POCs. If the consultant team includes an officer and an NCO, they naturally divide the people to be talked with according to officer/NCO status and rank. The consultant speaks with the junior leaders who have BF casualties in their sections. If advice or assistance is needed, this facilitates the identification of problem areas. He speaks with the BF casualties as necessary to monitor their progress. These “work-ups” are brief and factual, with only sufficient items recorded in the consultants notebook to remind the CSC provider of important details. These consultation cases are “carded for record only” on DD Form 1380. (For additional use of DD Form 1380, refer to AR 40-66 and FMs 8-10-6 and 8-230.)

(4) The consultant advises unit leaders on the care and handling of BF casualties. Potential subject areas will include how to—

- Talk with soldiers experiencing BF.
- Provide reassurance.
- Ensure rest/sleep requirements are met.
- Provide adequate nourishment and fluid replenishment.
- Practice personal hygiene.
- Conduct work activities.
- Provide recreation (if possible).
- Initiate after-action debriefings.

(5) When BF casualties appear unmanageable, they are not held in their unit

area. The consultant should advise unit medical personnel or the commander to send any BF casualties judged to be at risk of serious medical/emotional illness to the supporting MTF for NP evaluation. At the supporting MTF, the BF casualty receives further NP triage, stabilization, restoration, or evacuation.

*e. Initial Evaluation at a Medical Treatment Facility.* At the MTF, REST, HOLD, or REFER BF cases are evaluated by general medical personnel (for example, at the clearing station). This evaluation may include advice and an interview by the CSC consultant, when present. If the CSC person is a psychiatrist, he may elect to perform the examination and triage of the BF casualty.

(1) Battle fatigue cases that require medical observation and treatment are managed as discussed in Chapters 8 and Chapter 9.

(2) Battle fatigue cases judged able to RTD to their unit areas include those soldiers—

- Treated and returned to duty immediately (category DUTY).
- Placed on limited or light duty for 1 to 3 days of rest under the control of the soldier’s own battalion HHC or the brigade S1 (category REST).
- Given light duties.

**NOTE**

Maneuver units positioned in forward areas only have those personnel who are fit for full duty. Limited or light duty is nonexistent in these units. If BF cases are sent directly to these units, they must be able to perform full duties for their own and the unit’s safety.

If limited or light duty cases (REST category) are members of maneuver units operating in forward areas, alternative units are used. Alternative units may include the battalion's HHC which is positioned with the field trains. Under some circumstances, CSS units (such as a headquarters and headquarters detachment [HHD], maintenance, or supply company of the FSB) may be used temporarily for REST BF casualties. Alternative units out of the BF casualty's organizational structure are not usually preferred, as the individual soldier does not have any social, emotional, or administrative ties with the unit.

(3) Transportation of BF cases returning to their units from the supporting medical company may require coordination. The patient administration specialist of the medical company may be required to contact the brigade S1 of the soldier's unit and request the unit provide transportation. In other instances, transportation for the BF cases back to their unit may be coordinated through the support operations section, movement control officer, or the TOC. These sections can identify any vehicles going to the soldier's unit area. The use of ambulances or medical vehicles (such as the CSC vehicle) to transport soldiers back to their unit is not permitted under the Geneva Conventions (see Appendix D). The transporting of soldiers to their unit area could cause a loss of protected status for those medical personnel involved. For additional information pertaining to the Geneva Conventions, see Appendix D.

*f. Monitoring the Progress of REST Battle Fatigue Cases.* As previously discussed the progress of soldiers returned to or held in their unit for rest or light duty is monitored by the CSC consultant.

(1) When those soldiers being held in temporary units for quarters, rest, or light duty are ready to return to the original duty unit, the

headquarters element of the temporary unit coordinates for transportation. Logistical vehicles supporting forward areas are the most likely means for returning soldiers to their units.

(2) Combat stress control personnel may be required to enter forward areas to provide special reintegrating instructions for a BF casualty that is returning to duty. Commonly, a brief note or oral instructions provided to the soldier or the unit leader are the methods used to get instructions to unit commanders and first sergeants. Special instructions may also be sent forward via the chaplain/unit ministry team or ambulance drivers relaying instruction to the BAS. These instructions will assist medics and unit leaders on how to maximize successful reintegration of the recovered soldier.

*g. Reevaluation of REST Battle Fatigue Cases Who Do Not Improve.* Soldiers who fail to improve sufficiently to return to their original duties and unit in several days must be reevaluated. During this evaluation, the CSC consultant attempts to rule out malingering, situations with too much "secondary gain," or other physical and mental disorders (see the combat NP triage functions, Chapter 6).

(1) Advising the supervisors to increase positive expectation, reduce the comfort of the facility (the secondary gain), and/or having the first sergeant or other members of the unit visit the soldier may be sufficient to achieve full RTD.

(2) A few cases may be recommended for reassignment to CSS jobs in the same battalion. However, this must be kept to a minimum so as not to undermine positive expectation of full recovery and lead to resentment or imitation by other soldiers. If job reclassification and reassignment is judged necessary, it will usually be to another unit.



(3) Cases of REST BF who fail to respond after 1 to 3 days of rest are reevaluated. Based on the reevaluation, these BF cases are either held for restoration treatment at the supporting MTF or evacuated one echelon for more intensive restoration or reconditioning treatment (see Chapters 8 and 9).

*h. Debriefings.* Combat stress control consultation following potentially traumatic events involves three types of debriefings. The three types of debriefings are—

- After-action debriefings.
- Large group debriefings.
- Critical event debriefings.

(1) After-action debriefings should be conducted by all leaders of small units after all operations. After-action debriefings are especially important after a difficult action. The leader(s) extend the lessons learned orientation of the standard after-action review (AAR) to include sharing and recognizing the feelings, emotions, and thoughts of team members. (See Chapter 5 for after-action debriefings.)

(2) Large group debriefing may be an expedient method when small group debriefings are impractical. Alternatively, the large group debriefing may be the culmination of the after-action debriefing or critical event debriefing of the component squads, platoons, or small groups. The leader may be either the unit's leader or a facilitator from outside the unit. Since everyone cannot be encouraged to take an active part, the leader encourages representatives of the formal or informal subgroups to review their subgroup's actions and experiences. Expressions of feelings are again encouraged, respected, and validated. Individuals who were not specifically asked to speak are encouraged to speak up if they feel there is more that needs to be said. Information by the

leader about the normal stress process and reactions may have to take the place of the sharing of personal experiences.

(3) Critical event debriefings are reserved for exceptionally traumatic events. They are lead by trained critical event debriefers, usually in teams of two to four persons. The teams are led by CSC personnel but may include trained chaplains, medical personnel, and line officers and NCOs. The participants in the critical event debriefing may be members of the same unit; they may include strangers thrown together by chance by a highly traumatic event (for example, members of a unit responsible for a "friendly fire" incident).

(4) After-action, large group, and critical event debriefings share common features but differ from each others in significant ways. Each type of debriefings is preferred for a particular situation, but a combination of these debriefings may be used for some situations. The CSC consultant should be prepared to—

- Teach other personnel how to lead or facilitate the above debriefings.
- Facilitate each type.
- Lead or conduct each type.
- Know when each is appropriate.

Combat stress control debriefings are described in Chapter 5.

#### **4-6. Consultation to Medical Treatment Facilities**

*a. Providing Consultation to Medical Treatment Facilities.* Consultation for hospital and Echelon II MTF staffs is provided by organic.

attached, or collocated CSC units or elements. Hospital neuropsychiatry staffs provide consultation primarily to hospital staffs but also advise MTFs and nonmedical units operating within their area of support. Consultation assistance may include—

- Evaluating newly arrived cases to rule out BF or NP disorders or triaging for possible admission or retention and disposition.
- Evaluating cases already on the wards or in a holding section with medical/surgical diagnoses that include BF or NP disorders.
- Providing consultation and training for medical staff on combat stress prevention and methods of controlling stressors.

#### NOTE

Stress reaction in medical personnel is often denied or overlooked. Thus, the consultant's efforts may have to be active during consultation to medical personnel.

*b. Evaluating and Triaging New Patients.* The majority of these patients will be seen in triage or the emergency medical treatment area of a hospital or medical company. When providing CSC training to personnel working in these areas, the consultant should—

(1) Emphasize the importance of giving immediate reassurance to the unwounded BF (stress) cases and moving them away immediately from the surgical holding or emergency medical treatment areas.

(2) Emphasize that even those cases who cannot be returned to their units

quickly and must be held temporarily “for rest” are not being “admitted” or “hospitalized,” (their medical records may show that they technically are admissions).

(3) Coordinate and organize a non-patient area for placement of these cases. Life support and administrative support is provided by the MTF. Nonmedical personnel may be used to staff this area and provide supervision for cases in a nonpatient status. The selected area should be quiet and away from high traffic areas. A relatively quiet area will afford these cases the opportunity to rest and sleep. Personnel that are providing supervision for these cases should be briefed on handling and caring for these soldiers. It is important that these soldiers be provided the opportunity to talk about what has happened to them. It is also important that these soldiers be given useful light duties which reaffirm their nonpatient status.

(4) Monitor the progress of all cases and determine their disposition in accordance with corps and theater evacuation policies. These cases are either returned to their unit after sufficient time of rest (1 to 3 days) as DUTY or REST BF casualties, or they are transferred to an MTF established for restoration or reconditioning of BF casualties.

*c. Consultation for Medical and Surgical Patients with Neuropsychiatric Conditions.* Neuropsychiatric personnel may be requested to evaluate medical and surgical patients who are being held at MTFs. These medical and surgical patients when suffering NP disorders can be divided roughly into five overlapping groups.

(1) Organic mental disorders which may include conditions such as—

- Disruptive confusion.
- Disorientation.

- Hallucinations and agitation after high fever, or metabolic disruption of brain functions.
- Amnesia and poor impulse control following head injury.

The consultant recommends psychiatric treatment modalities (for example, drugs and restraints) and nursing measures which are compatible with the underlying diagnosis and treatment.

(2) Major psychiatric illness coincidental to a medical or surgical condition, or perhaps responsible for it, as in serious suicide attempts. The consultant recommends NP treatment which is compatible with the illness or injury and the treatments prescribed for it.

(3) Patients with ongoing or potential psychiatric reactions to their injuries or the circumstances of the trauma. Many soldiers experience initial relief and even euphoria on being wounded. They may feel a sense of relief because they are honorably out of action and in the care of the medics. They may sense this feeling of euphoria as a result of receiving morphine. Only later may the implications of a life of physical disability begin to depress them. Some of these patients may be willing and even desperate to tell the story of what happened. Other patients may exhibit signs of depression, hostility, agitation, or other behaviors as a reaction to their situation and injuries. Potential psychiatric reactions may occur in any patient, but soldiers with some types of wounds and injuries are considered to be at special risk. These wounds or injuries include—

- Genital wounds.
- Major amputations.
- Serious disfigurement.
- Blindness.

- Any condition that causes paralysis,

Empathic management by all health care providers is critical and can greatly facilitate rehabilitation and minimize PTSDs. This is important even if the patient appears to be unconscious.

(4) Patients with wounds that require hospitalization but will be returned to duty within the theater. Some of these patients have residual BF and reactions to the circumstances of trauma. A few of these patients experience anticipatory BF at the prospect of returning to combat. These patients should be placed in a minimal care area as soon as their condition permits and be provided treatment which is similar to that provided to BF cases.

(5) Soldiers reacting to home front problems unrelated to their combat duties or injuries. The consultant helps identify problems, provides guidance as appropriate, and mobilizes social service support agencies, if applicable.

*d. Providing Combat Stress Control Consultation to Medical Personnel.* Medical personnel are not immune to the increased stress associated with supporting combat operations. It is important that medical personnel are not overlooked and that CSC consultation support be provided to all MTFs, medical units, and medical elements in the theater.

(1) Neuropsychiatric and CSC consultation personnel advise the chain of command and supervisors about general measures to buffer the intense stressors associated with providing combat medical care. These stressors may include—

- Providing round-the-clock emergency care for severely injured patients.
- Facing the moral dilemma of placing patients in the surgical triage

“Expectant” category (these patients receive only supportive care as time permits).

- Facing the moral dilemma of saving the grossly, lamentably disabled when there is not a mass casualty situation and they do not have to be placed in the surgical “Expectant” category. This is even more difficult if the patient is asking to be euthanatized.

- Facing the moral dilemma of placing patients in the surgical “minimal” or RTD category. Those soldiers are expected to return to the horrors and dangers of combat; most medical personnel are not subjected to similar risk.

- Treating and providing care for wounded soldiers who are related or someone whom they know.

- Maintaining appropriate interpersonal relationships when everyone is under extreme stress.

- Knowing how to unwind during lulls in the action without slipping into misconduct stress behaviors.

- Dealing with the boredom when patient activities come to a halt for long periods of time.

(2) Combat stress control consultants’ recommendations for resolving or reducing those stressors identified above include—

- Establishing a sleep plan and shift schedules.

- Developing time-management skills.

- Building team and unit cohesion.

- Providing leisure time and recreational activities, if possible.

- Training on how to conduct routine and special after action debriefings or rap sessions (and to use shift changes constructively for these purposes).

(3) Remember, it is not only direct patient care givers who undergo extreme stress. Do not forget food service, laboratory, maintenance, and administration personnel. Mortuary affairs personnel also require special support and consideration.

(4) The NP/CSC consultants work closely with MTFs’ and commands’ chaplains on these issues that create stress in health care providers and other medical personnel. The chaplains also deserve help in dealing with their own emotional responses. The CSC consultants themselves are not immune to stress and must rely on each other and the chaplains to share the strain. A plan for care of CSC personnel should be in place. The plan should provide for assessment of the emotional well-being of the CSC consultant. Use a rotating roster to assure that the mental health professionals are aware of the status of other team members.

(5) The consultant provides one-on-one or small group therapy when appropriate.

#### 4-7. Consultation During Demobilization and Homecoming

At the conclusion of the conflict, as military activities phase down or as units or individuals rotate home, CSC personnel advise command on stress issues.

a. *Scheduling Considerations.* The consultant strongly recommends that some free time be scheduled for all soldiers who are

deploying home. During this time, these soldiers are provided the opportunity to talk about their experiences with their comrades or with others who experienced similar stressors.

(1) These times when soldiers discuss experiences should be initiated days before departure by air. If sea transport is used, this could be accomplished during travel.

- Keep this time as free as possible from mission duties.
- Keep teams, squads, and platoons together.

(2) Keep unit personnel together for several days after reaching the home station.

- Do not immediately grant block leaves to the unit.
- Maintain a half-day, light-duty schedule.
- Grant soldiers liberal commander's time, as needed, to resolve personal problems.

(3) Appropriate memorial ceremonies and celebrations are recommended, both in the TO before departure and at the home station. These events recognize and provide comfort to those who have suffered. Such rituals give a sense of closure. These events should—

- Encourage grass roots participation rather than being dictated from above.
- Use or adapt traditional ceremonies.

b. *Postcombat Debriefing.* Combat stress control personnel will participate in formal

debriefings for leaders of small units, chaplains, and others, or for ad hoc collections of individuals with similar combat experiences. The CSC consultant may conduct or participate in such debriefings for units or individuals at special risk, such as former prisoners of war (POW) or victims of friendly fire. The debriefings for units or individuals begin while they are still in the TO, if feasible, and may continue soon after return to CONUS.

(1) The debriefings focus on the common experiences of war. These events may include—

- Traumatic experiences (death of buddies).
- Morally conflicting issues (death of noncombatants).
- Frustrations (rules of engagement, errors of leadership, and perceived failures of support).
- A feeling of loss at the breaking of the bonds formed with the combat unit.
- Delay in the rebonding with home and family.

(2) The soldiers are forewarned of the normal, common symptoms which combat veterans experience on return to a peacetime environment. Normal, common symptoms may include—

- Bad dreams.
- Alerting reactions to stimuli or situations similar to those of combat.
- A sense of being different and alienated from others who have not been through combat (including spouse and family).

This can lead to social withdrawal and perhaps a sense of letdown and boredom.

*c. Reunion Briefings.* Combat stress control personnel, chaplains, and others give group briefings to all soldiers and units. The briefers forewarn of the common strains that often develop in relationships between spouses and their families during long separations.

(1) Soldiers are prepared for the ways that their families, friends, and society may have changed since they were deployed. Special attention may be needed to explore popular feelings about the war and how veterans can expect to be treated by civilians. If this is likely to be negative, ways to cope are illustrated.

(2) While troops are being debriefed in the theater, similar debriefings should be conducted with families in CONUS to prepare them for the returning soldiers.

(3) When feasible, unit families are included in the later home station debriefings.

*d. Noncombat Debriefings.* Similar debriefing procedures are equally important following noncombat deployments such as 6-month peacekeeping rotations or prolonged training missions. Issues discussed are different.

*e. Continuing Debriefings.* A continuing debriefing process may extend over weeks or months in some special cases. Follow-up debriefings will be especially relevant when—

- Reserve Component units are demobilized after a prolonged period of active duty.
- Units are deactivated as a result of reduction in force.
- Large numbers of personnel are being considered for reduction in force. Such major changes are in themselves highly stressful and can lead to much inefficiency, distress, and long-term problems unless the personnel are supported and aided with coping skills and procedures.

## CHAPTER 5

## COMBAT STRESS CONTROL FOR RECONSTITUTION SUPPORT

## 5-1. Reconstitution Support

Reconstitution is extraordinary actions that commanders plan and implement to restore units to a desired level of combat effectiveness commensurate with mission requirements and available resources. Besides normal support actions, reconstitution may include—

- Removing the unit from combat.
- Assisting the unit with external assets.
- Reestablishing the chain of command.
- Training the unit for future operations.
- Reestablishing unit cohesion.

All CSC personnel should be thoroughly familiar with FM 100-9. The following summarizes the doctrine and elaborates on stress issues and mental health/CSC actions in support of unit reconstitution.

*a. Reconstitution Process.* Reconstitution of units transcends normal day-to-day force sustainment actions. It is defined as extraordinary actions that are planned and implemented by commanders to restore units to a desired level of combat effectiveness commensurate with mission requirements and availability of resources. Reconstitution is a total process. Its major elements are reorganization, assessment, and regeneration, in that order.

(1) Reorganization primarily involves a shifting of internal resources and is accomplished as either immediate or deliberate reorganization.

(a) Immediate reorganization is the quick and usually temporary restoring of degraded units to minimum levels of effectiveness. Normally, the commander implements it in the combat position or as close to that site as possible to meet near term needs.

(b) Deliberate reorganization is done to restore a unit to the specified degree of combat effectiveness. Usually, more time and resources are available further to the rear. Procedures are similar to immediate reorganization except that some personnel and weapons system replacement resources may be available, equipment repair is more intensive, and more extensive cross-leveling is possible.

## NOTE

When used in reorganization, cross-leveling involves the movement of personnel and/or equipment between units to achieve equalization. The process is accomplished while maintaining or restoring the combat effectiveness of the units involved.

(2) Assessment measures a unit's capability to perform its mission. It occurs in two phases. The unit commander conducts the first phase. He continually assesses his unit before, during, and after operations. If he determines it is no longer mission capable even after reorganization, he notifies his commander. Higher headquarters either changes the mission of the unit to match its degraded capability or removes it from combat. External elements may also have to assess the unit after it disengages. This is the second phase. These elements do a more thorough evaluation to determine regeneration needs. They also consider the resources available.

(3) Regeneration is required when heavy losses of personnel and equipment leave a unit combat ineffective and unable to continue its mission. Regeneration has two variations: incremental regeneration or whole-unit regeneration (*a* and *b*, below, explain each). Regeneration involves rebuilding a unit through large-scale replacement of personnel, equipment, supplies, and if required, internal reorganization; reestablishing or replacing essential C2; and conducting mission essential training for the reconstituted unit.

(a) Incremental regeneration is the massive infusion of individual personnel replacements and single items of equipment into the surviving unit elements.

(b) Whole-unit regeneration is the replacement of whole units, or definable Subelements such as squads, crews, and teams.

*b. Authority for Reconstitution.* Reconstitution decisions belong to the commander. The commander controlling assets to conduct a regeneration decides whether to use resources for this purpose. The commander of the attrited unit decides to reorganize when required. The unit commander begins the reconstitution process.

*c. Characteristic of Regeneration.* The defining characteristic of regeneration, as distinct from simple internal reorganization or consolidation, is the massive infusion of personnel, equipment, and assistance at the direction of higher headquarters. The process begins with an initial survey by a team sent by the higher headquarters. This team determines the status and needs of the attrited and exhausted unit as it moves to the regeneration site.

(1) Combat stress assessment of unit personnel should be included in the initial evaluation. The supporting medical element should include CSC personnel (teams) as part of their initial regeneration support efforts to the

unit. Some of the key issues in estimating the CSC needs of the unit include—

- Determining the percentage and nature of casualties.
- Looking at the duration of operations and environmental exposure.
- Estimating the loss and current effectiveness of leaders.
- Evaluating attitudes, perceptions and level of confidence of unit survivors.
- Evaluating the status of nutrition and hydration.

(2) The scale of CSC involvement depends on the size of the unit, the nature and extent of the attrition it has suffered, the location of the reconstitution site, and the time and resources available.

(3) The S1/G1, S4/G4, and medical staffs also coordinate the dispatch of the regeneration task force teams. These teams occupy the reconstitution site before arrival of the exhausted unit. The reconstitution task force guides each element of the arriving units into its designated areas. The regeneration task force provides for the immediate needs of the survivors. This should include personal gear, sleeping bags, and tentage to replace lost or damaged items. Assistance teams may include cooks, medical teams, repair and maintenance teams for vehicles, and ordnance and special equipment personnel. Medical teams provide sick call services while organic medical personnel rest. As required, CHS and other teams may include—

- Combat stress control personnel/team.
- Preventive medicine team.



- Dental team.
- Nuclear, biological, and chemical decontamination teams.
- Personnel service team.
- Combat service support contact teams.

Replacement personnel are sent to the reconstitution site, and when present, CSC personnel will assist with their assimilation into the regenerated unit.

*d. Scope of Combat Stress Control Involvement in Reconstitution Support.* The CSC reconstitution support mission ranges from providing assistance to small units close to the battle that are undergoing reorganization to providing assistance to large units involved in regeneration conducted far to the rear.

(1) Combat stress control reconstitution support may not be available for small unit-level elements such as a platoon undergoing immediate reorganization. If CSC personnel are deployed this far forward, the CSC reconstitution support mission will merge into the consultation mission to units held in reserve. Ideally, a two or four-person CSC team might deploy to a company-sized unit with the other maintenance and medical teams. The CSC team assists the command with the deliberate reorganization of small unit-level elements and facilitates after-action debriefings by and for all leaders in the company. The CSC team may conduct critical event debriefings if the unit has experienced an especially traumatic (tragic, horrible) event. The CSC team could also conduct critical event debriefing if the after-action debriefing shows other issues need to be resolved. The availability of the CSC team and the time to provide such support will depend on mission priorities and current work load.

(2) Combat stress control reconstitution support requirements for larger units that are undergoing regeneration in the division rear, corps, or COMMZ will vary. Factors which influence the requirements include—

- The size of the unit.
- Number of subunits which have suffered heavy casualties.
- The extent of emotional trauma.
- Time available.

Combat stress control personnel required to support regeneration is dependent on the above factors. A guideline is provided in Table 5-1.

*Table 5-1. Guideline for Combat Stress Control Personnel Required to Support Reconstitution*

SIZE OF UNIT	CSC PERSONNEL REQUIRED
COMPANY	2-4
BATTALION	6-12
BRIGADE	12-30
DIVISION	30-60

*e. Phases of Combat Stress Control Reconstitution Support.* Reconstitution support is divided into phases, based on the changing of the unit. The pattern is similar to that of restoration of an individual BF casualty. The relative time and effort required for each phase varies, depending on the recent experience of the unit. For example, physical/physiologic replenishment may be extremely important in some situations and completely unnecessary in others.

**NOTE**

The following paragraphs pertain to the phases of CSC support provided to combat arms units which have been engaged in heavy, continuous fighting.

**5-2. Phase I: Preparation and Deployment**

*a. Coordination.* Coordination for deploying a CSC reconstitution support mission is accomplished through the supporting medical unit.

(1) The headquarters which orders the reconstitution effort must be aware of the importance of CSC involvement in the task and of the availability of resources. The command surgeon is responsible for recommending what CHS assets are committed for reconstitution support. It is the responsibility of the CSC commander or the psychiatrist to provide consultation training to all command surgeons so they are aware of the importance of including CSC personnel in all reconstitution operations.

(2) The initial evaluation team should include a CSC member. Depending on the size and location of the unit, this could be—

- A brigade CSC team member.
- The division psychiatrist or a mental health officer from the division mental health section or attached CSC elements.
- A psychiatrist or a mental health officer from the medical company, CSC or the medical detachment, CSC.
- An ASMB psychiatrist, social work officer, or NCO in the corps.

- The medical group social work officer or psychologist,

- The medical brigade or MEDCOM psychiatrist or social work officer.

(3) Movement orders for the evaluation team and for the subsequent assistance team are generated and coordinated by the higher headquarters (for example, the FSB, DISCOM [DMOC], or medical group headquarters). The CSC elements move as part of a convoy with the other contact teams and CSS elements.

*b. Familiarity with the Unit.* Reconstitution support works best when the attrited unit already has familiarity, trust, and confidence with the CSC personnel (teams). Those CSC personnel need to be familiar with the unit, its history including recent experiences, equipment, mission, and key people. Ideally this includes at least a few known, face-to-face POCs. If that is not available, a positive reputation with strong endorsements from respected second parties helps. The endorsement of the higher headquarters is essential.

*c. Unfamiliarity with the Unit.* A CSC team which deploys to a completely unfamiliar unit under these extreme stress conditions will be at a disadvantage but can overcome it by—

- Getting all the information it can on the unit prior to arrival.
- Coordinating with and using the chain of command, chain of support, organic mental health, and medical personnel and chaplains to obtain information.
- Demonstrating competence (quickly), self-sufficiency, and helpfulness without appearing as if trying to step in and take over.

### 5-3. **Phase II: Reduction of Human Physical/Physiologic and Cognitive Stressors**

a. *Monitoring.* The CSC team monitors the unit to assure that the following steps are taken by unit leaders and the reconstitution support elements. The CSC personnel ensure, as needed, that the following aspects of reconstitution treatment are being accomplished. They report any short-falls to the reconstitution control element.

#### NOTE

The SI/GI and S4/G4 staff of supply and services or quartermaster units is responsible for providing the means for warming or cooling, rehydrating, feeding, and sheltering. They are also responsible for latrine and shower facilities. These are not the responsibilities of CSC personnel or units.

(1) Treat environmental exposure immediately by providing shelter, cooling, warming, and/or drying, as necessary.

(2) Push oral, palatable fluids immediately (cool or warm, depending on the temperature) to correct probable dehydration.

(3) Provide plenty of good palatable food, mostly carbohydrate but with some protein, and as much as they want to eat. The food may be soups which simplify preparation and combine feeding and fluid replacement. A-rations are best. Tray-packs are acceptable but require special effort. Heating tray-packs will improve texture; providing optional condiments and spices will be a plus. Meals, ready-to eat (MREs) also can be used if efforts are made to heat them and additional condiments are provided.

(4) Ensure leaders and troops are given a brief orientation on what they will be doing and when it will happen.

(5) Provide hot showers right away, if feasible. If not feasible, the unit should be provided time for sleep as soon as possible.

(6) Allow for sleep under the best conditions possible for 8, 12, or 16 hours (depending on the degree of sleep debt and the amount of time available).

(a) It is best to sleep through the night and awaken in the morning to continue the program, but in forward locations this may be reversed (sleep in the day, awaken at night) to maintain reverse cycle requirements.

(b) If possible, have other units provide perimeter security so that all members of the exhausted unit can sleep at the same time.

(c) Unit leaders need this sleep most! The reconstitution support elements provide security and all necessary support actions, while unit leaders are ordered to sleep so they will not feel that they have to stay awake.

(d) If necessary, the CSC team psychiatrist prescribes fast-acting medications that are rapidly eliminated from the body. For example, diphenhydramine (Benadryl), or ternazepam (Restoril) are given to those key personnel who do not relax and respond positively to strong suggestion or approval. Low dose diazepam (Valium) is permissible under some circumstances but not preferred. Chlorpromazine (Thorazine) should not be used for this purpose. Before administering minor tranquilizers, the prescriber must ascertain if the soldier has a history of alcohol or drug abuse and specifically if the soldier is in recovery.

*b. Involvement of Combat Stress Control Personnel During Physical/Physiologic Replenishment.* The importance of physical/physiologic measures should not be underestimated in the haste of the reconstitution efforts. Combat stress control elements through their actions should encourage and facilitate their speedy delivery.

(1) Delay, loss, or nonavailability of equipment and materials when and where needed may hamper the speedy delivery of physical/physiologic measures. If this happens, the CSC teams along with other medical support and CSS teams must be prepared to step in and assist the attrited unit to improvise self-help.

(2) Combat stress control teams facilitate the means to boil water to heat tray-packs or MREs, to prepare hot soups, and to provide hot water for shaving, sponge baths, or bucket showers. Personnel from the reconstituted unit will provide most of the labor.

(3) Facilitating restorative sleep under adverse conditions is more difficult because CSC units do not carry large volumes of sleeping bags, ground pads, cots, or tents. They can provide disposable ear plugs (an effective way to dampen distracting background noise) and cravats (to cover eyes against bright daylight). Disposable foil "space blankets" should be available for use in cold or wet weather when better shelter and bedding are not available.

(4) During the intensive physical replenishment phase, the CSC personnel will learn as much as they can about the recent experiences of the involved unit and coordinate a plan of action to meet the specific needs of the unit and its situation.

*c. Continuing Physiologic Replenishment.* After sleep, physiologic replenishment continues.

(1) Unit personnel are awakened for a good, hot, high-protein breakfast (A-ration if possible; tray-pack is acceptable if well-heated when served).

(2) Unit personnel work to restore hygiene (shower, shave, good latrine facilities, and clothing exchange) and take care of personal gear.

(3) Some CSC personnel assist by organizing self-help activities involving the troops as the unit's leaders concentrate on the debriefing process. These CSC personnel continue to gather data by—

- Observation.
- Structured interviews with individuals or small groups.
- Short, easily scored questionnaires.

#### 5-4. Phase III: After-Action Debriefing

*a. Small Team and Subunit After-Action Debriefing.* Surviving unit leaders begin the after-action debriefing process during lulls in the battle or as soon as the mission or time permits. In some instances, the after-action debriefings may not be accomplished until the unit reaches a reconstitution site. Standard after-action debriefings as described in FM 22-51 will be conducted by all unit elements to obtain a clear and accurate assessment of what really happened. After-action debriefing will be conducted by the leaders of teams, crews, squads, sections, and platoons within the company. If the original leader was replaced, the new leader will conduct the after-action debriefing. Attached personnel, such as medics, forward observers, engineers, or artillery fire support team, are included in the unit after-action debriefings.

*b. Ascending Levels of Leader After-Action Debriefing.* Once the subunit debriefings are completed, the company commander conducts his after-action debriefing for the subordinate leaders. Subsequent debriefings are held at battalion, brigade, and even division levels in large scale reconstitution efforts. The unit's TSOPs will identify who attends the after-action debriefing at a particular level. For example, at the company level, all the leaders in the company will attend the company commander's after-action debriefing. The battalion commander's after-action debriefing will involve all company commanders, first sergeants, key battalion staff, sergeants major and may be key NCOs within the battalion. Regardless of what level the leader attends, he brings his unit's/subunit's consensus (reconstruction) of what really happened. Also, he is prepared to brief about the emotional reactions of his personnel to the events that occurred. The participating leaders share their information along the succeeding time-line of the larger operation. The senior commander, NCO, and key staff personnel contribute their input to the reconstruction of the event. As in the AAR, the after-action debriefing identifies operational lessons learned. In addition, the after-action debriefing shares, acknowledges, and normalizes the feeling raised by the event. It also enhances vertical and horizontal bonding of personnel which is the essential framework of unit cohesion. The senior leaders then take the group's consensus (reconstruction) on to the next higher level of leader debriefing. The process of after-action debriefings from the bottom up has the following advantages:

- Each level can reconstruct the most accurate picture possible of what actually happened. They build upon the already clarified memories and observations of each subunit.
- Misconceptions, misunderstandings, and unrealistic expectations are likely to be

clarified. The right lessons are more likely to be learned.

- The junior leaders can communicate their clearer understanding of the larger picture back down to their subordinates.
- It provides transition workshops for new leaders if the unit has suffered a loss of key leaders and staff. If a new commander is required, this type of workshop facilitates his assumption of command.

*c. Large Group Debriefings.* At each level, it may be possible for soldiers and junior leaders to listen to the next higher level of leader debriefing(s). This, in effect, constitutes a large group briefing. Large group debriefings involve lower echelon personnel. However, large group debriefings can only be conducted at a relatively safe site. There must be adequate time to conduct the debriefing. The large group debriefings are not conducted if personnel are involved with equipment repair, reissue, and other recuperative activities. The large group debriefing maximizes the sharing of common experiences and the extension of unit cohesion.

*d. Attached Support Personnel (Specialty Branch) Debriefings.* Attached personnel will participate in the after-action debriefing process with the unit to whom they are attached. They contribute their own perspectives on the event in concert with other attached support personnel. Later, if METT-T at the reconstitution site allows, these support personnel should be drawn together by their parent units to debrief. The objectives of this specialty debriefings is to derive lessons learned and to express and normalize the intense emotions involved. Unlike the small unit or leader after-action debriefings, the specialty debriefings will usually not be reconstructing the overall event on a common time line. Rather, they share their different

experiences of practicing their common specialty in different situations.

e. *Facilitators in After-Action Debriefings.* When a unit has suffered especially distressing or traumatic events, the commander should request trained facilitators to assist with the debriefing process. These facilitators should be present with the unit through all levels of the after-action debriefing process. The higher headquarters of the unit that has experienced a traumatic event should request debriefing facilitators and assure that they are available at the scheduled time and place. Certain situations are best handled by trained facilitators. These situations may include—

- Teams or units whose key leaders were casualties or were replaced and now new leaders are conducting the debriefing.
- Serious friendly fire incidents or other disastrous mistakes.

(1) It is essential that the facilitators be perceived as impartial, friends of the units, trustworthy, and privileged to maintain confidentiality about what is shared in the debriefing. They must not be perceived as investigators or “spies” from the higher headquarters, inspector generals, or criminal investigators.

(2) The facilitators should have received formal instruction in critical event debriefings. Ideally, they will have participated in or led prior critical event debriefings.

(3) The trained facilitator can be from the CSC or mental health team. He may be an officer or NCO of any professional or para-professional discipline. Line unit officer or NCOs (peer debriefers) who have had critical event debriefing training can also be effective facilitators.

(4) The trained facilitator assists the after-action debriefing process by—

- Helping the debriefing leaders assure the ground rules are clearly stated and understood by all personnel.
- Asking questions to get a clear picture of what actually happened—when, where, how, and to whom.
- Assuring that the complete time line is filled in, extending from before the critical incidents all the way through to the aftermath.
- Assuring the process stays constructive and does not turn destructive.
- Ensuring the ground rules are followed, military bearing and respect maintained, and verbal attacks or scapegoating not permitted.
- Assisting with the validation and normalization of feelings, such as fear, guilt, and grief, as they come out by providing the broader or expert perspective.
- Monitoring the participants for signs of serious distress and/or detachment or psychological withdrawal from the group.
- Encouraging those soldiers with signs of serious distress to work through the distress or withdrawal during the debriefing.
- Checking with those individuals one-on-one after the debriefing.
- Providing group with information about what assistance is available to help them with working out their distress.

- Advising the unit and leadership about whether a follow-up formal critical event debriefing would be worthwhile.

#### NOTE

Often, a well-facilitated, after-action debriefing will make a formal critical event debriefing unnecessary.

*b. Conducting Critical Event Debriefings.* Information obtained by after-action debriefings or from the higher headquarters pertaining to the traumatic event is provided to CSC personnel. This information is used to determine which subunits need more direct involvement. Critical event debriefings are then scheduled (with the approval of the leaders that were involved) with those units/subunits where a highly disruptive or traumatic event occurred. Combat stress control personnel will conduct the critical event debriefing or will advise (previously trained) unit chaplains and medical participants on how to conduct the critical event debriefings.

(1) The need for critical event debriefings is indicated by—

- Evident distress of many participants.
- A consensus of the participants at the after-action debriefing that they want to talk more about the event.
- Evident reluctance of unit members to talk through the event in the after-action debriefing under their own leadership.
- The expressed wish for a consolidated or combined debriefing, bringing the unit together with representatives of other involved units, such as the survivors of a friendly fire incident with the perpetrators.

#### NOTE

At least one trained and experienced critical event debriefing facilitator should be included in critical event debriefings.

(2) The techniques of a critical event debriefing are similar to those of after-action debriefings but are more dependent on the skills and experience of the facilitator. The facilitator must be able to recognize and intervene to help those in serious distress.

#### 5-5. Phase IV. Rebuilding Unit Cohesion

*a. Assisting Units to Rebuild Cohesion.* Combat stress control personnel advise the commanders and staff on planning the reassignment of surviving unit members and the assignments of replacements. This advice is based on the results of the leader-level debriefings, AG information, and any other pertinent observation/data collected by the CSC team. The objectives of this process are to maximize remaining unit cohesion and promote new bonding. Some of the techniques and principles that may be employed to maintain enhance unit cohesion during the redistribution and replacement process include—

- Keeping a new/replacement buddy pair, crew, or small team together and assigning all members to the same platoon or section of the attrited unit. Depending on the specific circumstances, new/replacement personnel may not be kept together. They may be dispersed among small closely-knitted groups of veterans.
- Assigning veteran soldiers from other attrited units or sections so that level of expertise is not lost. These personnel should also

be transferred as crews or teams, or at least as buddy pairs.

*b. Small Unit Leaders and Veterans Integrate New Replacements.* Small unit leaders actively integrate all new soldiers while CSC personnel, unit ministry teams, or medical platoon members monitor and provide feedback. New replacements are introduced throughout the unit. Group discussions are conducted for—

- Combinations of older veterans reassigned from other parts of the unit.
- Newer veterans returning to duty from medical channels.
- Replacements from rear area jobs in corps and COMMZ.
- Replacements fresh from CONUS.

In these group sessions, the story of the recent action, as clarified in the after-action debriefing, are discussed. Feedback to the small unit leaders from, CSC personnel pertaining to the process should include—

- Identifying potential problems and recommending solutions.
- Recommending additional meetings with CSC personnel for further ventilation, discussion, or work group sessions.
- Recommending individual or group training on combat stress, stress management, relaxation techniques, and BF.
- Recommending unit leaders, assisted by chaplains, conduct memorial services for the unit's dead.

*c. Assisting Individual Soldiers with Battle Fatigue.* Small unit leaders may identify

BF soldiers as a result of unit after-action debriefings. When soldiers are provided the opportunity to talk about what has really happened to them, they may exhibit true signs of BF. This may be apparent as one observes their reactions, interactions, and behaviors during the debriefing process. Battle fatigue cases may be identified by their leaders or buddies, by self-referral, or by the CSC staff observations. When these soldiers are identified as having BF, begin treatment without flagging them as patients.

(1) Since the unit is in a stand-down position. CSC personnel can initiate treatment quickly. They will determine the severity of the BF and initiate rest, light duty, or other appropriate activities.

(2) Those BF cases that temporarily require continuous medical observation may be rested and watched by the treatment team (part of the reconstitution support package) or at the BAS after its personnel have the opportunity to rest.

(3) A few of these BF cases may require evacuation, but only to the next rearward echelon.

## 5-6. Phase V: Performing Final Combat Stress Control Requirements for Reconstitution Support

*a. Phase V.* Phase V begins after the newly reconstituted unit has had additional sleep, food, and opportunities for hygiene. Unit personnel, during this phase, are working actively with each other and with the reconstitution support teams to prepare the unit for return to combat.

*b. Unit Cohesion.* Combat stress control personnel monitor the ongoing work activities to ensure that unit cohesion is being built and



that veterans are accepting and teaching the new replacements. Questionnaire-type surveys may be administered to collect comprehensive data. Combat stress control personnel continue to advise unit leaders and facilitate further group work sessions and transition workshops. Note that the word is facilitate, not lead or direct.

*c. Building Unit Confidence.* The successful completion of military training, such as crew drills, squad and platoon tactics, and field training exercises (FTXs), will assist in building unit cohesion and confidence. Depending on the location and time available, CSC personnel may help commanders organize recreational activities and/or sports competitions. Sporting activities

can provide confidence-building and stress-reducing physical exercise. They are scheduled in ways which maximize the development of familiarity and cohesive bonds within and between the recently reassembled unit.

*d. Closing Out Reconstitution Support.* It is essential that the reconstitution support team close out (officially end) its role with each unit in the formal reconstitution process. The reconstituted units are left with positive expectations that the unit and its individual soldiers will be able to perform their mission and do well on their own. Ideally, the same CSC personnel (team) will continue to provide CSC support when the unit returns to combat.

## CHAPTER 6

## COMBAT NEUROPSYCHIATRIC TRIAGE

## 6-1. Triage

*a. Definition and Comparison.* Combat NP triage is the sorting of BF, NP and substance abuse cases (including those with physical injury) based on how far forward they can be managed and treated to maximize rapid RTD. Combat NP triage derives from the proven combat psychiatry principles of PIES (Proximity to the unit; Immediacy in initiating treatment for all cases; expressed Expectancy of providing rapid and full recovery; and Simplicity by using simple and short treatment methods. )

(1) Combat NP triage is fundamentally different from surgical triage. Surgical triage divides cases into the categories of Immediate, Minimal, Delayed, or Expectant based on how soon, if at all, they will go to surgery. The Immediate cases go to surgery immediately because any delay is likely to result in death or permanent disability, such as loss of a limb. Minimal cases do not require surgery and can RTD with a minimal investment of time and effort. In surgical triage, stress and psychiatric casualties would all be categorized as Minimal because they never go to surgery. Delayed cases can wait for surgery without suffering increased risk of permanent harm. Expectant cases are not expected to survive, given the amount or type of treatment that is available to give them, so they do not go to surgery at all.

(2) With BF, however, there is a significant increased risk of lifelong psychiatric disability from prolonged delay of treatment, just as there is a risk of physical disability from delay of medical-surgical treatment. Most cases are expected to recover and RTD with prompt and correct treatment, no matter how disabling their symptoms appear. For these reasons, triage officers need to be taught that stress and psychiatric casualties need to be referred for treatment as soon as possible. It should always be remembered

that a small number of NP cases may have weapons and be so potentially dangerous that they deserve the highest priority for management regardless of the type of triage being conducted.

(3) In combat NP triage, diagnostic knowledge, experience, and sound judgment are important at the front end of the process and at the most forward feasible echelon. Interviewing skills are essential if potentially critical mental symptoms, such as paranoid or suicidal ideation and thought disorders, are to be identified. Those symptoms bear directly on safe management. In such cases, diagnosis itself is deliberately deferred. The decision on where to send the case is determined on whether the case can be managed safely for hours to days with simple treatment at the forward echelon. If manageable, they remain with the forward echelon. If they are unmanageable, they are sent rearward only one echelon where the decision process is repeated.

*b. Combat Neuropsychiatric Triage Categories.* Combat NP triage involves the sorting of cases into categories based on where they can be treated. There are four combat NP triage categories. The four categories are—

- DUTY cases.
- REST cases.
- HOLD cases.
- REFER cases.

(1) DUTY cases return to their original small unit, either for full duty or for light duty with extra rest and replenishment. This option depends on the small unit's mission, resources, and the soldier's symptoms. The triager must, therefore, be familiar with the unit's situation and take that into account.

## NOTE

Maneuver units positioned in forward areas must have only personnel who are fit for full duty. Limited or light duty is nonexistent in these units. If BF cases are sent forward to these units, they must be able to perform full duties for their own safety and the safety of the unit.

(2) REST cases are not return immediately to the small unit because the unit cannot provide an adequate environment for rest. REST cases need brief respite, physical replenishment, and less demanding duties for hours to days at a less dangerous or better-resourced setting. These cases do not require close medical or mental health observation or full-time treatment. The respite and replenishment can be provided in a nonmedical CSS element which supports their original unit. This option, too, depends on the resources and mission of the available CSS units as well as on the soldier's symptoms. Someone in the receiving unit must take responsibility for ensuring the soldier is fed, rested, performing some useful work, and kept accounted for. There must be a reliable transportation link to return the soldier to his original unit after a day or two of rest.

(3) HOLD cases are those who do require close medical observation and evaluation because either—

- Their symptoms are potentially too disruptive or burdensome for any available CSS unit or element.

- Their symptoms could be caused by a medical, surgical, or NP condition which could suddenly turn worse and require emergency treatment.

In addition, the resources to provide the necessary medical observation and adequate stabilization or

emergency treatment of the potential emergency must be available at this medical echelon.

(4) REFER cases present problems similar to the HOLD cases, but—

- REFER cases are too disruptive and burdensome for this medical echelon, given its mission and resources.

- This echelon cannot provide the acceptable level of diagnostic and treatment capability if an emergency occurs.

c. *Distinguishing Categories by Signs and Symptoms.* It should be obvious that the four combat NP triage categories are not sharply distinguishable based on the signs and symptoms of the case.

(1) The boundaries of each category are influenced as much or more by the changing tactical situation and the resources available as by the symptoms. The category may change automatically with time or as the case moves through the system. For example, REFER automatically becomes HOLD when the cases reach the echelon which can manage and treat them.

(2) This flexibility is entirely in keeping with the intent of the labeling system for BF soldiers. The intent is to avoid giving BF soldiers a psychiatric label that sticks with them for life. It is also in keeping with the highly changeable nature of BF symptoms. Battle fatigue symptoms tend to become fixed when inappropriately labeled and mistreated.

(3) Like the triage categories in surgical triage, the categories in combat NP triage are brevity codes. Each brevity codes (labels) summarizes in one word where the case should be managed and what treatment should be received in the immediate short term given the current situation. It has no other meaning and only transitory relevance. Figure 6-1 provides a decision tree or flow diagram for sorting in combat NP triage.

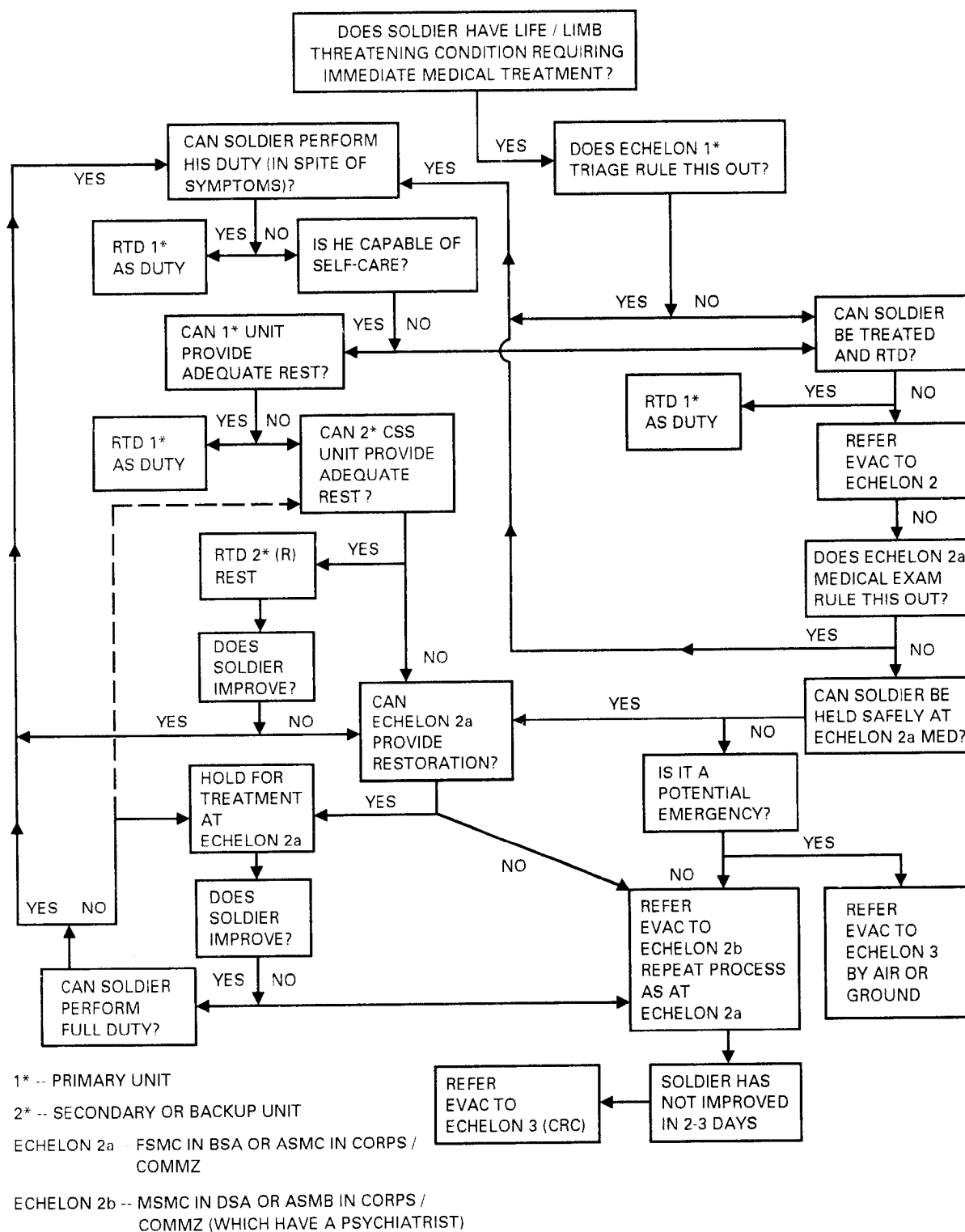

Figure 6-1. Combat neuropsychiatric triage flow diagram.

**6-2. Considerations**

a. *Importance of Expertise of Medical and Mental Health Personnel.* As noted above, making the diagnosis of specific psychiatric disorders is officially deferred when managing BF. However, the medical and mental health personnel must be alert to the fact that many physical or psychiatric illnesses may resemble BF, yet require specific and even emergency treatment. It may be a matter of life or death to correctly make those diagnoses early. In more severe cases of BF, there is increased difficulty in recognizing such illnesses, and the expertise of medical personnel is particularly important. Either the psychiatrist or the clinical psychologist should make diagnostic evaluations if the present of an NP disorder is suspected or must be differentially diagnosed.

(1) *Physical screening.* All REFER and HOLD cases deserve an adequate review of body systems and a quick physical examination. The examination includes vital signs, head/eyes/ears/nose/throat, chest, abdomen, and extremities with simple testing of reflexes and muscle strength. Negative or normal findings need to be documented on the FMC or according to AR 40-66. Any positive findings from the physical examination should, of course, be evaluated further. If the examiner has not checked various body systems, it is not reassuring to tell a soldier that his physical or mental complaints are "only BF." DUTY and REST cases should also get this brief examination when time and setting allow.

**NOTE**

Previous observations in FTXs suggest that the physical examination is often neglected for cases who have been labeled stress, BF, or psychiatric. *This undermines the credibility of the BF diagnosis and must not be allowed.*

(2) *Neuropsychiatric screening.* Problem cases will require examination by a physician with NP training. This expertise must be available no further to the rear than the DSA (AR 40-216), and whenever feasible, should be available at the BSA.

(a) All physicians and physician assistants must be able to perform and document neurological screening and mental status examinations in order to identify problem cases.

(b) The other mental health disciplines must also be trained to perform a basic physical screening examination. These personnel include clinical psychologists, social work officers, occupational therapists, and appropriate enlisted personnel.

(3) *Considerations during physical screening.* While a brief physical examination is essential, the clinician must resist the temptation to order tests or procedures that do not directly influence case management. Do not, for example, draw lines on the soldier's skin to document where the changes in sensation occur. Such lines, and medical tests in general, tend to validate and fix the symptoms in the mind of the patient. Needless tests may delay RTD and provide a distinct incentive to remain incapacitated because of secondary gains, especially if there is a chance of evacuation to a safer, more comfortable area.

(4) *Treatment considerations (overtly and covertly).* The work-up therefore should be limited to those essential steps which ensure the medical safety of the soldier and determine whether he can—

- Return to his unit.
- Return to another unit for

rest.

- Receive treatment at this medical facility.
- Be evacuated to the next rearward echelon.

If no threat to life or permanent function is involved, it is often best to treat overtly for BF while monitoring covertly and providing general treatment for the other possibilities.

(5) *Restoring confidence after temporary disability.* As BF is often caused by a combination of mental, physical, and physiologic stressors, there is no need to try to force the soldier to accept emotional rather than physical explanations for his inability to function well. Many soldiers find it easier to recover confidence if they can believe that most of their problems resulted from physical overload. The term BF deliberately covers both sets of causes.

(6) *Ruling out serious medical/surgical causes.* If soldiers who are believed only to have BF must be evacuated to a hospital for diagnostic tests to rule out worse possibilities, they should be told specifically that this is just a precaution. They should be seen immediately on arrival by the hospital psychiatrist and scheduled for the tests as soon as possible. The Principle of Immediacy requires that expedient treatment be provided. Such BF cases are not routine cases and should have priority just below that of soldiers with life- and limb-threatening physical diagnoses. Remember, BF soldiers can suffer lifelong psychological disability as a consequence of delay.

b. *Importance of Recognizing Physical Conditions.* Paragraph 6-3 lists some of the physical conditions which should be kept in mind in the differential diagnoses of BF. Some of these conditions may exist concurrently and be a contributing cause to the BF, but require specific additional treatment.

### 6-3. Differential Diagnostic Problems

a. *Low-Grade Environmental or Stress-Related Illnesses.* Low-grade environmental or stress-related illnesses drain the soldiers' strength and confidence. Chronic diarrhea and slight fever from subclinical malaria or a virus may exhaust, demoralize, and contribute to BF among soldiers. These conditions should be treated medically, concurrently with the physical replenishment, rest, reassurance and organized activities which restore the soldier's confidence. If they persist in spite of rest and symptomatic treatment, a more aggressive workup and treatment is indicated.

b. *Dehydration.* Dehydration deserves special mention because it can be very subtle. Soldiers under battlefield or heavy work conditions become extremely dehydrated without feeling thirsty. This is especially likely in mission-oriented protective posture (MOPP) and/or arctic gear. In both conditions, it is mechanically difficult to drink. An insufficient circulation of thick, dehydrated blood is less able to carry oxygen to the brain and muscles. This can result in instant BF.

c. *Hyperthermia.* Hyperthermia (overheating) in an otherwise healthy individual often first causes mild elation and excessive energy. This may be followed by irritability, disorientation, and confusion. When core body temperature reaches 105° to 106°F, the soldier may become belligerent, combative, and have visual hallucinations. If brain temperature rises further, the soldier collapses and convulses in heatstroke. These soldiers may require restraints and must be cooled as rapidly as possible. In hot climates, hyperthermia is expected, but it can occur in chemical protective gear (MOPP), cold weather clothing, or during heavy physical work even in temperate and cold climates. As these examples illustrate, hyperthermia is caused by a mismatch between environment, activity, clothing, and shelter.

*d. Hypothermia.* Hypothermia may cause an individual to become disoriented when core body temperature falls below 94°F. The person may move and speak slowly. His skin looks and feels warm, leading him to take off clothing. He may even resemble a zombie. Hypothermia is as likely in cool, or even warm (night-time), wet climates as it is in extremely cold ones. It is also caused by a mismatch between environment, activity, and clothing or shelter. Heat must be provided to the hypothermic soldier to prevent death. If the soldier is extremely hypothermic, care must be taken to avoid cardiac arrhythmia during rewarming.

#### NOTE

A simple rule of thumb is: If the soldier is overheated, help him cool off. If there is any possibility he is cold or hypothermic, warm him up. Have him drink cool or warm liquids suitable for the condition since he is probably dehydrated.

*e. Overuse Syndromes.* Overuse of muscles, joints, and bones that have not been prepared for the strain of field duties can lead to persisting stiffness, pain, swelling, and orthopedic injuries. If severe, these injuries may require evacuation to a hospital for evaluation by an orthopedic surgeon, an occupational therapist, or a physical therapist. Even if these injuries are avoided, the unfit person who overexerts have days of stiffness, aching, and weakness. During this time, such cases are likely to have BF if further demands are made on them. Physical fitness exercises are a regular part of the treatment of BF. For these cases, the exercises should first be limited to warm-up and stretching-type calisthenics.

*f. Rhabdomyolysis.* Rhabdomyolysis is one potentially dangerous complication of severe

muscle overuse (and of heatstroke or crush injuries) in which myoglobin from damaged muscle cells injures the kidneys. This can cause acute renal failure and death, or chronic renal insufficiency. A warning sign is dark (tea-colored) urine, but without laboratory testing, this is not easily distinguished from the concentrated urine of dehydration. Cases with significant rhabdomyolysis should be evacuated immediately to a hospital. If kidney failure develops, they should be evacuated to CONUS.

*g. Head Trauma.* Concussion may stun the individual and cause amnesia, residual confusion, and perhaps impulsive behavior. For any case of suspected head trauma and for any case of significant memory loss (especially for a discrete period of time), check scalp, eyes, ears, nose, cranial nerve signs, and vital signs for evidence of head injury. Negative as well as any positive signs are recorded. The main concerns are—

(1) Epidural hematoma (a blood clot forming between the skull and the tough membrane that covers the brain). This is usually due to arterial bleeding, with onset of symptoms of increased intracranial pressure within minutes to a few hours. It can progress rapidly to coma and respiratory arrest.

(2) Subdural hematoma (a blood clot forming between that tough membrane and the brain itself). This is usually venous bleeding with slower onset and progression but can lead to coma and death.

(3) Intracranial pressure with either epidural or subdural hematomas which may become life threatening. If one pupil becomes larger than the other, there is little time left to evacuate the soldier to a hospital. Hyperventilating the soldier can buy time by decreasing blood flood to the brain and temporarily reducing intracranial pressure. An organic or attached

surgical squad may drill burr holes to relieve intracranial pressure. When a surgical squad is not present, these patients are evacuated to the supporting hospital by the most expedient means available.

(4) If a head injury is suspected, continue to monitor mental status and vital signs periodically, especially respiration even though physical findings are negative. Continuous

monitoring would be appropriate if there are serious concerns about the risk. In addition, the soldier is awakened every hour to check and record state of consciousness according to the Glasgow Scale (Table 6-1). Allow sufficient time after awakening for the soldier to recover from the normal sleep inertia (grogginess on awakening). This precaution will only slightly decrease the restorative quality of the sleep which can be made up by letting the soldier sleep longer.

*Table 6-1. The Glasgow Coma Scale*

---

<b>EYE OPENING (E)</b>		
SPONTANEOUS OPENING	=	4
OPENS IN RESPONSE TO SPEECH COMMAND	=	3
OPENS IN RESPONSE TO PAIN	=	2
NIL (NO RESPONSE)	=	1
<b>MOTOR RESPONSE (M)</b>		
OBEYS REQUEST TO MOVE SOME PART	=	6
LOCALIZES (MOVES HAND TO TOUCHED PLACE)	=	5
WITHDRAWS PART FROM PAINFUL TOUCH	=	4
ABNORMAL FLEXION (ELBOWS, WRISTS BENT)	=	3
EXTENSOR RESPONSE (ARMS, LEGS STRAIGHT)	=	2
NIL (NO RESPONSE)	=	1
<b>VERBAL RESPONSE (V)</b>		
ORIENTED (ANSWERS TIME, PLACE, PERSON)	=	5
CONFUSED CONVERSATION (MAY BE DISORIENTED)	=	4
INAPPROPRIATE WORDS ("MOTHER," "YESTERDAY")	=	3
INCOMPREHENSIBLE SOUNDS (GROAN, MOAN, SCREAM)	=	2
NIL (NO VOCAL RESPONSE OR SOUNDS)	=	1

---

**NOTE:** The Glasgow coma score is the sum of the scores for E, M, and V. The total score can range from 3 to 15, with lower scores indicating deeper coma.

---



(5) Skull x-rays are unlikely to show evidence of intracranial hematoma in young adults. They may confirm a fracture of the skull, but such a fracture would be highly unlikely in someone who shows no bruises or other signs of a hard blow to the head. If there is significant evidence of a severe blow, with or without skull fracture, patients are evacuated to a hospital with neurosurgical capabilities.

**NOTE**

A problem with evacuation to a corps hospital is that soldiers are counted as a loss to their units. The personnel replacement system counts soldiers as a loss to their units as soon as they cross the division/corps boundary.

The system does not provide for returning soldiers to their old division, let alone their own platoon, unless such a return is individually coordinated according to the TSOP. If returned to combat in a strange unit, recovered BF or concussion cases, like all other soldiers, will for a time be at high risk for BF or injury. After intracranial hemorrhage has been ruled out at the hospital, transferring the soldier briefly to the CSC reconditioning center (see Chapter 9) may facilitate more selective RTD.

*h. Spinal Cord Trauma.* Pressure, bruising, and hematomas of the spinal cord, as well as severing of the spinal cord, can cause spinal shock, with loss of sensory and/or motor functions below the level of the injury in the affected dermatome and muscle group patterns. The loss of function may be bilateral, unilateral, or partial. These cases could be confused with paralysis or sensory-loss forms of BF. Further manipulation of a fractured spine can worsen or make permanent the spinal cord damage. Information from the history of onset, a cautious

physical and neurologic examination, or complete relief of symptoms following hypnosis or strong positive suggestions could demonstrate convincingly that this is only BF. It is best to be cautious and keep the spine immobile during care and transportation. Send the soldier to where adequate X rays can be done while still expressing optimism that this may be only temporary BF or spinal bruising.

*i. Postconcussion.* Postconcussion syndromes may persist weeks to months beyond the period of acute concussion. Postconcussion syndromes may include perceptual or cognitive impairment, poor impulse control, and difficulty in planning ahead. These are often accompanied by cranial nerve deficits or soft neurological signs. If severe and documented by examination or neuropsychological testing, this could weigh against rapid RTD. It may necessitate recommending reclassification and retraining to another duty.

**NOTE**

Like a concussion case, it is important to return cases who prove to have only BF to their original units if recovery at the CSC reconditioning center is rapid.

*j. Abdominal Trauma.* Ruptured spleen or other intraperitoneal bleeding may cause shock. The soldier may arrive in a fetal position and be unresponsive but with reflex "guarding" due to peritonitis. A case such as this was misdiagnosed as "catatonia" and sent to an Israeli mental health team in Lebanon as one of over twenty stress cases in a true mass casualty situation. The team checked the vital signs and correctly returned the soldier for emergency surgery.

*k. Air Emboli and Focal Brain Ischemia.* High blast overpressures from an incoming

high explosive ordnance can produce air emboli (bubbles in the blood) and focal brain ischemia (small areas in the brain which cannot get oxygen because the blood flow has been interrupted). Nuclear explosions can do this, as can high explosives when shock waves are magnified by reflection within bunkers, buildings, and trenches. A few cases die within seconds, perhaps with no other sign of injury, although ruptured eardrums, general trauma, and evidence of pulmonary damage should be detectable. More cases may survive but have stroke symptoms which could run the full range from loss of muscle strength and/or loss of sensation in parts of the body (hemiparesis, hemianesthesia) to mild or major speech disturbances, depending on the size, number, and location of bubbles that are lodged in the body.

(1) Some air emboli may leave areas of permanent brain cell destruction and disability. Other smaller ones may allow considerable or complete recovery of functions in minutes to weeks. This occurs if collateral circulation keeps the cells alive until the bubbles resorb or if neighboring areas of the brain relearn the function. However, even in those who have full and rapid recovery of brain functions, the symptoms may persist as the pure loss-of-functions type of BF. This would be because the soldier's extreme anxiety and internal conflict have been unconsciously relieved by his honorable status as a patient.

(2) Specific treatment, if air emboli are suspected from the history of onset and physical findings, is to assure the best feasible oxygenation of the brain.

1. *Laser Eye Injury.* Today's laser range finders/target designators cause small burns on the retina if they shine directly into the eye, even at great distances and especially if viewed through optics. The fact that lasers travel silently at the speed of light along a line of sight adds new urgency to the saying, "If you can be

seen, you can be hit." However, the second part of the saying, "If you can be hit, you can be killed," is not so true. The flashes of light the person sees may even warn him to take action to evade the missile or bullet that may follow. However, after laser eye injury has happened to several leaders or gunners in a unit or as rumors of it spread, other soldiers who must view the enemy may find their own vision failing for purely psychological reasons. Vision is one of mankind's primary means of relating to the world; it is used by those who have it in performing most tasks. Vision is also the medium for many pleasures. Fear of major degradation of visual acuity and especially total blindness is, therefore, an unusually strong fear. In the imagination of some soldiers, especially those whose careers, activities, and self-image depend on vision, blindness may rank high as a crippling wound which makes a person helpless and an object of pity.

(1) If the laser beam causes a small retinal blood vessel to bleed inside the eyeball, the person will see red. If blood inside the eye is confirmed on examination, these soldiers should be evacuated to a hospital with verbal reassurance that they may RTD soon. If the soldier is seeing red but no blood is confirmed on ophthalmoscopic examination, treat as BF.

(2) If the laser does not hit a blood vessel, the soldier may see only flashes of light, followed quickly by some painless loss of vision. If the damage is peripheral vision, the soldier may never know it. However, if he was looking exactly at the laser source, there will be major loss of visual clarity with no pain. These symptoms may resemble visual forms of BF.

(3) With simple retinal burns, most of the visual symptoms are due to the swelling around the very tiny burns. Much of the vision may recover within hours to days with rest, reassurance, and nonspecific treatment, the same as for BF. The only permanent result may be a

constellation of small black dots in the soldier's visual field or a peripheral visual field defect of which the soldier is unaware.

(4) Treatment following a suspected laser injury is extremely important. Calm, professional treatment at each echelon of medical care is mandatory. Assurance that the injury is not life threatening and that chances for some, if not total, recovery is good. The potential psychological effects of lasers could be enormous. It is imperative that secondary gain for these patient be minimized. This is accomplished by prompt RTD of those individuals with temporary flash-blindness, noncritical (nonfoveal) burns of the retina without hemorrhage, and those who are experiencing purely psychogenic visual loss. If an error is to be made, it should be to RTD questionable injuries, provided the risks are minimal for further injury or accident. Medical management of stress reactions for patients suffering from real or imagined laser injuries is like stress management of other injuries. Repeat the reassurance that symptoms will improve with rest, nutrition, hygiene, and the expectation of an early return to the soldier's unit.

(5) Future development of lasers as deliberate antipersonnel weapons may produce more pain and permanent effects. A high-energy laser weapon could cause the unprotected eye to boil and burst. It could cause burns to exposed skin and set clothes on fire. This would be a considerably more fearsome weapon, although one which makes differential diagnosis of real from psychogenic injury much easier. If these are encountered as a surprise, without adequate preparation and training of the troops, the psychological impact will be magnified. That may produce more cases of BF, some with visual symptoms. Laser-protective eyewear has been fielded; getting soldiers to wear it is an important issue for command and NCO emphasis.

(6) For more information on the threat of laser to the eye, see FM 8-50.

*m. Middle Ear Injuries/Diseases.* Temporary loss of hearing can be caused by a decreased acoustic sensitivity following a brief extremely intense noise (explosive) or less intense, longer duration noise. Tinnitus (ringing in the ears) can also result from acoustic nerve damage or irritation as well as from high doses of drugs, such as aspirin. Hearing loss or perceiving noises in the ears can also be BF symptoms. Cumulatively, loud noise causes permanent damage to the cochlea, resulting in hearing loss especially for the higher frequencies. This is why routine use of earplugs and ear covers in noisy situations is so important for many (if not all) military occupations. However, there are other combat situations where acute hearing is essential and earplugs cannot be worn. Distinguishing physiologic from psychogenic hearing loss may require that the patient be evaluated by an otolaryngologist (ear, nose and throat specialist).

*n. Peripheral Neuropathies.* These include compression neuropathies which are especially likely in military settings (for example, rucksack palsy). Depending on severity, they may require temporary job reclassification during convalescence. As they are not life threatening, a hasty diagnosis should not precede a trial of restoration treatment.

*o. Uncommon but Endemic Neurologic Disorders.* These are physical diseases whose symptoms (at least initially) are primarily mental or behavioral (although eventually documentable by neurological or laboratory examination). Examples include:

(1) Guillain-Barre syndrome (muscle paralysis, usually without sensory loss, which ascends the legs and arms, then the trunk, over hours to days). It is sometimes triggered by immunizations, as might be given to troops deploying overseas. It often progresses to a life-threatening situation as the muscles of respiration become involved. This requires evacuation

to COMMZ and CONUS. Fortunately, recovery is usually complete, but it takes months to years.

(2) Multiple sclerosis. This disease can mimic many types of BF with its sometimes transitory, shifting motor, sensory, speech, and cognitive/emotional symptoms. It is made worse by stress and may be difficult to diagnose. Once confirmed, true multiple sclerosis cases should be evacuated to CONUS, as should other rare, progressive diseases like Lou Gehrig's disease (amyotrophic lateral sclerosis). Multiple sclerosis on the battlefield is not likely to be more common than in any other population of young to middle-aged adults.

(3) True convulsive seizure disorders. This may be a rare sequela of prior RTD head injury or a common sequela of sublethal or chronic nerve agent exposure. These are treated with the normal anticonvulsant medications. If soldiers who are anxious about nerve agent attack observe someone having a seizure, that may trigger an epidemic of purely psychogenic seizures. Pseudoseizure (becoming unconscious, falling down, and shaking all over) sometimes occurs as a BF symptom. The extremely anxious soldiers may also have urinal and fecal incontinence during the pseudo seizure, as loss of bladder and bowel control at times of extreme danger is common. In a civilian setting, incontinence during pseudoseizure is unusual.

*P. Substance Misuse/Abuse.* These may be examples of misconduct combat stress behaviors but are not necessarily reactions to combat stress. Drug and alcohol abuse are epidemic in US civilian society, especially among adolescents and young adults, and continue to be a problem in the Army in spite of prevention programs.

(1) Heavy habitual use of alcohol, even by otherwise capable officers and NCOs, may go unnoticed in peacetime. However, it may

degrade the increased levels of mission performance demanded by combat or may result in withdrawal symptoms when access to alcohol is interrupted by deployment. Minor alcohol withdrawal is identical to the normal common signs of BF and requires no special treatment. However, it is important to prevent the onset of major alcohol withdrawal if the history or physical findings of chronic heavy drinking suggest that is likely.

(2) Intoxication or withdrawal from alcohol, barbiturates, and tranquilizers may be mistaken for BF; however, these conditions require special treatment. Withdrawal seizures or impending or ongoing delirium tremens need emergency treatment with diazepam, another benzodiazepine, or phenobarbital to stabilize for evacuation and detoxification in a corps hospital. Dosage will be determined by the treating physician.

(3) Overuse of stimulants (such as deliberate abuse or the desire to stay alert) may cause panic attacks, manic hyperactivity, rage attacks, or a condition which closely mimics acute paranoid schizophrenia. Those patients with paranoid psychosis can be treated with standard antipsychotic drugs such as chlorpromazine or haloperidol but may take 7 to 10 days to fully recover. Cessation of amphetamines after prolonged use causes a "crash" (extreme sleepiness, lethargy, overeating) and perhaps even a "crash and burn" with possible serious depression and suicidal thinking. This condition may require 1 to 2 weeks of hospitalization to assure safe recovery,

(4) Hallucinogenic drugs cause sensory distortion, panic, bizarre thoughts, and potentially dangerous actions. These may be employed by the enemy as chemical or biological warfare agents. Phencyclidine hydrochloride (PCP) is especially problematic since it also blocks pain and tends to make those under its influence paranoid, violent, and abnormally strong.

Hallucinogenic drug psychosis should not be treated with antipsychotic drugs. Physically restrain, sedate with diazepam or lorazepam, if necessary, and evacuate for stabilization and further evaluation.

(5) Inhalation of fumes (either by accident or as deliberate abuse) and carbon-monoxide poisoning can cause disoriented, abnormal behavior. Supportive treatment and, in cases such as carbon monoxide poisoning, specific antidotes or medication may be needed.

*q. Anticholinergic Delirium.* In combat, atropine may be a problem since we equip our troops with atropine injectors to use as first aid against nerve agents. Even 2 milligrams (mg) (one atropine injector) without nerve agent challenge can cause rapid pulse, dry mouth, slightly dilated pupils, decreased sweating (hot, dry, flushed skin), and perhaps urinary retention. In some individuals, 6 mg of atropine (equal to three atropine injectors) may cause hallucination and disorientation (without a nerve agent challenge). Such effects may be more common in sleep-deprived soldiers. Similar effects can also occur from eating certain plants. When soldiers are heat-stressed from exercise, clothing, or exposure to hot, desert, or tropical environments, doses of atropine tolerated well in temperate climates may be even more incapacitating. In the heat-stressed individuals, doses of atropine tolerated well in temperate climates may be seriously incapacitating by degrading the sweating mechanism. Such situations can sharply reduce the combat effectiveness of troops who have suffered little or no exposure to a nerve agent. One dose (2 mg) of atropine can reduce the efficiency of heat-stressed soldiers. Two doses (4 mg) will sharply reduce combat efficiency, and 6 mg will incapacitate troops for several hours.

(1) Stabilization is achieved through reassurance, physical restraints (if require for combative behavior), and supportive

treatment (fluids, cooling). These measures will sustain the soldier until the atropine is cleared in 6 to 18 hours. Do not give chlorpromazine or diphenhydramine as they make the condition worse. Diazepam may be used if sedation is essential. In hot, humid climates, individuals who have inadvertently taken an overdose of atropine and are exhibiting signs of atropine intoxication should have their activity restricted. In addition, these casualties must be kept as cool as possible for 6 to 8 hours after injection to avoid serious incapacitation. Usually, the casualties will recover fully in 24 hours or less from a significant overdose of atropine.

(2) Physostigmine (a rapidly cleared antinerve agent) is the specific antidote for atropine; it must be titrated carefully over hours to avoid overdose or relapse. This may be impractical in mass casualty situations. If available, it can be used to confirm the diagnosis. Physostigmine needs to be given in repeated doses only to those relatively few cases of atropine overdose who are in danger of death from excessive body temperature (heatstroke) or cardiovascular collapse due to the high pulse rate.

*r. Anticholinesterases.* Nerve agent is an anticholinesterase similar to many insecticides. Low-dose nerve agent exposure may produce miosis (pinpoint pupils) without other signs; this will seriously decrease vision except in very bright light and cause eye pain when attempting to focus. This may take hours to days to improve spontaneously, depending on the degree and type of exposure. Giving atropine eye drops will only relieve the spasm if the soldier has been taking pyridostigmine as a pretreatment; the soldier will then have several hours with very large pupils (bothered by bright light) and will have difficulty focusing on near objects, especially fine details. Evidence gathered from affected insecticide workers suggests that mild personality changes, insomnia with bad dreams, and chronic persistent depressive symptoms (similar to common BF) may

be seen even after use of an antidote. Low-dose nerve agent exposure may lower the seizure threshold of many soldiers. True epileptic seizure cases must be distinguished from those soldiers who may have pseudoseizures and need only treatment for BF.

s. *Endemic "Functional" Major Psychiatric Disorders.* These (especially schizophreniform/schizophrenic disorder, major depression, and bipolar disorder) will continue to occur at approximately the same rate as in peacetime Active and Reserve Component personnel. They should be evacuated to CONUS as soon as they can be distinguished from temporary BF or substance-related conditions with good potential for RTD. However, that cannot be accomplished without some period of observation which approximates the doctrinal restoration treatment for BF. That stabilization must be conducted in a sufficiently secure, structured setting that assures safety for violent or self-destructive behavior. A few soldiers who have been diagnosed with psychiatric disorders by a civilian physician may deploy to the theater. These soldiers may hide the fact that they are taking psychotherapeutic medication to keep the diagnosis off their military record. Once in the theater they may experience a relapse or self-refer themselves to an MTF when their medication supply is exhausted. The evaluating psychiatrist must determine if the soldier can function without the medication. If the soldier requires medication, can he be restabilized on a drug which can be provided in the theater? Can the drug be given without risk of harmful side effects? If the alternatives are not feasible, the soldier must be evacuated out of the theater. The following guidelines are proposed for management of cases with significant symptoms that suggest a major psychiatric disorder:

(1) *Severe retarded or agitated depression with suicidal preoccupation.*

- Survival guilt is common with BF, as are feelings that death would be a relief, would end the suspense, and is so likely that it should be expected. Such cases are unlikely to commit suicide but may fail to take adequate precautions for safety. They may be safer with trusted comrades who can watch out for them (as DUTY BF) than with an unfamiliar CSS unit and categorized as REST BF. If they cannot be held in their own unit, they should be triaged as HOLD rather than REST unless the CSS unit where they are attached can provide close supervision.

- Sleep loss, emotional and physical fatigue with apathy, and loss of appetite can mimic retarded depression. However, the soldier should regain energy, appetite, and perspective quickly with sleep, hygiene, and good A rations.

- Significant anxiety on top of the depression could mimic a severe agitated depression but should also improve quickly with rest in a relatively safe place.

- Serious suicidal intent is more likely in soldiers who have suffered severe disappointment on the home front (Dear John letters) or who have, in fact, committed errors about which they have reason to feel guilty (such as accidental fratricide). While such cases should be treated as BF, special attention should be given to ensure their safety and to work on the underlying problem. Cases with depressive symptoms which do not improve in 1 to 3 days go for 7 to 14 days of reconditioning. Brief hospitalization on the CSH's NP ward with suicide precautions may be necessary for those who are judged dangerously suicidal. If the depression has not improved after being sent for reconditioning in the COMMZ, these cases meet the *Diagnostic and Statistical Manual of Mental Disorders*, Third Edition, Revised (DSM III-R) criterion for major depression (2-weeks duration).

(2) *Predominantly auditory verbal hallucinations and schizophrenic-type thought disorder.*

- This could be due to stimulant misuse in a good soldier or a brief reactive BF in response to extreme stress. This is not a condition which can be managed in a 1- to 3-day restoration program without excessive disruption for the other BF soldiers. The potential risk of an open environment with many loaded firearms is too great. Send this case to a hospital with NP staff for stabilization. If symptoms improve quickly with rest or with anti-psychotic medications, transfer the soldier forward to the reconditioning center to prepare for RTD. If psychotic symptoms persist, evacuate to the COMMZ and CONUS.

- Auditory but nonverbal hallucinations (such as hearing battle sounds, perhaps also with visual hallucination of battle sights) are more likely to be BF with potential for limited RTD in the TO.

(3) *Paranoid delusions without formal thought disorder.* If this follows severe sleep loss, it may clear completely with reassurance and sleep. If it does not, consider the nature of the delusion and the sociocultural context. Is it likely to interfere with mission performance and/or could it lead to inappropriate violent behavior? If yes, HOLD or REFER (evacuate) for further evaluation. If no, RTD with appropriate advice to command or comrades about how to handle to get best performance.

(4) *Manic episode.* This could be due to sleep loss and stress, stimulant misuse, or bipolar disorder. The soldier may be too disruptive to keep at forward locations. If sedations (with physical restraint, if necessary) result in improvement after good sleep, consider RTD. If mania persists, evacuate to next echelon for further evaluation.

t. *Endemic Personality Disorders.*

Preexisting personality disorders may make a soldier unable to adapt to military life. However, numerous studies have failed to show a relationship between personality disorders and the likelihood of breakdown in combat. Even so, once soldiers with personality disorders have become BF casualties, they may have greater difficulty recovering and returning to duty. Those who malingering (deliberately fake illness to avoid duty) must be detected and RTD or have administrative action initiated by the unit.

(1) A documented (DSM III-R) personality disorder which also interferes with the soldier's ability to perform duty is a basis for administrative discharge (Chapter 5, AR 635-200). The responsibility of the evaluating psychiatrist or psychologist is to certify that the soldier's unacceptable behavior is part of a true personality disorder. This is measured by DSM III-R's strict criteria, specifically—

- It is part of a long-standing pattern that has been evident since childhood or early adolescence.

- It is present in other aspects of the soldier's life besides military duties.

- It is inflexible and has not changed in spite of reasonable efforts to correct it.

- It interferes with military duty.

This diagnosis may not be appropriate for someone who is still in adolescence, as may be the case with some basic trainees and first tour soldiers. The lifelong label of a personality disorder as explanation for military discharge must not be applied unless all of the features are present, even though the soldier himself, as well as the commander, may wish to take this easy way out.

(2) In the CZ, it may be difficult to get the long-term occupational and social history needed to truly document that a soldier's behavior is due to a personality disorder and not just to BF or an adjustment disorder. In principle, soldiers should not be medically evacuated from the theater for poor performance or misconduct. If the soldier's emotional or mental state does preclude return to useful duty and command

insists on rapid evacuation, the diagnosis of personality disorder (and recommendation for chapter discharge ) may best be deferred for further evaluation in CONUS. In the CZ, command should be unwilling to allow so easy a way home which might encourage malingering. They should require RTD, job reclassification, or disciplinary action, unless true BF is present and does not respond sufficiently to treatment.



## CHAPTER 7

## COMBAT STRESS CONTROL STABILIZATION

**7-1. Priority for Stabilization**

Combat stress control stabilization is the acute management of the small percentage of BF and NP cases who have severe behavioral disturbances. The behavior seriously disrupts the functioning of the unit and may even pose a danger to the soldier or others. In some cases, the underlying medical condition may also be a danger to the soldier's life. Combat stress control stabilization can be divided into initial emergency stabilization and full stabilization.

*a. Initial Emergency Combat Stress Control Stabilization.* Initial emergency CSC stabilization has been achieved when the disturbed soldier is in physical restraints, can be given an adequate physical examination, and may, if necessary, be sedated for evacuation. This may be all that can be done at forward echelons by nonpsychiatric personnel or by CSC personnel in a mass casualty situation. Stabilizing severely disturbed soldiers will always have an extremely high priority, especially when they become agitated or combative. Such cases can cause serious harm to others as well as to themselves, especially in a presence of loaded firearms, explosives, powerful machinery, and life or death missions.

(1) Violent behavior is quite rare in pure BF but is one form of misconduct stress behavior. Some NP disorders are prone to violence, especially paranoid psychotic states. Violence is also more likely with disruption of brain functioning due to organic factors such as intoxication, hyperthermia, or metabolic imbalance.

(2) Increased numbers of these severe BF cases can be expected during high NBC threat situations. This is due to increased organic brain syndromes caused by antidotes (such as atropine), heat stress, the heightened

physiological stress, and the possibility of direct NP effects of some NBC agents.

(3) Examples of these CSC casualties requiring immediate stabilization were provided in paragraph 6-3.

*b. Full Stabilization.* Full stabilization goes beyond securing the safety of the patient and those around him. It prepares the patient for an evaluation of his potential for RTD in the near future. If RTD within the evacuation policy is not feasible, it prepares the patient for safe, long-distance evacuation. Full stabilization is normally the responsibility of the NP ward and consultation service (module of the hospital unit base) in every CSH, FH, and GH.

(1) Full stabilization is desirable for the sake of the soldier's future treatment and for the potential of returning some soldiers to duty. However, full stabilization is personnel intensive with a relatively low RTD payoff. For that reason, full stabilization has the lowest priority of the six CSC functions. Providing only sufficient initial stabilization to allow evacuation from the theater may be accepted in order to maintain the other CSC functions.

(2) However, because of the low priority for evacuation of NP patients as compared to the large surgical caseload, it is quite likely that NP patients will accumulate in the CZ or COMMZ. Even adequate initial stabilization will require continued resources.

**7-2. Use of Restraints in Initial (Emergency) Stabilization**

*a. Physical Restraints.* Physically restraining soldiers with presumed BF goes against the treatment message of normality and positive expectation. However, some NP and a few BF cases may be—

- fused.
- Seriously disoriented and confused.
  - Paranoid.
  - Delusional.
  - Hallucinatory.
  - Suicidal.
  - Agitated and restless.
  - Manic and intrusive.
  - Threatening violence.

Restraining these soldiers may be necessary to ensure safety of the soldier and other personnel. Physical restraints also minimize disruptions of medical or restoration activities (especially when staff are few). It also permits medical evacuation by ground (preferred) or air ambulance.

*b. Subduing and Restraining an Agitated or Disruptive Soldier.* The best way to subdue and restrain agitated or disruptive soldiers is verbally, by reassurance and re-orientation. If that fails, a nonthreatening show of strength may suffice. Otherwise, decisive coordinated action by five helpers, one on each limb, one to hold the head, is preferred to get the soldier face down on the ground. More helpers get in each other's way. Fewer may be all that are available but risk more injury to the staff from bites, blows, or kicks. The patient also is more likely to be injured. It is inadvisable to attempt subduing an agitated case one-on-one. The restraining team should continue to talk with and provide reassurance to the resisting patient during the take-down.

*c. Methods of Restraining.* Once the soldier is face down, mechanical restraints can be applied if sufficient personnel are available.

Lockable, padded leather cuff restraints are safest but may be in short supply. Other methods such as using two litters (sandwiching the patient between the litters and using straps for securing) or straps, sheets, improvised strait-jackets or any other field expedients may be used. Regardless of the method, the soldier placed in restraints must be checked frequently. This is done to guard against nerve injuries or impaired circulation leading to skin ulcers or gangrene. It is also important to check that the soldier is not secretly escaping from restraints. The soldier is provided verbal reassurances with positive expectations for his recovery each time he is checked.

### 7-3. Use of Medication in Initial (Emergency) Stabilization

*a. Administering Medication.* Administering medication to an uncooperative and unrestrained severe BF soldier can be extremely difficult; unfortunately, the effects of the medication may act too slowly to be much help. Once the soldier is in restraints, the medication is no longer essential and serves mainly to reduce the risk of escape. Medications will reduce an agitated soldier's resistance to the restraints, thus diminishing the disturbance of other BF soldiers in the vicinity.

*b. Observing for Reactions.* The soldier is observed for any reactions. Be concerned that the medication does not interact badly with any biochemical already present in the disturbed soldier. Do not give chlorpromazine for anticholinergic delirium. If hallucinogenic drug intoxication is suspected, the use of any antipsychotic drug is contraindicated. The use of diazepam for pathological intoxication with alcohol or barbiturates is also contraindicated.

*c. Rapid Sedation.* Rapid sedation with antipsychotic drugs (repeating high doses every half hour until the patient is sedated) was

widely practiced in the early 1980s. This method did not improve overall recovery time significantly and did tend to cause more side effects such as dystonic spasms of the neck, back, or eye muscles. Now, even in known psychiatric patients who must be restabilized after stopping their previously successful medication, it is more common practice to build up antipsychotic drugs gradually. To achieve an antianxiety and sedative effect, the patient is initially treated with a benzodiazepine (such as diazepam or lorazepam). Lorazepam, if available, has the advantage of being more consistent when given intramuscularly.

*d. Effects of Antipsychotic Drugs.* Antipsychotic drugs can take several hours to days to take effect. Early administration of chlorpromazine or another antipsychotic drug may confuse the clinical picture for the next evaluator if the soldier is evacuated. The evaluator will not know whether any changes in the soldier's behavior over the next day or two was due to the reassurance, sleep, hydration, and reduced anxiety (from increasing distance from the battle), or whether it is just due to the medication. The medication must be discontinued if the soldier is to RTD. Therefore, the recommendation for most cases is to use no medication unless it is truly necessary for management. If medication is required, use as low a dose as is effective of a benzodiazepine (usually diazepam or lorazepam, although a shorter acting benzodiazepine, such as temazepam, would be better when available).

#### 7-4. Full Stabilization in Combat Stress Control

Full stabilization in CSC includes adequate evaluation of RTD potential. This requires assessment of mental status and performance capability over time without excessive drug effects or limitations on activity. Contact with the soldier's unit may

be needed to get information on prior history and functioning. The further from the unit the soldier has been evacuated, the more difficult it is to contact the soldier's unit. Full stabilization normally takes several days.

*a. Follow the Principles for Treating Battle Fatigue.* To the extent compatible with safety, the stabilization program should adhere to the principles and methods for treating battle fatigue:

##### (1) PIES:

- Proximity to the soldier's unit.
- Immediate initiation of treatment.
- Expectation of rapid and full recovery.
- Simplicity of approach.

##### (2) The four Rs:

- Reassurance of normality.
- Rest.
- Replenishment of nutrition, hydration, hygiene, and sense of physical well-being.
- Restoration of confidence through talk and activities.

(3) Maintain and reinforce the soldier's identity as a soldier.

- Battle-dress uniform, not pajamas, as soon as they can be allowed safely.
- Rank distinctions and appropriate military courtesy.

- Responsible for self-care and helping others.

b. *Evaluation and Treatment Modalities.* The evaluation and treatment modalities include—

- Individual interviews for obtaining complete medical history.
- Mental status examination.
- Laboratory and x-ray workup, as indicated.
- Physical examination (should be thorough).
- Specialty consultations as indicated.
- Group sessions.
- Recreational activities.
- Occupational (work) history.

### 7-5. Stabilization Treatment Facilities

*Stabilization Facilities.* Ideally, stabilization is conducted by qualified mental health personnel in a nonhospital (medical company clearing station ) military setting, to maximize positive expectation and minimize chronicity. However, it must be kept separate from the restoration or reconditioning facilities, as the presence of these dramatically symptomatic soldiers is very disruptive to the treatment of BF casualties. More sophisticated procedures and laboratory and x-ray capabilities may be required than is available at medical company clearing station (for example, lumbar puncture and cerebral spinal fluid examination and analysis).

For that reason, most full stabilization will be conducted in the CSH, FH, or GH. All of these hospitals have an inpatient psychiatric capability. Those soldiers who improve and have the potential for RTD are then transferred to a reconditioning program.

b. *Neuropsychiatric Ward.* Military hospital NP wards in the TO can be categorized as either in fixed/planned facilities, fixed/improvised facilities, or mobile facilities.

(1) Fixed/planned facilities are in buildings which were designed or premodified to serve as psychiatric wards. These could be in US Army fixed hospitals, allied military hospital, or host-nation civilian hospitals. Depending on degree of modernity and enlightenment of psychiatric treatment, these should provide—

- Security design for protection against suicide.
- Seclusion areas.
- Comfortable and reasonably civilized surroundings.

These can provide the safest setting for initial stabilization, or for holding cases until they can be evacuated. They may already be divided into maximum security closed wards and open wards which allow for more responsible self-controlling behavior. If such facilities are to be used for the treatment and evaluation of soldiers for possible RTD, it requires steps to maintain a military setting for the wards and the treatment routine.

(2) Fixed/improvised facilities are in buildings which were not designed or previously modified for use as psychiatric wards. These buildings have been taken over for this purpose. They will require assessment and usually some modification to make them safe, including—

- Impassable screens on the windows.
- Covering of electrical outlets.
- Removal of hazard for suicidal or violent acting out.

Separation of wards into closed and open is desirable if layout and staffing allows. Here, too, it is important to maintain a military environment and routine to the degree patient safety allows, especially on the open ward.

(3) Mobile facilities are those which are in tent, extendable, modular, personnel (TEMPER) or general purpose (GP) large tents. The principal advantage of the (hospital) TEMPER tents, as assembled into Deployable Medical System (DEPMEDS) hospitals, is their climate control capability. This may be a significant safety advantage for treating seriously disturbed patients in restraints with high-dose medication, which can disrupt normal thermal regulations. Both TEMPER and standard tents pose greater problems for security than do fixed facilities. The staff may, therefore, have to rely more than is ideal on physical and/or chemical restraints. Blankets or screens can be used to isolate or segregate problem patients from others. Such partitions reduce behavioral contagion but provide little true protection. Standard mobile hospital beds on high, lightweight metal legs must be replaced with standard low, stable cots to hold strong, agitated patients in restraints. The cots also make a more “military” setting and can be used as seats for group activities. As in the fixed facilities, it is best to have a separate “closed”

(high security) and “open” (moderate/minimal security area. The latter could be a standard GP large tent (the same as those of the minimal care wards [MCW]) located close to the TEMPER tent of the official NP ward. The specialists (MOS 91C and 91B) of the MCW could be given on-the-job-training in supervision and military group activities for the moderate/minimum security cases if the NP staff is too small.

c. *Mixed Neuropsychiatric/Medical Surgical Ward.* The NP ward may be expected to admit those NP cases with concurrent physical illness or injury and concurrent significant mental symptoms unless the patient’s condition requires that he be in the intensive care unit, or in isolation because of contagious disease. The mental symptoms could be—

- Caused by organic brain disruption (such as drug intoxication or withdrawal).
- Functional NP disorders which are coincidental to the illness or injury.
- Functional and in reaction to the traumatic situation which caused the injury.

The NP staff must be prepared to react therapeutically whatever the cause of the disturbed behavior. In the event of many medical/surgical cases, the NP ward could receive overflow medical/surgical cases. Therefore, NP ward staff must remain current in basic nursing and wound care skills.

d. *Combat Support Hospital Neuropsychiatric Ward Staff.* Definitive information is provided on the CSH NP ward staff capabilities in FM 8-10-14.

## CHAPTER 8

## COMBAT STRESS CONTROL RESTORATION

**8-1. Restoration of Battle Fatigue Casualties**

*a. Restoration.* Restoration is the 1-to 3-day treatment of BF casualties at medical units which are as close to the BF casualties' units as their condition and the tactical situation allow. Restoration can be divided into first line (the furthest forward, with few staff, under very limiting and fluctuating conditions), second line (still limited, but with more expert staff and more predictability) and third line (performed at Echelon III or Echelon IV hospital).

*b. Screening and Treatment.* Adequate medical screening and treatment must be done in the supported units by organic medical platoons or by the supporting medical companies. The BF casualties who enter restoration should be only those HOLD and REFER cases who require continuous medical and/or mental health evaluation and observation for 24 hours or more. Although still on their unit roll, they are not available to that unit for even limited duty and are, therefore, true casualties. DUTY (mild) cases will have been returned to their small units and REST (moderate) cases sent to rest in their units' CSS elements.

*c. Restoration Priority.* Restoration usually has the fifth priority following consultation, reconstitution support, combat NP triage, and minimal essential stabilization. However, when true BF casualties are numerous, or when the tactical situation makes it difficult for forward units to manage DUTY and REST BF cases, the influx of BF cases may force restoration to take a temporarily higher priority.

(1) To the maximum extent possible, restoration should be increased. This means a lower priority for reconditioning and stabilization being restricted to the minimum

requirements for cases and unit safety while awaiting (and during) evacuation.

(2) To the greatest extent possible, preventive consultation, operational planning and RTD-related coordination must continue or the influx will worsen!

(3) Combat stress control personnel should be freed up for reconstitution support missions even if that means evacuating some BF casualties who appear likely to require disproportionate effort for restoration. Otherwise, more BF soldiers who could have recovered and returned to duty in their units will just add to the already great work load for restoration.

*d. Categories of Restoration.* Restoration can be categorized as first line, second line, or third line, depending on where it is provided. The three categories may also differ in duration of restoration which they usually provide. This is dependent on the level of specialized skill, experience, and knowledge of the providers.

**8-2. Generic Tactics, Techniques, and Procedures of Restoration**

*a. Reprieve from Extreme Stress.* Initial restoration begins at the most forward echelon where the label "REFER BF" can be changed to "HOLD." Normally, restoration facilities are part of (or collocate with) the clearing station of the supporting medical company.

(1) Criteria for when to hold cases for restoration were discussed under combat NP triage in Chapter 6.

(2) Restoration is not feasible at locations which are consistently under artillery.

air, or direct-fire attack, unless they are exceedingly well fortified and resistant to damage. However, safety on the modern deep battlefield is never complete; relative security is sufficient to provide restoration. If there is potential for attack, there should be reasonable cover and defensive position to provide a sense of relative safety to a jumpy combat soldier. A good work detail for recovering BF casualties is the digging, building, and camouflaging of these positions.

(3) Ideally, the location is still “within sound of the artillery,” that is, within the sounds of the distant booms or rumble that remind the soldier that comrades are still in battle. Other relatively distant noises, such as helicopters, aircraft taking off, or road traffic, are also acceptable provided they are not so noisy as to disrupt sleep.

(4) In addition, the location should not be one from which a move is likely within 24 (or 48) hours. If there is a significant possibility of a move, only those cases who can participate actively in the move with minimal supervision should be held for treatment at this location. Any time the unit is given a warning order to standby to displace, the CSC staff may have to conduct a quick sorting of the cases on hand. The staff uses more stringent combat NP triage criteria and sends to the next-line restoration facility all those who are not readily transportable with the team.

(5) The specific site of the restoration facility should be out of immediate (close) sight of the triage area. Battle fatigue casualties should not be able to see severely wounded soldiers come into the MTF. The expectant area or temporary morgue areas, when mass casualty situations occur, should also not be seen from the restoration facility. It may be close to, but ideally slightly separate from, the treatment area for RTD wounded and DNBI cases. However, these can merge if provision is made to stabilize overly dramatic cases elsewhere. Ideally, the restoration

area is close to the host unit’s field kitchen and other support facilities.

(6) Restoration facilities collocated with medical units in the BSAs and DSAs will often be restricted by the local commander from displaying the red cross on the grounds that it reveals the entire unit’s location. This is consistent with the principle of treating BF cases as “soldiers, not patients.” In the corps area, there is a greater chance that the medical unit will be allowed to display the red cross. The restoration (and/or reconditioning) facility leader will need guidance on whether to display the red cross or not. If the red cross is displayed, there is greater assurance of protection under the Geneva Conventions. For discussion of the issue of Geneva Conventions status and its limitations on CSC activities, see Appendix D.

*b. Reassurance.* Restoration begins after the initial combat NP triage evaluation described in Chapter 6. Immediate reassurance is given to BF soldiers,

(1) Tell them that they are temporarily joining the unit, not as patients, but as soldiers who need a couple days to recover from BF. Emphasize that BF is a normal response to extremely abnormal conditions and that rapid recovery is also normal.

(2) Orient the BF casualty to the program. Tell them that they will get plenty of food and beverages, good sleep, a chance to clean up, and light duties for 1 or 2 days (or at most, 3 days). By that time, they will have regained strength and confidence and will return to their unit.

(3) Reassure them (as much as you honestly can) about safety and what to do in the event of an attack or march order.

(4) Personal possessions are not taken away. These personal items remind the

soldiers of their normal lives and are a comfort in time of stress. The soldiers are expected to take care of their personal items. This applies even to knives or other weapons (with the exception of firearms), unless there is significant reason for concern that this soldier might harm himself or others. Soldiers for whom there is such concerns need stabilization and should be segregated, at least temporarily, from the restoration program.

(5) If the soldier arrives with a firearm, the weapon is secured by the medical company supply element. Ammunition, grenades, mines, or other explosives must also be collected and turned-in. The soldier should be told that this is the TSOP for all medical units. Tell the BF soldier that his weapon will be returned to him if he is assigned guard duty or if the medical unit is under the threat of an attack.

c. *Structured Military Environment.* Maintain a structured military chain of command. When the BF soldier is processed into the restoration program, he is received as a soldier performing temporary duty and not as a patient.

(1) Assign the BF casualty to a “squad” under supervision of a specific squad leader. At larger facilities, several squads may be organized into a platoon, under a platoon leader. In an extremely large restoration center, several platoons could be organized into a company. The squad leader may be a CSC unit or mental health section officer, NCO, or section member, or a member of the host medical unit’s patient-holding squad. In a pinch, a carefully selected line NCO with a minor wound or injury that temporarily prevents his RTD may be detailed as a squad leader. Ideally, each squad leader should not have more than 6 to 8 BF casualties to supervise. For brief peak periods, the squad leader may be assigned 10 to 12 BF casualties to manage.

(2) The soldier’s FMC (filled out during combat NP triage) is not kept attached to

the soldiers, but is kept at a central place until the soldier is ready to RTD or be evacuated.

(3) The initial interview and activities depend upon the symptoms of the BF casualty and the degree of physical/psychologic stress in relation to the cognitive/emotional stress. The attitude of the interviewer should be that of a good, caring leader. As a leader, he is getting to know the recent experience, background, and skills of a new soldier just assigned to his unit as a combat transfer, not as a therapist doing an intake interview.

- A BF casualty who is in good physiologic shape, but who clearly has much to talk about, should be encouraged to talk immediately.

- More often tending to and restoring physiologic status comes first. The order of priority varies with the nature of the deprivation.

(4) The newly arrived soldier is not assigned to a ward tent as a patient but rather to the squad’s quarters tent. In many situations, it will be appropriate and necessary for the squad leader(s) to sleep in the same tent with the team members. Ponchos or blankets can be hung to screen off areas where true patients are resting and to provide privacy.

d. *Replenishment of Physiologic Status.*

(1) Restore temperature regulation. Get the soldier under shelter and cool down if overheated, warm up if cold, dry off if wet.

(2) Replenish hydration with palatable beverages (cool if hot, warm or hot if cold).

- Soups are ideal as they are also foods.



- Milk, soft drinks, Kool-Aid, and fruit juices are good.

- Minimize caffeine-type stimulants in coffee, tea, or beverages, unless increased wakefulness is desired.

- Intravenous fluids may be used in exceptional cases when speed of dehydration is important. Effort is then required to reinforce the fact that the soldier is not a patient and that this is just routine.

(3) Replenish nutrition. Offer the best possible filling meal, preferably high in carbohydrates with some protein.

(a) A-rations from the host unit's field kitchen are best. Hot tray-packs (especially the noodles and potatoes tray) and even hot MREs are acceptable. If the latter are used, try to have some special seasonings or garnishes to increase variety and palatability. Break up and stir most tray-pack selections to normalize their texture and appearance, rather than serving them as a solid rectangular "brick."

(b) Since BF casualties may arrive at any time, day or night, a restoration facility must have means to quickly heat food. The minimum standard is a large pot of water ready to boil at all times. If the supporting field kitchen cannot provide this, CSC personnel should coordinate for other arrangements.

(c) If a BF casualty is too tired, anxious, or depressed to eat at first, provide an assigned area for sleeping. "Three hots and a cot" are essential throughout the period of restoration.

(4) Restore hygiene. Unless the soldier is totally exhausted and already falling asleep, institute some personal hygiene.

(a) Wash face and hands with wash cloth, warm/hot water and soap. The men shave with hot water, soap or lather, and sharp safety razors. This may extend to a partial or full sponge bath, if feasible. The restoration facility needs a supply of sundry packs plus a basin.

(b) Hot showers, if available. A quartermaster shower/bath unit may be present in a corps base defense cluster DSA or BSA. The shower point may be some walking or riding distance away, and scheduled hours of operations should be considered.

(c) In hot or temperate weather, CSC personnel (and/or the host medical unit) should set up a field shower.

- This could be an Australian shower bucket, a collapsing canvas bucket with nozzle. A shower could be improvised by perforating other large buckets or 55-gallon drums (see FM 21-10).

- The shower can be screened with poncho liners for privacy and given a wooden pallet "floor" above the water run-off. In cold weather, a tent with a heater would need to be dedicated to the shower.

- Hot water from the field kitchen or an alternate source is blended with cool water to give a suitable shower temperature. Dry, clean towels are also necessary, since most of the BF casualties will not bring their own.

- The hot shower is an excellent way for new arrivals to relax and unwind before sleep, if they are not already too exhausted, or if harsh weather does not make it too difficult. Otherwise, it can be an "event" or "duty activity" for subsequent restoration days.

(d) The importance of clean clothes (if available) depends on the condition of

(how wet, sweaty, filthy, bloody, or torn) the BF casualties' own battle-dress uniforms.

- In principle, BF casualties should remain in combat uniform which includes helmet and protective mask. Reasonably complete load bearing equipment (LBE) and clean uniforms are desirable. However, BF casualties do not need to be in uniform while sleeping, provided adequate sleeping gear (bedding) is available.

- A problem may arise because medical treatment companies, unlike hospitals, do not stock either patient pajamas (which BF casualties should not be given on principle), spare uniforms, or a large supply of sleeping bags. Nor do they have an organic laundry.

- Those personnel who are supervising BF casualties must work with the medical company's supply element to priority requisition necessary clothing, bedding, and equipment items through the supporting logistic element (the FSB, MSB, or area support battalion's S4). It may be necessary to improvise until required items are available. In the corps, the AG replacement company will issue RTD soldiers new clothing, as required,

- A field-improvised laundry (hot water pots and soap) plus patching and sewing repairs may also be a useful "work project" for the recovering BF casualty.

(5) Restorative sleep should be as normal as possible. Most BF casualties will fall asleep quickly with only strong positive reassurance that they will be safe, provided they have relative comfort compared to what they have been used to. It is important to minimize interruptions to sleep. As much as possible, ensure relative quietness (facilitated by dispos-

able earplugs) and darkness (perhaps facilitated by a cravat blindfold).

(a) Bedding may be on a cot, a ground pad, an air mattress, or field expedient hay, pine needles, or leaves. The quality of sleep is important, especially for the first night or two, so the shelter should be as comfortable as is practical and neither too cold nor too hot.

(b) The soldier should be told bad dreams will probably occur soon after he falls asleep and be reassured that they are normal and that he should go back to sleep if awakened.

(c) Muscle stretching routines, massage, and other simple relaxation techniques may help the tense or anxious soldier get to sleep. If available, audiotapes of relaxing background sounds can be played.

(d) Medication for sleep should not be used if food, a hot shower, or relaxation will do. However, BF casualties who are too tense, depressed, or frightened to sleep can be given just enough sleep medication to help them doze off. Possible sleep aids are—

- Diphenhydramine, a sedative antihistamine in most medication sets).

- Low-dose diazepam. A dosage of 2.5 or 5 mg may be administered. The trouble with diazepam is that it and its active metabolites are slowly cleared from the body. Their continued presence in the body and brain may interfere with motor coordination and task performance the next day. The persistence of some pharmacologic antianxiety effect may seem like an advantage, but it actually interferes with the treatment, which is based on helping the soldier master his own anxiety himself.

- Temazepam, if available. This has a biological half-life under 8

hours and should have no residual sedation, antianxiety, or motor skill deficit the next day.

- Triazolam (Halcion).

This sleep aid is even more rapidly cleared but has been reported to produce some memory problems, especially if sleep is interrupted. The person may appear to be normal, but does not remember his experiences later. Some people have difficulty in learning new information the following day.

(e) Antianxiety drugs should not be given routinely during restoration. In most cases, soldiers should not be medicated even with their anxiety. Unmedicated soldiers will be better able to participate actively in their own recovery and perform with appropriate capability if the facility comes under attack or must move.

(f) The duration of sleep should be sufficient to make substantial progress in repaying the sleep debt. It should also begin the process of restoring a reasonable sleep/wake cycle. The start time and wake-up time should be flexible but tend towards sleeping most of the night and being awake all day (or split shift, with sleep in the graveyard shift plus an afternoon nap). Initial sleep should be 8 to 12 plus hours.

e. *Support the Soldier's Military Identity.* Sustain the soldier's identity as a soldier.

(1) Maintain appropriate rank distinctions, titles, and military courtesies from the outset.

(2) Expect the soldier to maintain military bearing, personal appearance, uniform (to include LBE [with canteen, rolled poncho, and first-aid dressing pack as a minimum]), protective mask, and helmet when outdoors unless under special circumstances.

(3) Conduct basic soldiering skills. See FM 8-10 and Appendix D for the limitation of the Geneva Sick and Wounded Convention regarding who may teach what to whom.

f. *Structure Activities During Unit Formations.* Provide structure to the day's activities through regular group formations.

(1) Regularly scheduled formations provide occasions to announce the day's schedule of activities, assign tasks/details to each squad leader, introduce new members, and allow participation by BF casualties in planning how to carry out the assigned activities.

(2) The leaders keep everyone informed by briefings on the "big picture" and tactical situation, with special attention to the activities of the BF casualties' units of origin. Obtain and circulate command information fact sheets and newspapers. Radio and/or television may be available in the theater which are good sources for information.

g. *Assign Duties and Work Details.*

(1) Assign militarily relevant work details at the MTF, preferably to pairs or groups which include BF casualties and non-BF casualties. Examples include—

- Digging foxholes and slit trenches.
- Filling sandbags.
- Erecting and garnishing camouflage when permitted.
- Providing perimeter guard or air watch.
- Performing vehicle preventive maintenance or repair.

- Cleaning equipment.

Work activities must be coordinated with appropriate commanders and subordinates well in advance of casualty flow.

(2) Other obviously relevant and necessary work details include assisting with food preparation and food service at the supporting field kitchen. Battle-fatigue casualties may be used for loading, unloading, and moving supplies. Repairing clothing and equipment, operating the field expedient shower, and improving or making a new latrine are additional appropriate work details. Assisting with the care and movement of other minor wounded and ill may be done and is especially indicated for BF medical personnel. However, these and other duties must not expose the BF soldiers to the critically injured or those awaiting treatment (except for those medics who are in the final stage of recovery just before RTD).

(3) Tasks and work details are assigned according to the status and needs of each case.

(a) Some BF casualties need heavy physical activity to work off energy and complete the unfinished stress-release process. They should be given tools which make this satisfying. Give them shovels and picks that can really move dirt and show accomplishment in minutes, not little entrenching tools that just scratch away at the surface.

#### NOTE

Soldiers who may be violent or unstable should not be given tools which could be used to harm themselves or others.

(b) Other BF casualties who are already physically drained need light duties

that keep them moving and flexible while they recover strength.

(c) Tasks should be chosen to exercise relevant manual and cognitive skills and to ensure a successful and satisfying performance.

(d) Utilize soldiers' skills to teach each other.

*h. Schedule Relaxing Activities.* Provide enjoyable, relaxing activity.

(1) Provide physical training and ensure all are involved in an exercise program.

(2) Organize cooperative/competitive physical team games (involving BF casualties and non-BF casualties). Examples include relay or cross-country races; tug-of-war; touch football, volleyball, or soccer (using a real or improvised ball); softball; or stick ball. These games should be short, vigorous, and balanced with rest and replenishment, as well as the work details.

(3) Organize cooperative/competitive mental games for teams or pairs of soldiers. These include card games or board games like chess and checkers.

(4) Equipment for the physical and mental games can be brought from home upon deployment. Equipment may be mailed by friends and family on request. The equipment may be obtained from the morale/welfare/recreation set or purchased from host nation retailers. Some of the equipment for games may be constructed out of otherwise worthless trash as an individual or team project.

(5) Teach relaxation techniques in group relaxation sessions in which the mental health/CSC person talks everyone through the technique.

i. *Debriefing, Ventilation, and Counseling.* Mental health/CSC personnel (or medics trained by mental health/CSC personnel) provide individual or small group discussion and counseling.

(1) Formal critical event debriefing or ventilation is not usually done in large formations or group activities during brief restoration. The turnover is too rapid to form highly supportive relationships and a clear therapeutic mind-set. Instead, the tendency is for the high percentage of new BF casualties (all of whom have had different bad experiences and who are strangers to the group and to each other) to amplify rather than resolve the distress. When the group begins to move in this direction, the leader reassures the distressed soldiers that he will talk with them later and redirects the group's attention to the next scheduled activity.

(2) After each new arrival has settled in, he is interviewed in detail by the assigned squad leader and/or by the mental health/CSC supervisor or consultant. This interview reviews exactly what happened to bring the soldier here. The focus is on recent events in the soldier's unit or back home rather than on the remote past.

(3) The process is similar to after-action or critical event debriefings. As the details are described, the feelings naturally come out or, at least, show enough signs that they can be reflected and validated as honest and normal. The counselor works patiently to get all the facts and feelings out, then subtly helps to put them into a perspective that reinforces their normality in the combat context. The counselor leads the soldier to seeing how to handle the same or other crisis should a similar situation recur.

(4) The counselor may bring one, two, or more other recovering BF casualties together to talk with the new arrival. This is

based on the counselor's understanding of the soldiers' common experiences and the way they are coping with them. These small, focused groups can often confirm the message of normal, shared experiences better than the counselor can by himself.

(5) As BF casualties recover, the counseling process shifts towards how recovering BF casualties can return to their small units and be accepted there. The counselor must work with the CSC coordinator or other resources (such as the unit chaplains) who can assist this reintegration. Ways to coordinate and facilitate RTD were discussed in Chapter 4.

### 8-3. First-Line Restoration

a. *First-Line Restoration in the Division.* In the division, first-line restoration is usually provided at the FSMC. It is provided by personnel organic to the FSMC, usually assisted and supervised by mental health officers and NCOs from the division mental health section. The combat stress preventive teams from corps-level CSC units may also assist and supervise restoration at the FSMC (See Chapters 2 and 3).

(1) The FSMC is usually located in the BSA which is 25 to 30 kilometers behind the forward line of own troops (FLOT) so that it is just beyond the range of the enemy's main artillery support, however, not beyond range of longer-range tube and rocket artillery, air attack, or forces for special operations.

(2) Depending on the tactical situation, the BSA may have to displace forward or rearward as part of the scheme of maneuver, or have to displace very hastily to escape persistent bombardment or an enemy probe or breakthrough.

(3) For these reasons, restoration in the BSA will often be limited to 2 days or even

1 day, or may have to be temporarily suspended. At other times, when the brigade is being held in reserve, 3 days may be feasible.

(4) In OOTW (conflict), the FSMC may be located at a relatively large and secure fire base or base cluster. Since each scenario is situationally dependent, the command surgeon will establish holding times for first-line restoration.

*b. Separate Brigades or Armored Cavalry Regiments.* In separate brigades or ACR, first-line restoration should usually be provided at the medical company, separate brigade or at the medical troop, ACR. It is provided by personnel organic to the FSMC, perhaps assisted and supervised by a combat stress preventive team from a corps-level CSC unit.

(1) In many scenarios, the separate brigade (or regiment) may be in action similar to that of divisional brigades. Its medical company in the BSA would share the same types of difficulties as the division's FSMCs.

(2) In other scenarios, the brigade/regiment may be in division or corps reserve. It may also be engaged in rear battle against forces which lack the long-range artillery capability of the enemy's main force, but may be more likely to infiltrate and harass. The squadrons of an ACR may also be highly dispersed far from the regimental medical troop. They may be supported by the organic medical platoon. This squadron may depend on corps ASMCs for its Echelon II medical care, including CSC.

*c. Corps and Communications Zone First-Line Restoration.* For CS and CSS units in the corps or COMMZ, first-line restoration should be provided by ASMCs with responsibility for their AO. It is provided by personnel organic to the ASMC, assisted and supervised by NCOs and

perhaps a mental health officer from the ASMB mental health section (see Section II of Chapter 3). If there are large numbers of BF casualties, the ASMCs could also be reinforced by a team from a corps CSC unit.

(1) The ASMC has a holding capacity of 40 cots.

(2) The corps area is likely to be free from artillery attack, except for large, long-range rockets or the smaller rockets or mortars of infiltrating unconventional forces. Air attack is still possible.

(3) Corps ASMCs will be relatively unlikely to have to move on short notice except potentially in rear battle situations. Restoration up to 3 days (and even to 4 days) should usually be feasible.

(4) Those ASMCs in the COMMZ should be even safer and more stable than those in the corps, except in the theater NBC environment. However, they are also vulnerable to rear battle situations.

*d. Medical Company Restoration Support.* Support provided for restoration is a responsibility of the supporting medical companies.

#### NOTE

Combat stress control teams bring specialized skills and perhaps some supplies to help with their critical RTD mission, but do not relieve the local medical commanders of their ultimate responsibility.

(1) When total casualties are light, patient-holding squad elements in division- and

corps-level medical companies provide resources where BF casualties can be rested, fed, and restored. The patient-holding squad personnel (two 91Cs and two 91Bs) serve as treaters. Ideally, the treatment will be under the technical supervision of the mental health section or CSC team personnel.

(2) The holding squad will have two GP medium or large tents with up to 40 cots. When there are few patients, the second tent can be the "rest tent" for HOLD BF casualties and other minor DNBI. The first tent remains ready to receive new arrivals, some of whom may be seriously injured. At some times, of course, the company commander may decide to keep one tent packed on the truck, ready to "jump" if a move is ordered.

(3) Those BF casualties whose symptoms are not dramatic (primarily those showing extreme fatigue, other normal/common "psychosomatic" symptoms, and simple memory loss which could also be due to concussion and therefore require a period of medical observation) can be mixed in with the minimally wounded and minor DNBI cases. Recovering BF casualties whose more dramatic symptoms have improved can also be billeted with true "patients" as long as their imminent RTD is emphasized. Selectivity may be required to ensure they do not "catch" the symptoms of the disease patients, either through true infection or unconscious imitation.

(4) Those cases who are showing more dramatic symptoms of anxiety, depression, physical disability, memory loss, or gross disorganization can be quartered temporarily in a separate tent or expedient shelter. These patients are under the observation of trained medical or CSC personnel. If sufficient shelter is not available for these BF casualties, evacuation to a second-line restoration facility is required. If transported by nonmedical vehicle, an attendant must accompany these BF casualties.

(5) The medical unit's holding resources are available only when WIA and DNBI rates are low. Battle-fatigue rates rise in direct proportion to the intensity of combat (as reflected in the WIA rate). It will be at times of such heavy fighting, when the holding assets are preempted for emergency medical and minor surgical care, that it is most important to restore BF casualties close to their units. At other times, mini-epidemics of gastrointestinal, upper respiratory, or other infectious diseases may fill the holding cots to the exclusion of BF casualties. That BF casualties are moved out into "expedient shelters" to make way for true patients is, of course, consistent with the message of treatment that they themselves are "not sick." However, if weather is inclement and no "expedient shelter" is available, these soldiers are evacuated to a second-line restoration center unless assets are hastily sent forward and set up for them.

(6) Obviously the medical company's patient-holding resources cannot be relied upon for consistent first- or second-line CSC support at times of mass casualties. The organic mental health sections in the divisions or in the ASMB in the corps are without BF casualty-holding capability of their own. If restoration is still to continue to return the BF casualties to duty quickly, reinforcing CSC teams must bring sufficient assets. This includes lightweight/low-cube tentage, working tools, and means to heat water to be able to provide the very basic shelter, food, and hygiene which are the minimum essentials for treatment.

#### 8-4. Second-Line Restoration (Fatigue Center)

*a . Location of Second-Line Restoration.* Each of the forward locations listed above should be backed up by a second-line restoration capability at a location which is relatively less likely

to have to move on short notice. It should have sufficient NP/mental health staff expertise to manage the more problematic cases. These may include clinical psychology, psychiatric nursing, and OT, in addition to social work and psychiatry. The facility should be able to hold these cases for 3 days and conduct a stable, well-organized "fatigue center." Fatigue centers may be located at the MSMC in the division or at the HSC of an ASMB (in the corps or COMMZ).

*b. Fatigue Center.* The name "fatigue center" is suggested for this facility for two reasons. First, it is a central place where fatigued soldiers are sent to rest and recover their strength. Second, it does not sound too attractive—not as attractive and desirable as a rest center. While there, the soldier will be assigned to work details which can be tiring and not especially fun.

*c. Cases Received at the Fatigue Center.* The fatigue center receives all REFER BF cases who must be evacuated from the first-line medical companies. Many of these cases may be sent back for purely tactical reasons, but others are evacuated because their symptoms are too dramatic or unstable to manage so close to the battle. Other soldiers requiring restoration may come from nearby units in rear battle.

#### NOTE

Transportation of BF casualties from BSA to DSA or from ASMC to the ASMB's HSC will be an exception to the usual flow of WIA from the site of initial stabilization directly to hospitals in the corps. For this reason, transportation of BF casualties requires special attention and should be in nonambulance vehicles, if possible.

*d. Restoration Techniques.* The techniques of restoration at the fatigue center are essentially the same as at the more forward locations. The number of cases at any one time is likely to be larger since they may be coming from several forward MTFs and staying longer (up to 3 days). Dealing with the more symptomatic soldiers will also require more interview and treatment skills.

*e. Neuropsychiatric Disorders.* Some of the soldiers sent back from the first-line medical companies will prove to have true NP disorders which require further evacuation to a corps hospital. The second-line fatigue center, therefore, needs to have a neuropsychiatrically trained physician or psychiatric clinical nurse specialist to provide stabilization capability.

*f. Reinforcement by Combat Stress Control Teams.* Combat stress control teams which reinforce to setup a "fatigue center" should bring sufficient tents and equipment to provide formal "holding" for 20 to 40 BF casualties. This can then provide basic shelter" for up to twice that number in the event of a mass casualty situation.

### 8-5. Third-Line Restoration

*a. Operating a Fatigue Center at an Echelon III or Echelon IV Hospital.* In some scenarios, units with soldiers in need of restoration may be significantly closer to a CSH in the corps and a FH or a GH in the COMMZ than to any of the ASMB's medical companies. In such cases, the principles of immediacy and proximity justify conducting a restoration program (fatigue center) at the hospital.

(1) Staffing would be as an additional duty to the NP ward, the consultation service, and the MCWs. These personnel could



be reinforced by teams from the medical company, CSC.

(2) If a task-organized CSC element from the corps medical company, CSC collocated with the CSH (usually to staff a reconditioning program as described in Chapter 9), it could also provide restoration.

*b. Considerations for Restoration at a Hospital.*

(1) The threat to a CSH is similar as to the ASMB. The CSH can move only after much preparation with external assistance.

(2) Restoration at a CSH must be kept clearly separate from the NP ward and ideally from the MCW. It should also be separate from any reconditioning (14 day) program.

**8-6. Return to Duty or Further Referral of Restoration Cases**

Battle-fatigue symptoms do not necessarily improve completely while the prospect of combat continues. The positive expectancy is for RTD of the soldier with sufficient confidence that he can do his job. It does not require that the soldier feels happy, sad, or frighten about his situation. The soldier's condition may continue as post-traumatic stress symptoms, if not necessarily as PTSDs. The symptoms/disorders may occur after the war is over and the soldier has returned home. Most BF casualties in restoration are ready to RTD when they have regained sufficient confidence in themselves and their symptoms have returned to the range of the "normal/common signs." These normal/common signs are outlined in Graphic Training Aid (GTA) 21-3-4. Every reasonable effort should be made to send these soldiers back to their original unit.

*a. Recovered Soldiers in the Brigade Support Area.* Recovered cases from units that

are present in the same BSA are returned directly to their units. For example, a soldier from an infantry company can return through his infantry headquarters and headquarters company, whose field trains are part of the BSA. The medical company patient administration specialist notifies the unit (or equivalent) to send someone to get the soldier.

(1) Consultation by the CSC team with leaders of the BF casualty's parent unit facilitates the recovered soldier's acceptance and transportation back to his unit. Some special cases may require reassignment to another unit which is coordinated through the recovered soldier's battalion S1.

(2) This soldier has been kept on the rolls by his unit during the 1 to 3 days duration of treatment. The summary of treatment for medical statistical purposes is captured by carding for record only, utilizing the FMC. Care provided to this soldier will be considered outpatient treatment and any documentation will be done on the FMC. A copy of the FMC is sent back to the major MEDCOM in the TO upon release of the soldier.

*b. Recovered Soldiers in the Division Rear.* Recovered BF soldiers who have completed restoration treatment in the DSA are returned to duty by contacting the division personnel replacement company. If the soldier's unit is in the DSA, his unit is called. Coordination for return of the soldier to his original unit or for reassignment to a new unit is accomplished through the G1 section. Direct consultation with the forward area unit receiving the recovered BF soldier is coordinated with the forward deployed CSC personnel supporting the unit's AO.

*c. Recovered Soldiers in the Corps.* Return to duty of recovered BF soldiers in the corps depends on where they received their treatment. If an ASMC provided the treatment,

then the ASMC calls the soldier's unit to provide transportation. If the recovered soldier was evacuated to the HSC of the ASMB for restoration, his RTD must be coordinated. The RTD of these soldiers may be complicated because there may not be a routine means of transporting personnel between the remote base defense clusters. Either the soldier's unit must come the distance to collect him or other transportation must be coordinated. Alternatively, he may be returned to his unit by way of the personnel replacement company. Maintaining accountability for such cases is crucial—otherwise, they get lost in the medical evacuation or transportation system and no one knows where they are.

*d. Completing the Recovery.* Some cases in restoration do not improve sufficiently in 3 days to be ready to return to their units and full duty. The cases which are making progress may need additional time to complete the recovery. Some may need only another 1 to 3 days, which need not be spent under full-time medical or mental health/CSC care. Soldiers who require only 1 to 3 days of additional rest for full recovery may be placed in their units' CSS trains as REST BF cases. The CSS trains in the BSA, at a DISCOM unit in the DSA, or in a corps support

command unit in the corps could be used. This must be coordinated with the soldier's unit prior to his disposition.

*e. Referral to Reconditioning.* Those who need further mental health/CSC professional treatment are temporarily reclassified as having "REFER" BF and are sent to the supporting reconditioning program, if one is available. This movement should not be called an evacuation. It should be done without much fanfare (so as not to attract the attention of newly arrived BF casualties). The preferred method of sending the REFER BF casualty is by ground, not air, and in a GP vehicle, not an ambulance. If ambulances must be used, these REFER BF casualties should go as ambulatory (not litter) cases.

*f. Referral to Hospital.* A few cases may be identified by the division or other psychiatrists as having an NP disorder which requires evacuation to a hospital. These may go by ground (or air) ambulance as litter patients.

*g. Referral for Administrative Actions.* A few cases may be identified as malingerers who do not respond to counseling and refuse to RTD. They are turned over to their parent unit for administrative disposition.

## CHAPTER 9

## COMBAT STRESS CONTROL RECONDITIONING

**9-1. Reconditioning Treatment Program**

a. *Overview of Reconditioning.* Reconditioning programs are intensive efforts to return BF casualties to duty when they have not improved sufficiently with 1 to 3 days of restoration. In the corps area these programs are normally 7- to 14-days long but can be as short as 3 days, depending on the corps evacuation policy. Reconditioning may continue as long as 28 days in the COMMZ, depending on the theater evacuation policy. These programs are conducted in a nonpatient care setting by medical CSC, NP, and mental health personnel. Reconditioning also can include rehabilitation of those BF casualties who were evacuated to a hospital without receiving restoration treatment. It can include NP and alcohol/drug patients and minor misconduct stress cases with good potential for RTD. Conducting reconditioning programs is a mission of the medical company, CSC. Reconditioning can also be provided on a small scale by the medical detachment, CSC under special circumstances. Reconditioning is also provided by the combined NP ward and consultation services, the OT/PT sections, and the clinical psychologist of FHs in the COMMZ.

b. *Priority of Reconditioning Programs.* Reconditioning programs have lower priority than restoration programs. This is because they are manpower intensive and have a lower return of RTD for the effort invested. When the number of BF cases who may need 1 to 3 days of restoration treatment is high, additional CSC personnel should be sent forward from reconditioning programs to reinforce forward restoration teams. The reconstitution support mission may also need to draw upon reconditioning program staff.

(1) If a shortage of reconditioning staff is only temporary, it may not be necessary to evacuate the excess caseload. They may be

maintained on a less-intensive program. This program would entail more work details and less individual and group therapy until staffing ratio can be restored.

(2) At times when reconditioning cases far exceed the staff available to treat them, reconditioning may be limited to fewer days per soldier or may be discontinued altogether. This change will effect some of those soldiers in the reconditioning program who might be returned to duty with additional treatment (and might be protected from subsequent PTSD). They will be evacuated to the COMMZ and/or CONUS to maximize RTD of those soldiers with the best potential.

(3) Reconditioning, like restoration, can be provided by successive echelons. Treatment facilities in the COMMZ or corps rear should continue to treat the evacuees with relentless positive expectation. This is called second-line reconditioning. The program should continue as third-line reconditioning for those evacuated to CONUS.

**9-2. Reconditioning Program Methods**

a. *Reconditioning Extends Restoration.* Reconditioning is similar to restoration but more orchestrated over longer periods of time, is more intensive, and it requires a higher staff-to-case ratio. Reconditioning puts special emphasis on a highly structured military unit environment and schedule of activities. Treatment strategies assist recovering soldiers in regaining skills needed for combat duty. These skills and abilities include concentration, team work, work tolerance, psychological endurance, and physical fitness.

b. *Military Unit Structure.* As in restoration, the soldiers are not treated like patients

on a ward under the care of therapists. Rather, the BF casualties are treated like other soldiers assigned to a military unit which requires—

- Assignment to a squad or team with a staff member as squad or team leader.
- Wearing the prescribed uniform and appropriate LBE.

c. *Physical Replenishment.* Reconditioning continues to provide physical replenishment (food, hydration, sleep) and hygiene (shower), especially in the first few days. Later in the program, the comfort factor may be intentionally decreased; for example, by substituting MREs for some A-ration meals and by assigning recovering soldiers to night duties. These duties may include fire watch, perimeter or gate guards, or radio watch.

d. *Unit Formations.* Unit formations are held on a regularly scheduled basis. The purpose of the formation is to—

- Disseminate information.
- Account for all personnel.
- Announce the daily work and training plan or changes.
- Break out or cross-attach sub-elements into small groups for activities or details.
- Introduce new unit members.
- Brief on the tactical and world situation, especially as it relates to the soldiers' units of origin.
- Assign physical and occupational activities.

## NOTE

Display of unit emblems, mottoes, streamers, and other distinctive devices should be encouraged to focus the soldier's attention on his unit of origin and his identification with it.

e. *Physical Reconditioning Activities.* Physical reconditioning activities may include—

- Calisthenics and stretching exercises.
- Running in formation.
- Competitive sports.

f. *Individual Counseling and Therapy.* Individual counseling and therapy may include—

- Abreaction (redescribing and remembering the traumatic events in detail and releasing pent-up emotions).
- Working through personal grief, guilt, and home-front issues.
- For some cases, psychotherapeutic drugs for brief symptom relief, or tapering off drugs used in stabilization or detoxification.
- For some cases, hypnosis or amytol interviews to uncover repressed memories.

g. *Group Sharing and Validation.* Group sharing and validation of common experiences and issues include—

- Restoration of perspective through realistic reappraisal of the traumatic events.
- Cognitive reframing.

*h. Group Training in Relaxation Techniques.* Group training in relaxation techniques is provided and includes—

- Abdominal breathing.
- Breathing for meditation.
- Progressive muscle relaxation/autogenic training.
- Focused imagining of relaxing situations.

*i. Group Training in Life Skills.* Group training in life skills is provided to assist with—

- Control of impulses and anger.
- Appropriate assertiveness in the military context.

*j. Common Soldier Task and Survival Skill Drills.* Common soldier task and survival skill drills may be provided as individual and as team competition.

*k. Drug and Alcohol Abuse Counseling.* Drug and alcohol abuse counseling may be provided through individual or group work sessions as indicated.

*l. Reconditioning Program Work Projects.* Reconditioning program work projects may include—

- Improving and reinforcing defensive positions such as entrenching and sandbagging.
- Improving living conditions such as making furniture or installing packing crate floors.

- Building better showers or latrines.

*m. Work Assignments.* Work assignments to medical units for real work details are—

- Coordinated and monitored by the reconditioning program OT staff.
- Increased over the course of the program and gradually displace most of the therapy and training sessions.
- Considered protected status since they are patients.

*n. Temporary Reassignment to Combat Support or Combat Service Support Units.* When recovering soldiers are temporarily assigned as part of their reconditioning program to CS or CSS units for work, the—

- Assignment of the soldier is for 24 hours of each day.
- Soldiers are no longer in a protected status under the Geneva protocol.
- Combat stress personnel continue to work with the soldier in preparing him for RTD to his original unit, or reassignment to a new unit.

### 9-3. First-Line Reconditioning Centers

*a. Combat Fitness Reconditioning Centers.* Combat fitness reconditioning centers in the corps are staffed by task-organized CSC elements from the medical company, CSC. In OOTW, a reconditioning center could be established by a task-organized CSC element from one or more detachments, CSC. This is done only if the medical company, CSC has not been deployed. Also, if the inpatient NP work load is

light, a small reconditioning program may be staffed by personnel from the NP ward and consultation service of a CSH. A reconditioning center usually collocates with a CSH but must maintain its separate, nonhospital identity.

*b. Area for Establishment.* While the hospital is often in the open, the combat fitness reconditioning centers should be in or close to the tree line or under camouflage. It should not be situated near the morgue, triage area, or helicopter pad. It should be placed in an area where incoming ambulances are not seen as they off load their patients. Often the best area for establishing the combat fitness reconditioning centers is next to the CSH staffs' quarters tents (not among the wards). This is normally close to the food service kitchen, the showers, and the laundry. There the BF casualties receive replenishment and perform work details. The CSC unit (CSC restoration and CSC preventive teams combine as a task-organized CSC element) can provide their own tents for staff quarters and the operations center. They can accommodate a moderate number of soldiers in their own tents for reconditioning (20 per GP large tent in the task-organized CSC element). If the reconditioning case census exceeds the capability of the task-organized CSC element to provide tentage, the additional tents are requested from the medical company, CSC headquarters. If tents cannot be provided, additional shelters and sleeping facilities are requested from the host CSH. In some situations, local buildings may be used or other arrangement made through host-nation agreements. The combat fitness reconditioning centers may be augmented by an element from the medical company, holding. The patient care providers of the holding facility can also be trained (under the supervision of mental health/CSC personnel) to serve as squad leaders, each supervising six to ten BF soldiers.

*c. Working with the Supporting Hospital.* The combat fitness reconditioning center

is dependent on the supporting hospital for communications, food services, shower facilities, and other areas of support. The combat fitness reconditioning center works with the supporting hospital by sending work parties of recovering soldiers to assist in food preparation and delivery and cleanup chores. The recovering soldiers from the reconditioning center may also be used for assisting with work details throughout the hospital but must be under direct supervision of either hospital or mental health/CSC personnel.

*d. Medical Records.* The combat fitness reconditioning center uses the supporting hospital's medical records section to maintain the permanent case records.

(1) Cases who were initially admitted to a hospital ward for stabilization are transferred to the combat fitness reconditioning centers, and the combat fitness reconditioning centers staff continues to keep the standard hospital chart. The soldier is given any personal effects that were secured by the patient administration section at the time of his initial admission.

(2) Cases who are "transferred" from a restoration facility go directly to the combat fitness reconditioning center. They should not be admitted through the supporting hospital's admission area. However, all patient admission steps except securing personal items and affixing a hospital identification wrist band are done upon their arrival at the combat fitness reconditioning center. These steps are accomplished or monitored by the patient administration specialist assigned to the medical company, CSC. The combat fitness reconditioning center also initiates a hospital chart on each case.

(a) Cases in the combat fitness reconditioning center are counted as patients in the reconditioning center on the daily hospital census.

## NOTE

These cases are counted as patients on the daily hospital census. The cases are not counted as occupied beds when reporting the hospital bed occupancy.

(b) Upon disposition from the combat fitness reconditioning center, whether for RTD, retraining for other duty, or evacuation, the combat fitness reconditioning center's psychiatrist prepares the chart for further evacuation or writes the discharge summary and closes the hospital's chart.

e. *Stabilization.* Stabilization of seriously disturbed NP or BF casualty cases should be the responsibility of the collocated hospital's organic NP personnel and NP care ward. Neuro-psychiatric ward cases should not disrupt or infect the combat fitness reconditioning center's nonpatient status, RTD-oriented activities, and atmosphere. Cases can be transferred easily between the hospital's inpatient NP ward and the tents of the combat fitness reconditioning center.

f. *Multiple Small Reconditioning Centers.* The preferred option in a corps-sized operation is to have a separate, small reconditioning center collocated with a hospital behind each division. That combat fitness reconditioning center treats soldiers from that division plus supporting corps units located in its AO. This maintains the principle of proximity and favors immediacy and simplicity by avoiding prolonged transportation of cases. The maintenance of unit identification (most soldiers wearing the same division patch) also aids the positive expectation. Limited resources or geography, however, may require use of consolidated reconditioning centers, which would each support several divisions.

g. *Mature Theater.* In a mature theater, once action in the corps has stabilized,

coordination should be conducted to move the combat fitness reconditioning centers to collocate with (and receive logistical support from) a quartermaster or personnel unit. Hospital charts/medical records would continue to be kept by the nearby CSH.

h. *Division Fatigue Center.* Under special circumstances in OOTW, a division "fatigue center" with few cases in need of restoration could change mission to become a small reconditioning center. Under these special circumstances the medical detachment, CSC personnel could staff a very small reconditioning program. Any patient admitted to this program would be carried as an admission to the supporting CSH. Inpatient records are initiated and maintained by CSC personnel. Upon completion of the reconditioning program, the inpatient record is forwarded to the supporting CSH.

## 9-4. Disposition of First-Line Reconditioning Cases

a. *Status of Reconditioning Cases.* Some reconditioning cases will be able to return to far-forward CS or CSS duty. However, many of the soldiers who need reconditioning will be unable to return to their original unit. This could be a result of combat operations or the nature of their symptoms which prevent their return to original units.

(1) Ideally, BF casualties who undergo a 14-day restoration program in the corps should not be crossed off the division's personnel rolls (as specified in AR 40-216). However, in high casualty situations, the division commander will be unwilling to wait two weeks on the uncertain chance that he will get his old BF soldier (now improved) back again. The commander will want to count soldiers as losses to the division if they are gone more than 3 days in order to requisition replacements. Even when BF casualties

are no longer on the division's rolls, every feasible effort should be made to return those BF cases who recover fully to their original units. This is desirable even if that unit has already received a replacement and is technically not eligible to receive another. Most units in combat are chronically understrength and they can also anticipate more losses in the near future. An overly strict interpretation of the replacement policy should not prevent the mutually beneficial return of a recovered soldier to his unit. The division psychiatrist and the CSC unit teams who are attached to reinforce that division should maintain frequent contact with the combat fitness reconditioning centers which supports the division (as specifically directed in AR 40-216). Coordination efforts, through the DMOC and the personnel replacement system by division mental health/CSC personnel, should attempt to facilitate return of recovered soldiers to their original units.

**NOTE**

The CSC consultant should also ensure that everyone knows that it is just as important (if not more so) to return recovered WIA and DNBI soldiers to their original units whenever possible.

(2) More commonly, reconditioned soldiers may need reassignment (and perhaps reclassification into new MOSS) and/or on-the-job training into new combat, CS, or CSS roles. If recovered BF casualties cannot be returned to their previous small unit, they should be formed into small (two to five persons) cohesive groups or teams which can be reassigned to a new unit together (or to the unit of one of those soldiers). The combat fitness reconditioning centers must coordinate with the personnel replacement system and nearby CSS units to find a suitable

assignment for these newly formed two- to five-person teams.

(3) For some cases, it may be best to have the recovering BF casualty (as part of their reconditioning program) visit with nearby units during the day (returning to the combat fitness reconditioning center at night) before being returned to duty for assignment. Any work performed during such visits must conform to the Geneva Conventions (see Appendix D). Alternatively, the recovering BF casualty may be assigned to the CSS unit 24 hours/day on temporary duty as a REST BF casualty until he is ready for reassignment (preferably in pairs or groups) to other units.

*b. Evacuation Policy.*

(1) Army Regulation 40-216 specifies that there should be a 14-day reconditioning program in the corps. This recognizes the fact that the additional days substantially increase the RTD rate. At the NP clearing companies in WWII, the average length of stay was 11.4 days. The corps evacuation policy is at the discretion of the theater commander. In some situations, the maximum length of stay may be set by the theater commander at 7 days.

(2) If the corps evacuation policy is less than 14 days, the mental health/CSC staff psychiatrist of the medical brigade should request an exception for BF casualties in reconditioning programs. He submits the case via the commander, medical brigade, through the corps surgeon to the corps commander. The following facts apply:

(a) The reconditioning program, because of its austerity, is not a significant logistical burden to the corps—it requires only food, water, and shelter for the cases, plus the supplies and equipment from quartermaster units



that rearm the recovered soldier for combat or other duties.

(b) Because the combat fitness reconditioning center maintains a military setting, it is not a conspicuous target. Its case-load performs useful work details and perimeter defense, either for medical units or for all type units, depending on its chosen Geneva Conventions status (see Appendix D).

(c) The increase in RTD of BF casualties (mostly to CSS units) frees assigned soldiers for other duties, reduces the accumulation of cases with poorer prognoses in the COMMZ, and minimizes chronic disability.

c. *Evacuation.* Reconditioning cases who do not recover sufficiently to return to some duty within the designated evacuation period are evacuated from corps to COMMZ. They are best transported in GP trucks and buses, bus ambulances, or an ambulance train. In the latter two cases, they should be assigned helper tasks. Use air evacuation if there is no other alternative.

## 9-5. Second-Line Reconditioning in the Communications Zone

a. *Option 1—Field Hospital.* Establish reconditioning programs in the COMMZ at one or more FH. The FH is preferred to the GH because it is dedicated to RTD of convalescing cases. It has a psychologist and OT personnel assigned to the hospital unit's medical holding. These personnel are in addition to the NP ward and consultation service personnel assigned to the hospital unit base.

(1) The FH has sufficient mental health staff to conduct a small reconditioning program, provided it is not preoccupied with NP cases. However, most of its recondition-

ing capability will be required for the estimated 10 percent of the RTD wounded who also have significant BF. This capability could be improved somewhat by attaching a platoon of the medical company, holding.

(2) It is still important to minimize the hospital atmosphere and to treat the cases not as patients but as soldiers being reconditioned for combat-related duties. (The same is true for the convalescing WIA with concurrent BF.) The facility should be in a separate building with its own rigorous schedule of therapeutic activities, physical training, and work projects.

b. *Option 2—Combat Stress Control Units.* A medical company, CSC may be allocated to the COMMZ and assigned to the medical brigade. The medical company, CSC, reinforced with a patient-holding capability, may establish separate "nonhospital" reconditioning centers in the COMMZ.

(1) In OOTW, task-organized CSC elements of a medical company or a medical detachment, CSC combine with a 240-cot platoon of the medical company, holding. Attach this combat fitness reconditioning center to a FH or GH.

(2) Limited conflict is defined here as either—

(a) A relatively small conflict which does not require all CSC units in the forward areas of the corps.

(b) The late stages of a larger war when fighting has stabilized or ceased, so that CSC units can be withdrawn from forward areas to provide reconditioning in the COMMZ. In the latter (late in the war) situation, some of the work load may include cases who have accumulated in the COMMZ. These cases may

not have received mental health/CSC treatment because there were insufficient evacuation assets to transport them to CONUS along with the wounded and the true NP cases. These would make a difficult, but still potentially rewarding caseload.

*c. Second-Line Reconditioning Cases.* Most second-line reconditioning cases will no longer need much physical replenishment. The combat fitness reconditioning center programs continue to emphasize physical fitness, soldier skills, work details, and individual/group counseling/psychotherapy. Cases will be retrained for CSS duties in COMMZ and corps. As soon as the recovering soldiers are ready, the retraining site can shift to on-the-job training at a nearby CSS unit. This training begins as a day job, returning each night to the combat fitness reconditioning center. Later, the soldier may be placed full time in the new unit (as DUTY BF) while being followed-up periodically by the combat fitness reconditioning center's staff.

## 9-6. Third-Line Reconditioning

*a. Battle Fatigue Casualties That Fail to Improve.* Those BF casualties who do not improve sufficiently to RTD in the COMMZ are sent to CONUS. If these BF casualties have not been found to have some NP or physical disorder, they should be transferred to a third-line reconditioning center in CONUS. If they have NP or physical disorders which warrant discharge from the Army, they are sent to the Department of Veterans Affairs for additional treatment and follow up. The facilities for the reconditioning centers should be located at MEDDACs or medical centers which are on active Army posts that provide the military atmosphere and the opportunity for job retraining in actual units.

*b. Sending to Appropriate Reconditioning Center.* The BF casualty should be sent to the reconditioning center which is best suited for the retraining to be done. This center is often not the one that is nearest the soldier's home of record.

## APPENDIX A

**LISTING OF MAJOR ITEMS OF EQUIPMENT FOR  
THEATER ARMY MEDICAL COMBAT STRESS CONTROL  
UNITS AND ELEMENTS**

**A-1. General**

The major items of equipment in this listing are authorized by the base TOE and other required items are authorized by the common table of allowances (CTA).

**A-2. Medical Company, Combat Stress Control***a. Headquarters Section.*

include— (1) Major items authorized by the base TOE and assigned to the headquarters section

Truck, cargo, tactical, 2 1/2-ton (two each); one truck has a winch.  
Trailer, cargo, 1 1/2-ton (one each).  
Truck, utility, 1/4-ton (one each).  
Trailer, cargo, 1/4-ton (one each).  
Tow bar, motor vehicle (one each).  
Generator, 5 kilowatt (one each).  
Radio set, AN/VRC 90 (one each).  
Radio set, control group, AN/GRA-39 (one each).  
Tool kit, general mechanic, automotive (three each).  
Tool kit, carpenters (one each).  
Tool kit, small arms repairman (one each).  
Camouflage screen support system (nine each).

(2) Major items of CTA equipment assigned to the headquarters section include—

Tent, general purpose, large (one each).  
Tent, general purpose, medium (two each).  
Tent, general purpose, small (three each).  
Tent, vehicle maintenance (one each).  
Tent liner, general purpose, large (one each).  
Tent liner, general purpose, medium (two each).  
Tent, general purpose, small (three each),  
Panel marker set, Geneva (three each).

b. *Preventive Section.*

include— (1) Major items authorized by the base TOE and assigned to the preventive section

Truck, cargo, tactical, 5/4-ton (six each) with 3/4-ton trailers, cargo (six each).  
Medical equipment set, sick call, field (six each).  
Clinical psychologist set, field (one each).  
Generator, 5 kilowatt (one each).  
Camouflage screen systems for woodland and desert.

(2) Major items of CTA equipment assigned to the preventive section include—

Tent, general purpose, medium (six each).  
Tent liner, general purpose, medium (six each).  
Panel marker, Geneva (six each).

c. *Restoration Section.*

include— (1) Major items authorized by the base TOE and assigned to the restoration section

Truck, cargo, tactical, 5/4-ton (four each) with four trailers, cargo.  
Truck, cargo, 2 1/2-ton (four each) with trailers, 1 1/2-ton (four each).  
Trailer, tank, 1 1/2-ton, water, 400 gallons (two each).  
Generator, 3 kilowatt (four each).  
Medical equipment set, sick call, field (four each).  
Clinical psychologist set, field (four each).  
Tool kit, carpenters (four each).  
Camouflage screen systems, woodland and desert.

(2) Major items of CTA equipment assigned restoration section include—

Tent, general purpose, large (ten each).  
Tent, general purpose, medium (four each).  
Tent, general purpose, small (four each).  
Tent liner, general purpose, large (ten each).  
Tent liner, general purpose, medium (four each).  
Tent liner, general purpose, small (four each).  
Panel marker, Geneva (four each).

### A-3. Medical Detachment, Combat Stress Control

#### a. Detachment Headquarters.

include— (1) Major items authorized by the base TOE and assigned to the restoration section

Truck, cargo, tactical, 5/4-ton with trailers, cargo, 3/4-ton.  
 Generator, 3 kilowatt (one each).  
 Radio set, AN/VRC 90.  
 Telephone set, TA312 (one each).  
 Camouflage screen systems, woodland and desert.

(2) Major items of CTA equipment assigned to the headquarters section include—

Tent, general purpose, small (one each).  
 Tent liner, general purpose, small (one each).

#### b. Preventive Section.

include— (1) Major items authorized by the base TOE and assigned to the preventive section

Truck, cargo, tactical, 5/4-ton (three each) with 3/4-ton trailer, cargo (three each).  
 Medical equipment set, sick call, field (three each).  
 Clinical psychologist set (three each).  
 Telephone set, TA 312 (three each).  
 Tool kit, carpenter (three each).  
 Camouflage screen systems, woodland and desert.

(2) Major items of CTA equipment assigned to the preventive section include—

Tent, general purpose, medium (three each).  
 Tent liner, general purpose, medium (three each).

#### c. Restoration Team.

include— (1) Major items authorized by the base TOE and assigned to the restoration section

Truck, cargo, tactical, 5/4-ton (two each) with trailers 3/4-ton, cargo (two each).  
 Truck, cargo, 2 1/2-ton with trailer, 1 1/2-ton (one each).  
 Trailer, tank, 1 1/2-ton, water, 400 gallons (one each).  
 Medical equipment set, sick call, field (one each).  
 Tool kit, carpenters (two each).

Camouflage screen systems, woodland and desert.  
Clinical psychologist set (one each).  
Telephone set, TA 312 (one each).

(2) Major items of CTA equipment assigned to the restoration section include—

Tent, general purpose, large (two each).  
Tent, general purpose, medium (one each).  
Tent, general purpose, small (one each).  
Tent liner, general purpose, large (two each).  
Tent liner, general purpose, medium (one each).  
Tent liner, general purpose, small (one each).  
Panel marker set, Geneva (two each).

#### A-4. Division Mental Health Section

a. Major items authorized by the base TOE and assigned to the mental health section include—

Truck, utility, 5/4-ton (three each).  
Clinical psychologist set (one each).  
Camouflage screen support system (thirteen each).  
Telephone set, TA-312/PT (one each).

b. Major items of CTA equipment assigned to the division mental health section include—

Tent, general purpose, medium (one each).  
Tent liner, general purpose, medium (one each).  
Panel marker set, Geneva (one each).

#### A-5. Area Support Medical Battalion Mental Health Section

a. Major items authorized by the base TOE and assigned to the mental health section include—

Truck, cargo, tactical, 2 1/2-ton (one each),  
Truck, utility, 3/4-ton (three each).  
Camouflage screen support system (thirteen each).  
Telephone set, TA-312/PT (one each).

b. Major items of CTA equipment assigned to the headquarters section include—

Tent, general purpose, medium (one each).  
Tent liner, general purpose medium (one each).  
Panel marker set, Geneva (one each).

## APPENDIX B

## COMBAT STRESS CONTROL ESTIMATES AND PLAN

## Section I. GUIDE FOR THE DEVELOPMENT OF THE COMBAT STRESS CONTROL ESTIMATE OF THE SITUATION

**B-1. Combat Stress Control Estimate**

The CSC planner must prepare the CSC estimate in cooperation with the senior staff surgeon who is responsible for preparing the overall CHS estimate. The overall CHS estimate, and especially the PVNTMED estimate, provide important information (see FMs 8-55 and 8-42).

a. Some issues may require the CSC planner to work directly with the staff sections of the combat command: S1/G1, S2/G2, S3/G3, S4/G4, and, G5 when appropriate. The staff chaplains (unit ministry teams), JAG, and Provost Marshal and MP units are also important sources of information.

b. The level of detail of the CSC estimate depends upon which echelon is preparing it.

(1) The division mental health section works with the division surgeon and the PVNTMED section. The division mental health section is concerned with brigades which are likely to have the most BF cases or other combat stress and NP problems. This may determine how many assets are pre-positioned and at which BSAs. Within the brigades (and in the DISCOM), the division mental health section may need to identify specific battalions, companies, and platoons in order to focus preventive consultation or reconstitution support activities.

(2) The CSC units which provide backup support and reconditioning in the corps are concerned with divisions, separate brigades/regiments, and other corps units which are likely

to generate the most stress casualties. The medical detachment or CSC company—

- Receives the CSC estimates from the division mental health section or ASMB mental health section and coordinates directly with each.

- Develops its CSC estimate in conjunction with its higher medical C2 unit.

- Prepares to receive reconditioning cases at different regions of the battlefield.

- Sends CSC augmentation teams or personnel to reinforce the forward units that have the greatest need.

**NOTE**

The medical group and medical brigade headquarters will have a small mental health staff section to help coordinate these activities.

c. The primary objective of the CSC estimate is—

- To predict where and when the greatest need is likely to arise among the supported units.

- To initiate preventive efforts early.

- To develop contingency plans so that limited resources can be allocated and prepared for their reallocation as needed.

(1) Quantification of the projected restoration and reconditioning caseloads will not be precise. Absolute values should not be given too much weight. However, quantification provides a useful analytical tool for estimating relative risk. The historical ratios of the incidence of BF casualties to the incidence of WIAs provide a baseline for estimates in future operations.

(2) This analysis is most valid when applied to specific units in a specific combat operation. It is less precise when applied to larger, composite units. The analyst must estimate what percentage of subunits of different types (combat, CS, and CSS) will encounter particularly negative factors (stressors). He must also estimate what percentage will be protected by beneficial protective factors.

(3) The prediction for the incidence of WIA requiring hospitalization in the CHS estimate provides a starting point. In moderate to heavy conventional fighting (mid-intensity conflict), the CSC planner can begin with the average ratio of one BF casualty for five WIA (1:5). Then he can examine the nature of the mission for each of the specific units involved and use protective (Positive) and risk (Negative) factors to judge whether 1:5 is likely to be an overestimate or an underestimate.

(4) For discussion later in this appendix (paragraph B-2), the protective and risk factors for BF are referred to by their parenthetical subparagraph numbers and are identified as either (Positive) or (Negative).

(5) Each of these factors could be given a numerical weight (0, +1, +2 for positive factors; 0, -1, -2 for negative factors). The factor scores are added algebraically to give a rough total score. The weight must be based on subjective expert judgment and experience.

(6) The same analyzing process used to estimate BF casualties in relation to WIAs

can be applied to estimating the potential for substance misuse/abuse patients and other misconduct stress behaviors compared with their normal rates of occurrence in the troop population.

(7) The protective (Positive) and risk (Negative) factors for misconduct stress behaviors in paragraph B-3 will be similarly designated, but with a letter "m" (for "misconduct") after the parenthesis. Each factor will be identified as either Positive or Negative.

## **B-2. Estimating Battle Fatigue Casualty Work Load**

*a. Protective Factors.* The following protective (Positive) factors reduce BF casualties relative to WIA:

(1) High unit cohesion (Positive). Troops and their leaders have trained together (and, ideally, have been in successful combat) with little continual turnover of personnel. For example, Operational Readiness Training companies and battalions are presumed to have high unit cohesion provided the leaders have had time and training to develop "vertical cohesion" with positive factors (5) and (6), below.

(2) History of very tough, realistic training (for example, militarily sound and dangerous preparation to prepare troops for war) (Positive). Successful combat with few casualties is good training. Airborne and Ranger training and realistic live-fire exercises (both small arms and artillery) also help to "battle proof" soldiers.

(3) Unit leaders and medical personnel are trained to recognize BF (Positive). They can manage DUTY and REST cases at unit level and reintegrate recovered HOLD and REFER cases back into units.



(4) Units are withdrawn from combat periodically to rest, refit (reconstitute if necessary), and absorb new replacements (Positive). Replacements arrive and are integrated as cohesive teams, not as individual soldiers.

(5) Leaders demonstrate competence, courage, and commitment (Positive). Leaders care for their soldiers and make provisions for physical and mental well-being as the tactical situation permits. Noncommissioned officers know and are given responsibility for sergeant's business (taking care of their troops). Command also shows concern for soldiers' families.

(6) Leaders keep troops informed of commander's intent and the objectives of the operation and the war (Positive). If necessary, they focus the soldiers' appraisal of the situational stressors to maintain positive coping.

(7) Victorious pursuit of a retreating enemy (Positive). This reduces BF casualties but may release misconduct stress behaviors unless command retains tight control.

(8) Hasty withdrawal (Positive). During hasty withdrawals, few BF casualties enter medical channels. However, BF soldiers may be lost as KIA, missing in action (MIA), or captured instead of becoming medical patients, and other soldiers who are stressed may desert or surrender.

(9) Beleaguered friendly unit which cannot evacuate any (or only the most severely wounded) casualties (Positive). Here, too, some soldiers may be combat ineffective due to BF or go AWOL without becoming medical patients.

*b. Assessment of the Positive Protective Factors.*

(1) Positive factors (1) through (6), above, can be assessed using standard

questionnaire surveys of unit cohesion and morale, such as the Unit Climate Profile found in DA Pam 600-69.

(2) Many leaders and soldiers want to believe that their unit is elite and will have far fewer than one BF casualty for ten WIA, even in the most intensive battles. The CSC planner should not discourage this belief since it may be a necessary first step toward becoming true. However, the CSC estimator should not make plans on the strength of the belief alone. Remember, CSC expertise is managed wisely if it is far forward, assisting command in proactive prevention rather than reactive treatment of BF casualties.

(3) Even if tough realistic training, high cohesion, and fine leadership can be independently verified (as with unit survey questionnaires), the BF casualty estimate should not be too much less than the average until the unit has proved itself in successful combat. Even then, estimates should continue to consider the potential negative impact of cumulative attrition, new replacements, and other adverse factors which may eventually overcome the positive factors.

(4) Positive factors (8) and (9), above, are, of course, not truly "Positive." While they decrease the expected requirement to evacuate BF casualties for treatment, they indicate a need to redouble efforts for prevention of misconduct stress behavior. Positive factor (7), above, also should alert command to the need to maintain firm control to prevent misconduct stress behavior.

*c. Risk Factors.* Increases in the following risk (Negative) factors add to the proportion of BF casualties in relation to WIA:

(1) Combat intensity—indicated by the rate of KIA and WIA (percent of battle casualties [out of the total troops engaged] per hour or day) (Negative).

(2) Duration of continuous operations—the number of days which the troops (small units) have been in action without respite, especially if there is little opportunity for sleep (Negative). The operation may begin well before the actual shooting. Preparation time and rapid deployment (jet lag) effects should also be considered.

(3) Cumulative combat duration—the total number of days (cumulated over days, weeks, months) in which the small units (platoons, companies) have suffered casualties (Negative).

(4) Sudden transition to the horrors of war—many new troops with no prior combat experience being confronted with surprise attack or new weapons of mass destruction (Negative).

(5) Extent to which the troops are subjected to artillery and air attack (with some allowance for the strength of their defensive fortification, dispersion, and concealment) (Negative). This is especially true if they involve sudden mass devastation.

(6) Casualties from friendly fire (including direct fire, artillery, and air attack) (Negative). This, of course, is not part of the plan of operation but is a special hazard of the fast-moving battle. When such incidents are reported, CSC teams should respond immediately.

(7) High NBC threat—a state of alertness requiring periods in MOPP Levels 1 through 4, frequent false alarms, and concerns and rumors about escalation (Negative). Actual NBC use: What type agents? (Persistent contamination? Potential for contagion?) What casualties? What are the implications for increased MOPP levels, rumors, concerns of escalation, and worries about home?

(8) Being on the defensive, especially in static positions (unless the fortifications

are very strong and comfortable, complacency may be a problem) (Negative).

(9) Attacking repeatedly over the same ground against a stubborn, *strong* defense (Negative).

(10) Casualties among armor or mounted infantry crews, such as when armor must operate in highly restrictive terrain (Negative).

(11) Casualties from mines or booby traps (Negative).

(12) Extent and intensity of the rear battle (Negative). The introduction of CS/CSS soldier to the stress of battle when attacked. These soldiers are confronted with dangers and horrors of war for which they may not have been adequately trained or mentally prepared.

(13) Failure of expected support, such as fire support, reinforcement, or relief; inadequate resupply; inadequate CHS support (Negative).

(14) High personnel turbulence, resulting in low unit cohesion and inadequate unit tactical training (Negative).

(15) Loss of confidence in leaders, in supporting or allied units, and in equipment as compared to the enemy's (Negative).

(16) Popular opposition to the war at home; lack of understanding or belief in the justness of the effort (Negative).

(17) Families left unprepared by rapid mobilization and deployment (Negative). Lack of a believable plan for evacuating families from the theater; lack of plans for keeping them secure under a reliable authority if they cannot be evacuated. This can also contribute to misconduct stress behaviors, especially AWOL.

(18) Home front worries (Negative). Lack of visible command program for ensuring support to Army families.

(19) Inadequate water available for drinking (Negative).

(20) Adverse weather, especially cold-wet; any harsh climate if troops are not properly trained, equipped, and acclimatized (Negative).

(21) Unfamiliar, rugged terrain (jungle, desert, mountain, or urban) if troops are not specifically trained and equipped (Negative).

(22) High prevalence of endemic minor illnesses, especially if this reflects inadequate command emphasis on self-aid and buddy aid preventive measures (Negative).

(23) Last operation before units (or many soldiers in them) rotate home, or if the war is perceived as already won, lost, or in final stages of negotiation (Negative).

(24) Many civilian women and children casualties resulted from the fighting (Negative). This may be a stronger factor in brief OOTW (conflict) than in war where the magnitude of the horror and the preoccupation with personal and unit survival may quickly harden soldiers to these casualties.

### **B-3. Estimating Substance Abuse and Misconduct Stress Behaviors**

*a. Protective Factors.* Positive Factors (1) through (6), above, reduce alcohol/drug misuse and other misconduct stress behaviors (Positive). They can also become misconduct behaviors as shown in (b), below.

(1)m High unit cohesion is positive if the unit's "identity" forbids abuse of substances

and emphasizes adherence to the Law of Land Warfare, United States Code of Military Justice, and tolerance for cultural differences (Positive).

(2)m History of tough and realistic training is positive if it includes faithful adherence to rules of engagement which support the Law of Land Warfare and cultural issues (Positive).

(3)m Unit leaders, medical personnel, and chaplains are trained to recognize BF and early warning signs of misconduct stress (Positive).

(4)m Units are withdrawn from combat periodically to rest, refit (reconstitute, if necessary), and absorb new replacements who arrive and are integrated as cohesive teams, not individuals (Positive).

(5)m Leaders have demonstrated competence, courage, candor, and commitment (Positive). Leaders show caring for the soldiers and make provisions for their physical, mental, and spiritual well-being as the tactical situation permits.

(6)m Leaders keep troops informed of the objectives of the operations and war (including psychological operations and diplomatic, political, and moral objectives) (Positive). They focus the soldiers' appraisal of the situation to maintain positive coping against the temptations to misconduct stress behaviors.

#### **NOTE**

These preventive factors will protect only if leaders and troops maintain and enforce a unit's self-image that regards the misconduct behaviors as unacceptable. If this unit's self-image is lacking, these factors may even contribute to substance abuse and violations of the laws of war.

b. *Risk (Negative) Factors Which Increase Substance Misuse and Other Harmful Combat Stress Behaviors.*

(1)m Permissive attitude and availability and use of drugs in the TO and also in the US civilian community, especially around posts/garrison areas and in the regions and age groups from which recruits are drawn (Negative).

(2)m Inadequate enforcement of the unit's ADAPCP before deployment in identifying and treating (or discharging) misusers (Negative).

(3) Availability and distribution networks (both legal and illegal) for alcohol and different types of drugs in the theater (Negative). Some drugs are more available and cheaper in some foreign countries or regions.

(4)m Unsupervised use of amphetamines and other strong stimulants to remain awake in continuous operations (Negative). This can produce dangerous (usually temporary) neuropsychiatric illness. Also, it may lead to dependency and addiction in originally well-intentioned, good soldiers, including leaders.

(5)m Boredom and monotonous duties, especially if combined with chronic frustration and tension (Negative).

(6)m High threat of nerve agent use with false alarms that result in self-administration of atropine causing mental symptoms and perhaps temporary psychosis (Negative).

(7)m Victorious pursuit of a retreating enemy. This reduces BF casualties, but may not inhibit commission of atrocities (the criminal acts of killing of EPWs, raping, looting) or alcohol/drug misuse (as supplies are "liberated") unless command retains tight moral control (Negative),

(8)m Hasty withdrawal. Here, too, soldiers may loot or abuse substances "to keep them from falling into enemy hands" (Negative). Rape, murder, and other reprisal atrocities (criminal acts) can occur if retreating troops feel hindered by EPWs, or if the civilians being left behind are hostile. Leaders must not encourage too zealous a scorched-earth policy. This means that only those items except medical that would be of potential use to the enemy are destroyed. If leaders lose tight control, overstressed soldiers may desert or surrender.

(9)m Beleaguered units which cannot evacuate any (or only the most severely wounded) casualties. Here, too, some soldiers may commit misconduct stress behaviors due to BF or go AWOL without becoming medical patients (Negative).

(10)m Commission of atrocities by the enemy, especially if against US personnel but also if against local civilians (Negative).

(11)m Racial and ethnic tension in the civilian world and in the Army (Negative). Major cultural and physical/racial differences between US and the local population,

(12)m Local civilian population perceived as hostile, untrustworthy, or "sub-human" (Negative). This is more likely to result when soldiers have little knowledge or understanding of cultural differences.

(13)m Failure of expected support, such as reinforcement or relief; inadequate resupply; inadequate CHS (Negative). Soldiers who feel abandoned and on their own may resort to illegal measures to get what they think they need. Combat soldiers naturally tend to feel "entitled to claim what they have earned," and this may lead to looting and worse.

(14)m High personnel turbulence, lack of unit cohesion, especially "vertical cohesion"

between leaders and troops (Negative). A “substance-of-choice” can become a “ticket” for inclusion into a group.

(15)m Loss of confidence in leaders, in supporting or allied units, and in equipment as compared to the enemy’s (Negative). These produce the same effects as negative factors (13)m, above, and (16)m, below.

(16)m Popular opposition to the war at home; lack of understanding or belief in the justness of the effort (Negative). Some soldiers will find this an excuse to desert or refuse lawful orders. Others who continue to do their duty may show their resentment by lashing out at the local population or by using drugs and alcohol.

(17)m Lack of a believable plan for protecting families in the theater, either by evacuating them or keeping them secure under reliable authority (Negative). Some soldiers may go AWOL to stay with them.

c. *Estimate of Substance Abuse and Misconduct Stress Behavior.* The purpose of this estimate of potential substance misuse and other misconduct stress behaviors is the same as for the estimate of BF casualties. It is to predict when and where (in which units) problems are most likely to occur so that preventive actions can be focused. Also, provisions can be made for the medical/psychiatric treatment of substance abuse cases in the TO. The CSC estimator must work closely with the JAG staff, MP, and the chain of command to compare the projections with what is actually being found.

## Section II. THE COMBAT STRESS CONTROL PLAN

### B-4. Format

The format for the CSC plan is the standard outline (see FM 8-55). The CSC planner must analyze the operations order and CHS estimate for direct or implied CSC missions. He must assess the available CSC resources and analyze alternative ways of using them to accomplish the missions. Frequently, it is necessary to prioritize the missions and recommend to higher command which of the alternate courses should be taken.

### B-5. Combat Stress Control Planning Considerations in Deployment and Conflict

a. The requirements for each of the CSC program functions (consultation, reconstitution support, NP triage, restoration, reconditioning, and stabilization) and the ability of CSC units

to satisfy those requirements will be influenced by the factors listed below:

(1) The nature, mobility, and intensity of combat operations which influence the number of BF soldiers; the severity of symptoms; and the feasibility of resting cases in or near their units.

(2) The type of threat force, especially the threat to CSC activities themselves. For example, the likelihood of air and artillery attack; the security of “rear areas” for rest; the electronic warfare threat and target detection capability for concentrations of troops; and the NBC and directed-energy threat.

(3) The availability of other health service units on which the CSC elements can rely for local logistical/administrative support and for patient transportation or evacuation.

(4) The geographical AO, terrain, and climatic conditions which limit mobility of CSC units and require additional shelter for patients.

(5) The disease, drug, alcohol, and environmental hazards of the region which threaten resting BF cases and produce other preventable nonbattle injuries which, historically, resulted from there being a complication of BF.

b. The CSC planner must determine the actual strengths of the CSC resources in organic unit mental health sections and specialized units. They may not be at the authorized levels for personnel or equipment. The level of training, degree of familiarity, and cohesion with the supported units must be assessed.

#### **B-6. Combat Stress Control Planning Considerations for War**

a. The more intense the combat, the higher the rate of WIA and the higher the ratio of BF casualties to WIAs. If the WIA rate doubles there will be four times as many BF cases requiring treatment. Furthermore, high-intensity combat causes a shift towards more severe symptoms and slower recovery.

b. The CSC organization must achieve a balance between pre-positioning elements far forward and having other elements further to the rear that can take the overflow of cases and be redeployed to areas of special need.

c. In Army operations, each maneuver brigade covers a larger and more fluid area and has greater firepower and responsibility than did a WWII division. Winning the first battle will be critical and can be accomplished only by reconstitution of attrited units and rapid return of temporarily disabled soldiers to their units. The

division mental health section must be reinforced if cases are to be restored in the BSA and DSA.

d. Small CSC teams must be pushed forward to reinforce the maneuver BSA well before the fighting starts. Although BF casualties will not be evenly distributed among all brigades, those cases which occur must be evaluated and treated immediately at that level.

(1) At critical times, this will be under mass casualty conditions. Other logistical requirements and enemy activity may make it impossible to respond quickly with CSC personnel once the battle has begun. Any newly arriving CSC personnel who join a new unit under such circumstances will take critical hours to days to become efficient.

(2) The purpose of these CSC "preventive" teams is NOT to hold BF casualties for treatment in the highly fluid BSA. Their purpose is to prevent the evacuation of DUTY and REST BF casualties who could remain with their units. These teams also ensure correct initiation of treatment and evacuation of the refer cases to the division fatigue center in the DSA. If circumstances allow, they could hold a small number for overnight observation/restoration.

(3) Combat stress control teams which are with a brigade not in action will use this time productively in consultation activities. These activities will reduce the incidence of stress casualties and better enable the unit to treat its cases far forward when the time comes.

e. Combat stress control elements in the DSA provide NP triage and prevent any unnecessary evacuation. They staff the division fatigue center which assures 2- to 3-days restoration within the division. They provide preventive consultation and reconstitution support throughout the division rear. They can send personnel, tents, and supplies forward to reinforce the teams at the BSA.

*f.* Combat stress control elements in the corps area must provide the back-up "safety net" to catch the overflow from hard-pressed divisions, as well as providing reconstitution support to units which are withdrawn from battle and preventing and treating local rear-area BF cases. Those in the corps area can be transferred laterally within the corps or temporarily sent forward to divisions which are in greatest need. With somewhat greater difficulty, these assets can be transferred from one corps to another.

*g.* Combat stress control teams need 100 percent ground mobility and communications capability to function in their local areas. They need a small vehicle to visit the units in the BSA, DSA, or corps support area and to deploy to reconstitution sites with other CS/CSS teams. Combat stress control teams should not wonder around the battlefield alone. When they move outside the defensive areas, they should be in convoy with other CSS vehicles or be provided security by the echelon commander.

*h.* Combat stress control units provide the expertise of their personnel with little requirement for heavy equipment. Therefore, if time, distance, or the tactical situation prevents a CSC element from traveling by ground to reinforce another CSC element which is already in place, the key personnel and light specialized equipment can be moved by air.

#### NOTE

Combat stress control personnel can be sent forward in air ambulances that are going to the forward medical companies to evacuate the wounded.

Additional supplies, equipment, and vehicles can follow as sling-loaded or air-droppable cargos. The key requirement is that a familiar CSC team

with vehicle and preestablished contacts are already at the destination expecting to be reinforced.

*i.* If the division mental health section or CSC unit is given the mission to support a separate brigade or ACR, it is important to establish contact and send a liaison officer or NCO to its medical company as early as possible before the battle.

#### NOTE

Because of their unique missions, armored cavalry units have special need for consultation, preventive education, and staff planning.

Because of their elite self-image, it is important that the liaison is someone who has trained with the unit and is known by personnel. In some scenarios, cavalry units suffer extreme attrition in the first days of continuous operations, yet they are cited as prime candidates for reconstitution to return the survivors quickly to battle.

*j.* Combat stress control support is inexpensive and offers great potential pay-off in RTD soldiers at critical times and places in the battle and for reconstitution support after the battle.

(1) If not required to treat BF casualties and attrited units, the same few personnel will be active in consultation to unit leaders. This preventive consultation could reduce BF and improve the potential RTD of unit members if anyone should become a BF casualty.

(2) Combat stress control assets also assist with treatment of other WIA and DNBI cases who have rapid RTD potential. Many of these will also have severe BF symptoms which require treatment.

(3) Finally, CSC personnel have a crucial role in preventing PTSD in troops (including those who did not become casualties) by assisting command with after-action debriefings.

### **B-7. Combat Stress Control Planning Considerations in Operations Other Than War**

a. In OOTW, the total requirement for CSC support is significantly less than in war. There is less need to pre-position CSC elements far forward except during specific operations which approach war.

(1) The total ratio of BF cases to WIA cases may still be high, but the average number of WIA cases is less than two per thousand per day, so there are fewer cases. Most BF cases can be managed in their units as DUTY or REST cases.

(2) Few of the cases are HOLD or REFER casualties who need to be held under medical observation, so the BF casualty: WIA ratio is usually less than 1:10. However, relatively more of those who are casualties will need stabilization on a hospital ward.

(3) Reconstitution support is still important for units following battle, but the units will usually be small (squad, platoon, company).

b. Contingency operations pose special problems if they involve rapid deployment to an undeveloped theater. The CHS plan for care of all wounded and sick who cannot return immediately to full duty may be to evacuate them as quickly as possible to the nearest COMMZ- or CONUS-based MTFs. The tendency will be to err on the side of caution and evacuate anyone whose status is in doubt.

(1) This zero-day evacuation policy may continue for the duration of a brief operation or until formal medical-holding facilities can be deployed behind the forward area surgical teams.

(2) Early deploying medical personnel, as well as CSC planners and treaters, must make a concerted effort to encourage units to keep soldiers with DUTY BF in small units and to keep REST cases in their own CSS elements for a day or two of light duty, then return them to full duty.

(3) If at all possible, the plan should also hold BF casualties at the forward medical facilities for 1 to 3 days of restoration as an exception to the usual evacuation policy. This holding can be done under very austere conditions and need not add significant additional logistical burden to the system. Failure to provide such inexpensive, proximate treatment will greatly increased chronic psychiatric disability among soldiers.

c. In OOTW, while the need for restoration of BF casualties is less than during war, the incidence of misconduct stress behaviors increases, specifically—

- Behavior disorders, including indiscipline and violations of the Law of Land Warfare and the UCMJ.
- Drug and alcohol abuse.
- Other disorders of boredom and loneliness.

There is still a need for a reconditioning program in the corps to salvage those cases who do not improve in the divisions. In conflict, it may be practical to increase the evacuation policy for these cases, extending the policy from 7, 14, or 30 days; this maximizes RTD and minimizes the development of an evacuation syndrome, where



stress symptoms, misbehavior, or drug and alcohol misuse become a “ticket home.” Increasing the length of stay increases the reconditioning program census. The preventive consultation programs remain important for corps-level CSS units with no mental health sections.

*d.* Conflict requires rigorous preventive programs and after-action debriefings to minimize subsequent PTSD. These are especially important because of the ambiguous and often vicious aspects of enemy tactics and their effects on our soldiers.

#### **B-8. Considerations When Units or Individual Soldiers Redeploy Home (After Military Operations)**

*a.* Unit mental health personnel and supporting mental health/CSC units assist leaders in preparing soldiers for the transition back to garrison or civilian life. A period of several days should be scheduled for memorial ceremonies, group debriefings, and discussions of—

- What has happened in combat, especially working through painful memories.
- What to expect in the soldiers’ own reactions on returning to peacetime.
- How family and society may have changed since deployment and how to deal with these changes constructively.

*b.* More intensive programs are scheduled for individuals or units with prolonged intensive combat or other adverse experiences. Coordination with the rear detachment and family support groups is required to schedule similar education briefings and working-through sessions at the home station, both before the unit

returns and in combined sessions after the return. The debriefings should also address—

- How the service member, spouse, children, and society may have changed.
- How to cope with those changes positively.

Welcome home ceremonies and memorial services provide a sense of completion and closure.

#### **B-9. Combat Stress Control Planning Considerations in Peacetime**

*a.* To be effective, CSC must form a continuum with the Army mental health services. The peacetime utilization and training of mental health personnel must prepare them for their mobilization missions and develop strong unit cohesion among themselves and with supported units. Future operations may leave little time for on-the-job-training or to develop familiarity and cohesion before the crucial battle starts.

*b.* Army Regulation 40-216 states that patient care duties must not interfere with the division mental health section’s training with its division.

*c.* Echelon III psychiatric and mental health personnel who will provide CSC support should have peacetime duties which bring them into close working relationships with the organic mental health sections, chaplains, line commanders, and NCOs of the units they will support in war.

(1) Active Component CSC personnel should be assigned to MEDDACs. They will work in the following areas:

- Community mental health/community counseling centers.

- Drug and alcohol abuse prevention and control programs.
- Family advocacy and exceptional family member programs.

The CSC personnel should be working at the posts or garrisons of the Active Component divisions, brigade, regiments, and corps units they will support during war and OOTW. They should also participate with those units in field training exercises.

(2) Reserve Component CSC personnel should train with units they will support on mobilization. They should also use available training time to establish and implement CSC programs in those units.

#### **B-10. Briefing the Combat Stress Control Plan**

a. Depending on the echelon, the CSC plan may be briefed to a senior medical commander or line commander for approval. In

some headquarters, the CSC planner may give the briefing. In others, it may be given by the unit surgeon as part of the overall CHS plan.

b. In any case, the CSC briefing must be short and simple. The senior commander does not need all the details which went into the analysis (although those details should be available, if asked for). The commander needs to know the "bottom line." What will it cost? What is the return, especially in reduced casualties and rapid RTD? What is the risk if it is not done?

c. Many commanders are highly knowledgeable about the nature and importance of combat stress reactions and home front issues. However, many others are not. The CSC briefing may have to overcome the prejudice that mental health (CSC) interventions are things that pamper the troops and ruin them for combat or just burden the unit with weaklings who would be better purged from the Army.

d. Educating the senior commander, using language he knows and understands, is the first essential step of CSC.

APPENDIX C

**MENTAL HEALTH PERSONNEL IN MILITARY POLICE CONFINEMENT FACILITY TEAMS**

**C-1. Confinement Facility Teams**

Military Police Confinement Facility Teams LA through LF have the mission to provide command, staff planning, and administrative and logistical support to a confinement facility for military prisoners. The guards for the facility are provided by an MP Guard Company (TOE 19667L000); one squad is sufficient to guard 50 prisoners.

**C-2. Teams LA, LB, LC, and LD**

Teams LA, LB, LC, and LD (administrative overhead teams) are designed to provide administration for facilities of 50, 150, 300, and 450 prisoners, respectively. They contain mental health officers, NCOs, and enlisted personnel as shown in Table C-1. The medical specialists (MOS 91B) shown are also listed as being part of the TOE section for mental hygiene.

*Table C-1. Teams LA, LB, LC, and LD Confinement Facility*

TEAM	# PRISONERS	SOCIAL WORK OFFICER 73A67	CLINICAL PSYCHOLOGIST 73B67	BEHAVIORAL SCIENCE SPECIALIST 91G	MEDICAL SPECIALIST 91B
LA	50	—	—	1 (E5)	1 (E4)
LB*	150	1 (1LT)	—	1 (E5) 1 (E4) 1 (E3)	1 (E4)
LC*	300	1 (CPT)	—	1 (E6) 2 (E5) 2 (E4) 1 (E3)	2 (E4)
LD*	450	1 (MAJ)	1 (CPT)	1 (E7) 2 (E6) 2 (E5) 2 (E4) 2 (E3)	1 (E5) 1 (E4)

\* TOE specifies "mental hygiene section."

**C-3. Mental Health Personnel**

The duties of the mental health and medical personnel are listed below:

- a. *Social Work Officer, MAJ, AOC 73A67.* The social work officer directs mental

hygiene activities; conducts prisoners' counseling functions; performs prisoner evaluations; assists in the development of training programs; and supervises the behavioral science specialist. He is responsible for monitoring the correctional treatment program for the prisoners. Each prisoner is evaluated and a correctional treatment

program is devised with continuous reevaluation as additional information becomes available. The following aspects of correctional treatment are considered and closely monitored: employment, training, education, medical condition, religious participation, off-duty activities, and family and financial problems. The social work officer identifies prisoners who need psychiatric evaluation and refers them to the clinical psychologist.

*b. Clinical Psychologist, CPT, AOC 73B67.* The clinical psychologist applies psychological principles through direct patient services to help prisoners adjust to the confinement environment; evaluates emotional disturbances and mental and behavioral disorders; and promotes effective mental health.

*c. Behavioral Sciences Noncommissioned Officers and Specialists.* The behavioral science specialists help prisoners adjust to the confinement environment, learn problem-solving techniques, and develop productive and acceptable behavior. They meet with the prisoner within 48 hours of in-processing, complete necessary records, and initiate a follow-up plan. They provide advice concerning the prisoners' record, conduct, attitude, and progress. They make recommendations concerning clemency, parole, restoration, custody, and job assignments.

*d. Emergency Treatment Noncommissioned Officer and Medical Specialist.* They provide routine sick call and emergency treatment to prisoners. They coordinate CHS for medical activities beyond their capabilities.

## APPENDIX D

## THE GENEVA CONVENTIONS AND COMBAT STRESS-RELATED CASUALTIES

### D-1. Special Relevance to Medical Combat Stress Control

a. This appendix reviews the relationship of the Geneva Conventions to CSC and treatment of combat stress-related casualties.

b. The provisions of the Geneva Conventions afford the wounded and sick, medical personnel, and medical units protected status. The time-proven principles of treating BF casualties is to treat them as soldiers, not as patients. The BF casualties are treated in a nonpatient care tactical setting. This arguably creates a clear tension, perhaps even a contradiction.

c. The issue of the right to Geneva Conventions protection depends not upon what the CSC treater tells the BF soldier but rather on several issues:

(1) Does the BF soldier's behavior and duty status, in fact, meet the standards set by Geneva Convention for the Amelioration of the Condition of Wounded and Sick in Armed Forces in the Field (GWS)? A patient who meets these standards is considered a privileged patient, that is, one who is not contributing to the combat efforts by virtue of disability.

(2) Does the CSC staff's behavior conform to the GWS standard as personnel who are solely engaged in the care of the sick and wounded?

(3) Does the physical appearance of the CSC personnel, tents, vehicles, and so forth, sufficiently identify them as medical and entitled to GWS protection for this to be more than a moot point on the dispersed, fast-moving, long-range battlefield?

d. The CSC commander and the chain of command will have to decide whether—

(1) To risk the loss of protected status of specific personnel, activities, or facilities in the CSC program by having them strictly adhere to the nonpatient treatment principles and operate the CSC unit as a truly nonmedical activity.

(2) To accept the possible loss of protected status by not marking the unit as medical or by camouflaging the unit. Even if the unit is in technical compliance with the GWS, protection status may be lost.

(3) To seek the full benefit of protected status by limiting the application of the treatment principles and instead operating the CSC unit as a visibly obvious medical facility. This is done at perhaps the price of some reduction in therapeutic effectiveness.

e. Whether the CSC activity is operated as either a visibly obvious medical facility or is camouflaged, CSC personnel and soldiers being treated must adhere to the provisions of the GWS. This is required for them to maintain their protected status and the protected status for other medical units with which they are associated.

f. The remainder of this appendix will discuss special considerations for CSC activities and the application of these options based on the definitive Geneva Conventions information found in FM 8-10.

### D-2. Special Considerations for Medical Combat Stress Control Activities

a. We will now reconsider the three questions raised in paragraph B-1(c) relating to

whether CSC activities are entitled to Geneva Conventions protection.

*b.* Issue #1: Do the battle-fatigued soldiers comply with the GWS criteria for patients?

(1) DUTY and REST cases of BF are clearly still combat soldiers and are not entitled to GWS status. They are still solely on their own unit's rolls. They can, therefore, perform any soldierly task, including offensive operations, without losing a protected status which they do not have. The treatment principle of treating them as soldiers is fully satisfied.

(2) HOLD and REFER BF cases may be told that they are "soldiers, not patients," but they are, in fact, medical patients. They are absent from their units because of a temporary disability that makes them unable to do their combat duties. They are receiving medical care and are under the control of medical personnel/units. As long as they are not set to performing tasks which contribute to the war effort, they fully meet the vague GWS criteria for a "sick and wounded" patient.

(3) To stay within the letter of the Geneva Conventions rules, the following limitations apply:

(a) Recovering BF casualty perform work projects only at and for medical units; for example—

- Filling sandbags and digging trenches for the medical unit's own protection only.

- Moving medical supplies, maintaining medical vehicles, and helping in the medical mess facility and laundry.

- Providing perimeter and air guard security for the medical unit only, not for the total base cluster.

(b) Round trip prerecovery visits to the unit are theoretically allowed, provided the visitors perform no combat-relevant work but only assist the CSC personnel in their rounds.

*c.* Issue #2: Does the CSC staff comply with the GWS criteria for protected medical personnel? That depends on what they do or do not do.

(1) To retain personal entitlement to Geneva Conventions privilege, CSC personnel, like medics, PVNTMED teams, and battalion aid stations, must—

(a) Not use weapons except to defend themselves and their patients when that defense is made necessary by enemy attack specifically directed at the medical facility.

(b) Not transport weapons or ammunition (except for the permissible personal small arms), nonmedical equipment, or combat-effective (nonpatient) troops.

(c) Not transport DUTY or REST BF cases or fully recovered BF casualties back to their units in CSC (medical) vehicles. Instead, call the unit to come for them.

(d) Not initiate offensive actions against the enemy.

(e) Not engage in labor which directly supports combat operations (as distinct from protecting or restoring health).

(2) If CSC personnel are rumored to do the above, that may endanger the Geneva Conventions status for all CSC personnel, if the

captors identify them specifically as CSC rather than simply as medical personnel.

*d. Issue #3:* Does the physical appearance of the CSC element sufficiently identify it as medical for it to benefit from theoretical privileged status? Combat stress control activities can be divided into—

(1) Combat stress control activities which take place in nonmedical units. Examples are—

- A CSC consulting team in its truck, visiting a line unit.

- A CSC reconstitution support team camped at the reconstitution site.

- A CSC reconditioning “cell” (team) attached to a corps CSS unit, providing ongoing treatment to the “REST BF casualty” who are performing limited therapeutic duty at that unit.

(a) The BF soldiers are, in fact, “soldiers” on DUTY status (however limited) and not “patients.” The BF casualty could perform work details for CS, CSS, and combat units in the vicinity under directions from those units (not CSC personnel). This includes pulling perimeter defense duty. They could be transported to and from work details in nonmedical vehicles.

(b) In this situation, the CSC unit provides the best “military tactical” therapeutic setting for the “REST” BF cases. The CSS vehicle, tents, and personnel themselves are not a legitimate target and, if captured, would still be eligible for the Geneva Contentions status of “retained personnel” rather than “prisoners of war,” provided they (collectively) have adhered to the rules for being medical noncombatants.

However, they do not confer immunity from attack to the legitimate target with which they are collocated, so they have no grounds for complaint if they suffer casualties.

(2) Combat stress control activities which are functioning as or with medical units, but under tactical circumstances where they are using camouflage, light discipline, perimeter watch, and not showing the distinctive emblem (red cross). Examples are—

- Combat stress control team tents/vehicles at a FSMC, under camouflage.

- The division fatigue center or a corps reconditioning center, separated somewhat from its supporting medical company or CSH, and camouflaged.

(a) Although the fatigue or reconditioning centers technically are “holding patients,” the tactical setting supports the therapeutic message that they are still soldiers receiving temporary rest and performing for a tactical medical unit, not a hospital.”

(b) The CSC personnel would not be legitimate targets and, if captured, would still have the status of “retained personnel,” provided they did not violate the limitation on medical noncombatants.

(c) They have little grounds to complain, however, if a fast-moving or distant enemy fails to recognize their protected status.

(3) Combat stress control activities which are collocated with medical units showing the red cross (as red on white and not under camouflage). Example: A corps reconditioning center which is intermixed with a CSH or medical holding company and well separated from any nonmedical units.

(a) To avoid possibly creating an appearance which might compromise the Geneva status of the other medical units which are under the red cross, the CSC units should show the red cross on all their tents and refrain from using camouflage.

(b) In this case, the BF soldiers can still be told that they are not “patients” but rather are on temporary fatigue or reconditioning duty. This duty is with the CSC unit as temporary medical soldiers. They could be provided with the armbands showing the small distinctive emblem which is given to litter bearers or other soldiers who are temporarily detailed to medical duties.

(c) Everyone must, of course, comply fully with the Geneva Conventions restrictions.

(d) Because of the substantial loss of military tactical atmosphere, this alternative is less desirable than locating slightly further away, closer to the nonmedical CSS units, and erecting camouflage. Issuing the armbands may still be helpful. The CSC personnel would also wear them in these situations.

e. In a conflict where the enemy does not respect the Geneva Conventions, the chain of command may decide that CSC activities will forego the claim to Geneva Conventions protection altogether.

(1) The distinctive emblem would not be shown at all.

(2) Recovering BF casualty could perform any military tasks they are capable of, under direct supervision of CSC personnel.

(3) Combat stress control vehicles could, if available, transport DUTY, REST, and

recovering and recovered BF casualties to their units.

(4) Combat stress control personnel could, when necessary, contribute directly to the general defense.

(5) They should still respect the Geneva status of enemy medical units which are identified as such and of enemy sick and wounded.

f. Combat Stress Control and Geneva Prisoners of War (GPW).

(1) Prisoners of war will not normally be brought to the attention of CSC elements at forward medical facilities unless they also have either wounds or disease, obvious signs of major NP disorders, or BF symptoms which resemble one of the above.

(a.) In WWI, it was noted that POW and EPW rarely showed dramatic “shell shock” symptoms. As with the wounded, there is a natural (if relative) relief from anxiety that comes from being relieved of the responsibility and danger of combat. Just being alive (having had your willingness to surrender be accepted) and having someone else make all decisions about where you go and what you receive is a big relief.

(b) It is also probable that language barriers and lack of concern for EPW “feelings” have left many psychiatric problems among EPW unreported. Probable symptoms include:

• Anxiety over how they will be treated.

• Shame, guilt, and depression at having failed their country by being captured (or “voluntarily” surrendered).



- Post-traumatic stress disorders related to the deaths of comrades, close calls with death, and horrible sights seen.

- Major psychiatric illness.

(2) If EPW are brought to CSC personnel for evaluation or are encountered by CSC, mental health section, or NP ward and consultation service personnel in the course of their consultation mission, the GPW requires that—

(a) The EPW receive the same stabilization for major, potentially life- or function-threatening mental illness as friendly soldiers receive. This will normally be provided on the NP ward of hospitals, with guards providing security as needed. Physical restraints can be used as needed, provided routine nursing care is protecting against injury and unnecessary discomfort.

(b) Treatment of EPW with adjustment disorders or PTSD symptoms will, of course, not aim to return them to combat duty but rather to help them adjust to their status as prisoners and minimize life-long disability following repatriation.

(c) Combat stress control/mental health personnel will not provide direct assistance to prisoner interrogation. This is the responsibility of military intelligence personnel. Combat stress control involvement could jeopardize Geneva-protected status.

(3) Combat stress control units should provide routine mental health consultation to EPW confinement facilities. This should include—

- Stress control advise to the command regarding the stressors of US

Army MP personnel and any allied or coalition personnel working at the confinement facility.

- Advise regarding the stressors and stress manifestation of the prisoners and how to best control them.

- Individual evaluation and intervention for guards or prisoners when indicated.

(4) If CSC personnel are themselves taken prisoner and are granted “retained personnel” status, they will—

- Provide NP/mental health support to the POW.

- Provide life-saving assistance, as requested, to enemy personnel.

- Remain true to the code of conduct for POW and not provide other aid, comfort, assistance, or propaganda to the enemy.

### D-3. The Law of War

The conduct of armed hostilities on land is regulated by the law of land warfare. This body of law is inspired by the desire to diminish the evils of war by: protecting both combatants and noncombatants from unnecessary suffering; safeguarding certain fundamental human rights of persons who fall into the hands of the enemy, particularly prisoners of war, the wounded and civilians; and facilitating the restoration of peace. The law of war places limits on the exercise of a belligerent’s power in the interest of furthering that desire. It requires that belligerents refrain from employing any kind or degree of violence which is not actually necessary for military purposes, and that they conduct hostilities with regard for the principles of humanity and chivalry.

a. *Sources of the Law of War.* The law of war is derived from two principal sources: treaties (or conventions), such as the Hague and Geneva Conventions; and customs, practices which by common consent and long established, uniform adherence have taken on the force of law (see FM 27-10). Under the Constitution of the United States, treaties constitute part of the supreme “Law of the Land” and thus must be observed by both military and civilian personnel. The unwritten or customary law of war is also part of the law of the United States and is binding upon the United States, citizens of the United States, and other persons serving this country (see DA Pam 27-1).

b. *The Geneva Conventions.* The United States is a party to numerous conventions and treaties pertinent to warfare on land. Collectively, these treaties are often referred to as the Hague and Geneva Conventions. Whereas it may generally be said that the Hague Convention concerns the methods and means of warfare, the Geneva Conventions concern the victims of war or armed conflict. The Geneva Conventions are four separate international treaties, signed in 1949, and are respectively entitled: “Geneva Convention for the Amelioration of the Condition of the Wounded and Sick in Armed Forces in the Field”; “Geneva Convention for the Amelioration of the Condition of Wounded, Sick and Shipwrecked Members of Armed Forces at Sea” (GWS Sea); “Geneva Convention Relative to the Treatment of Prisoners of War”; and “Geneva Convention Relative to the Protection of Civilian Persons in Time of War” (GC). The Conventions, with amendments, are extremely detailed and contain many provisions which are tied directly to the CHS mission.

#### D-4. Protection of the Wounded and Sick

The essential and dominant idea of the GWS is that the person of the soldier who has been

wounded or who is sick, and for that reason is out of combat, is from that moment protected. Friend or foe must be tended with the same care. From this principle, numerous obligations are imposed upon parties to a conflict.

a. *Protection and Care.* Article 12 of the GWS imposes several specific obligations regarding the protection and care of the wounded and sick.

(1) The first paragraph of Article 12, GWS, states “Members of the armed forces and other persons mentioned in the following Article, who are wounded or sick, shall be respected and protected in all circumstances.”

(a) The word “respect” means “to spare, not to attack,” whereas “protect” means “to come to someone’s defense, to lend help and support.” These words make it unlawful to attack, kill, ill-treat, or in any way harm a fallen and unarmed enemy soldier while at the same time imposing an obligation to come to his aid and give him such care as his condition requires.

(b) This obligation is applicable “in all circumstances.” The wounded and sick are to be respected just as much when they are with their own army or in no-man’s-land as when they have fallen into the hands of the enemy.

(c) Combatants, as well as noncombatants, are required to respect the wounded. The obligation also applies to civilians, in regard to whom Article 18 specifically states: “The civilian population shall respect these wounded and sick, and in particular abstain from offering them violence.”

(d) The GWS does not define what is meant by “wounded or sick”; nor has there ever been any definition of the degree of severity

of a wound or a sickness entitling the wounded or sick combatant to respect. Any definition would necessarily be restrictive in character and would thereby open the door to misinterpretation and abuse. The meaning of the words "wounded and sick" is thus a matter of common sense and good faith. It is the act of falling or laying down of arms because of a wound or sickness which constitutes the claim to protection. Only the soldier who is himself seeking to kill may be killed.

(e) The benefits afforded the wounded and sick extend not only to members of the armed forces but to other categories of persons as well, classes of whom are specified in Article 13, GWS. Even though a wounded person is not in one of the categories enumerated in the Article, we still must respect and protect that person. There is a universal principle which says that any wounded or sick person is entitled to respect and humane treatment and the care which his condition requires. Wounded and sick civilians have the benefit of the safeguards of the Geneva Conventions.

(2) The second paragraph of Article 12, GWS, provides that the wounded and sick "... shall be treated humanely and cared for by the Party to the conflict in whose power they may be, without any adverse distinction found on sex, race, nationality, religion, political opinions, or other similar criteria. . . ."

(a) Adverse distinctions of any kind are prohibited. Nothing can justify a belligerent into making any adverse distinction between wounded or sick who require his attention, whether they be friend or foe. Both are equal in their claims to protection, respect, and care. The foregoing is not intended to prohibit concessions, particularly with respect to food, clothing, and shelter, which acknowledge the different habits and background of the wounded and sick.

(b) The wounded and sick shall not be made the subjects of biological, scientific, or medical experiments of any kind which are not justified on medical grounds and dictated by a desire to improve their condition.

(c) The wounded and sick shall not willfully be left without medical assistance; conditions exposing them to contagion or infection shall not be created.

(3) The only reasons which can justify prioritized treatment are reasons of medical urgency. This is the only justified exception to the principle of equality of treatment of the wounded. For example, this means that EPW who are triaged as "immediate" must be cared for before our own wounded who have been triaged as "delayed".

(4) Paragraph 5 of Article 12, GWS, provides that, if we must abandon wounded or sick, we have a moral obligation to, "as far as military considerations permit," leave medical supplies and personnel to assist in their care. This provision is not related to the absolute obligation imposed by paragraph 2 to care for the wounded. A belligerent can never refuse to care for enemy wounded he has captured because adversary has abandoned them without medical personnel and equipment.

b. *Enemy Wounded and Sick.* The protections accorded the wounded and sick apply to friend and foe alike without distinction. Certain provisions of the GWS, however, specifically concern enemy wounded and sick. There are two provisions in the GPW which also apply to enemy wounded or sick because they generally apply to POW.

(1) Article 14 of the GWS states that persons who are wounded and then captured have the status of POW. However, that wounded soldier also needs treatment. Therefore,

a wounded soldier who falls into the hands of an enemy who is a party to the GWS and the GPW will enjoy protection under both Conventions until his recovery. The GWS will take precedence over the GPW where the two overlap.

(2) Article 16 of the GWS requires the tabulation and sending of information regarding enemy wounded, sick, or dead.

*c. Search For and Collect Casualties.* Article 15 of the GWS imposes a duty on combatants to search for and collect the dead and wounded and sick as soon as circumstances permit. It is left to the tactical commander to judge what is possible and to decide to commit his medical personnel to this effort. If circumstances permit, an armistice or suspension of fire should be arranged to permit this effort.

*d. Assistance of the Civilian Population.* Article 18, GWS, is the only one therein which addresses the civilian population. It allows a belligerent to ask the civilian to collect and care for wounded or sick of whatever nationality. This provision does not relieve the military authorities of their responsibility to give both physical and moral care to the wounded and sick. The GWS also reminds the civilian population that they must respect the wounded and sick and must not injure them.

*e. Enemy Civilian Wounded and Sick.* Certain provisions of the Geneva Conventions are relevant to the CHS mission.

(1) Article 16 of the Geneva Conventions provides that enemy civilians who are “wounded and sick, as well as the infirm, and expectant mothers, shall be the object of particular protection and respect.” The Article also requires that, “As far as military considerations allow, each Party to the conflict shall *facilitate* the steps taken to search for the killed and wounded [civilians], to assist . . . other

persons exposed to grave danger, and to protect them against pillage and ill-treatment [emphasis added].”

(a) The “protection and respect” to which wounded and sick enemy civilians are entitled is the same as that accorded to wounded and sick enemy military personnel.

(b) While Article 15 of the GWS requires parties to a conflict to search for and collect the dead and the wounded and sick members of the armed forces. Article 16 of the Geneva Conventions states that the parties must “facilitate the steps taken” in regard to civilians. This recognizes the fact that saving civilians is the responsibility of the civilian authorities rather than that of the military. The military is not required to provide injured civilians with medical care in a CZ. However, if we start providing treatment, we are bound by the provisions of the GWS. Provisions for treating civilians (enemy or friendly) will be addressed in COMMZ regulations.

(2) In occupied territories, the Occupying Power must accord the inhabitants numerous protections as required by the Geneva Conventions. The provisions relevant to medical care include—

- The requirement to bring in medical supplies for the population if the resources of the occupied territory are inadequate.

- A prohibition on requisitioning medical supplies unless the requirements of the civilian population have been taken into account.

- The responsibility of ensuring and maintaining, with the cooperation of national and local authorities, the medical and hospital establishments and services, public health, and hygiene in the occupied territory.

- The requirement that medical personnel of all categories be allowed to carry out their duties.

- A prohibition on requisitioning civilian hospitals on other than a temporary basis and then only in cases of urgent necessity for the care of military wounded and sick and after suitable arrangements have been made for the civilian patients.

- The requirement to provide adequate medical treatment to detained persons.

- The requirement to provide adequate medical care in internment camps.

#### D-5. Protection and Identification of Medical Personnel

Article 24 of the GWS provides special protection for “Medical personnel *exclusively engaged* in the search for, or the collection, transport, or treatment of the wounded or sick, or in the prevention of disease, [and] staff *exclusively engaged* in the administration of medical units and establishments . . . [emphasis added].” Article 25 provides limited protection for “Members of the armed forces specially trained for employment, should the need arise, as hospital orderlies, nurses, or auxiliary stretcher-bearers, in the search for or the collection, transport, or treatment of the wounded and sick . . . *if they are carrying out those duties at the time when they come into contact with the enemy or fall into his hands* [emphasis added].”

a. *Protections.* There are two forms of protection, and they are separate and distinct.

(1) The first is protection from intentional attack if medical personnel are identifiable as such by an enemy in a combat

environment. Normally, this is facilitated by medical personnel wearing an arm band bearing the distinctive emblem (a red cross or red crescent on a white ground) or by their employment in a medical unit, establishment, or vehicle (including medical aircraft and hospital ships) that displays the distinctive emblem. Persons protected by Article 25 may wear an arm band bearing a miniature distinctive emblem only while executing medical duties.

(2) The second protection provided by the GWS pertains to medical personnel who fall into the hands of the enemy. Article 24 personnel are entitled to “retained person” status. They are not deemed to be POW, but otherwise benefit from the protection of the 1949 Geneva Convention Relative to the Treatment of Prisoners of War. They are authorized to carry out medical duties only, and according to Article 28, GWS, “shall be retained only in so far as the state of health . . . and the number of prisoners of war require.” Article 25 personnel are POW, but shall be employed on their medical duties in so far as the need arises. They may be held until a general repatriation of POW is accomplished upon the cessation of hostilities.

b. *Specific Cases.* Some medical personnel may fall into each of the categories identified in Articles 24 and 25, depending on their duties at the time.

(1) While only Article 25 refers to nurses, nurses are Article 24 personnel if they meet the “exclusively engaged” criteria of that Article.

(2) The AMEDD officers and non-commissioned officers serving in positions that do not meet the “exclusively engaged” criteria of Article 24 are not entitled to its protection but, under Article 25, are entitled to protection from intentional attack during those in which they are performing medical support functions. Examples

of medical personnel who would not meet the “exclusively engaged” criteria of Article 24 are—

(a) The AMEDD officers serving as commanders of FSBs with responsibility for base/base cluster defense as well as command and control of medical and nonmedical units.

(b) The AMEDD officers and noncommissioned officers serving in staff positions within the FSB with responsibility for planning and supervising the logistics support for a combat maneuver brigade.

(c) A medical company commander, a physician, or the executive officer, an MS officer, detailed as convoy march unit commander with responsibility for medical and nonmedical unit routes of march, convey control, defense, and repulsing attacks.

(d) Medical Service officers and other Army officers and warrant officers who are qualified helicopter pilots but who are not permanently assigned to a dedicated medical aviation unit. These officers devote part of their time to flying medical evacuation missions but primarily fly helicopters not bearing red cross markings on standard combat missions.

(e) The GWS does not preclude the use of AMEDD personnel in perimeter defense of nonmedical units. While manning the perimeter defense of nonmedical units, AMEDD personnel would forfeit their special protected status under Article 24 of the GWS. They would be subject to being intentionally attacked, and if captured, would be POW and not necessarily allowed to perform any medical duties. If they had returned to their medical duties, they would possibly be entitled to the protection of Article 25, GWS. That is, if identifiable as performing medical duties, they would not be subject to intentional attack, and if captured, would be allowed to perform medical duties as needed.

c. *Identification Cards and Arm Bands.* Medical personnel who meet the “exclusively engaged” criteria of Article 24, GWS, are entitled to wear an arm band bearing the distinctive emblem of the red cross and carry the medical personnel identification card authorized in Article 40, GWS (in the US armed services, DD Form 1934). Article 25 personnel and medical personnel serving in positions that do not meet the “exclusively engaged” criteria of Article 24 are not entitled to carry the medical personnel identification card or wear the distinctive emblem arm band. Such personnel carry a standard military identification card (DD Form 2A) and under Article 25, may wear an arm band bearing a miniature distinctive emblem when executing medical duties.

#### **D-6. Protection and Identification of Medical Units and Establishments, Buildings and Material, and Medical Transports**

a. *Protection.* There are two separate and distinct forms of protection.

(1) The first is protection from intentional attack if medical units, establishments, or transports are identifiable as such by an enemy in a combat environment. Normally, this is facilitated by medical units or establishments flying a white flag with a red cross and by marking buildings and transport vehicles with the emblem.

(a) It follows that if we cannot attack recognizable medical units, establishments, or transports, we should allow them to continue to give treatment to the wounded in their care, as long as this is necessary.

(b) All vehicles employed exclusively on medical transport work are protected on the field of battle. Vehicles being used for

both military and medical purposes, such as ambulances being used to move wounded personnel during an evacuation and carrying retreating belligerents as well, are not entitled to protection.

(c) Medical aircraft, like medical transports, are protected from intentional attack but with a major difference: They are protected only "while flying at heights, times and routes specifically agreed upon between the belligerents concerned." Article 36, GWS. Such agreements may be made for each case or may be of a general nature, concluded for the duration of hostilities. If there is no agreement, belligerents will be able to use medical aircraft only at their own risk and peril.

(d) The second paragraph of Article 19 imposes an obligation upon belligerents to "ensure that the said medical establishments and units are, as far as possible, situated in such a manner that attacks against military objectives cannot imperil their safety." Hospitals should be sited alone, as far as possible from military objectives. The unintentional bombardment of a medical establish or unit due to its presence among or proximity to valid military objectives is a violation of the GWS. Legal protection is certainly valuable but it is more valuable when accompanied by practical safeguards.

(2) The second protection provided by the GWS pertains to medical units, establishments, material, and transports which fall into the hands of the enemy.

(a) Captured mobile medical unit material is to be used first to treat the patients in the captured unit. If there are no patients in the unit, or when those who were there have been moved, the material is to be used for the treatment of other wounded and sick persons.

(b) Generally the buildings, material, and stores of fixed medical establishments will continue to be used to treat wounded and sick. However, after provision is made to care for remaining patients, tactical commanders may make other use of them. All distinctive markings must be removed if the buildings are to be used for other than medical purposes.

(c) The material and stores of fixed establishments and mobile medical units are not to be intentionally destroyed, even to prevent them from falling into enemy hands. The actual buildings may in certain extreme cases have to be destroyed for tactical reasons.

(d) Medical transport which falls into enemy hands may be used for any purpose once the medical care of the wounded and sick they contain is otherwise provided for. The caveat as to removal of distinctive marking applies here also.

(e) Medical aircraft are supposed to obey a summons to land for inspection. If it is performing its medical mission, it is supposed to be released to continue its flight. If examination reveals that an act "harmful to the enemy" (such as if the aircraft is carrying munitions) has been committed, it loses the protections of the Conventions and may be seized. If a medical aircraft makes an involuntary landing, all aboard, except the medical personnel, will be POW. A medical aircraft refusing a summons to land is a fair target.

*b. Identification.* The GWS contains several provisions regarding the use of the red cross emblem on medical units, establishments, and transports (the identification of medical personnel has been previously discussed in paragraph D-5).

(1) Article 39 of the GWS reads as follows: "Under the direction of the competent

military authority, the emblem shall be displayed on the flags, armlets, and on all equipment employed in the Medical Service. ”

(a) There is no obligation on a belligerent to mark his units with the emblem. Sometimes a commander (generally no lower than a brigade commander for US forces) may order the camouflage of his medical units in order to conceal the presence or real strength of his forces. The enemy must respect a medical unit if he knows of its presence, even one which is camouflaged or not marked. The absence of a visible red cross emblem, however, coupled with a lack of knowledge on the part of the enemy as to the unit’s protected status, may render that unit’s protection valueless.

(b) The distinctive emblem is not a red cross alone: it is a red cross on white ground. Should there be some good reason, however, why an object protected by the Conventions can be marked only with a red cross without a white ground, belligerents may not make the fact that it is so marked a pretext for refusing to respect it.

(c) Some countries use the red crescent or the red lion and sun on a white ground in place of the red cross. Those emblems are recognized as authorized exceptions under Article 38, GWS.

(d) The initial phrase of Article 39 shows that it is the military commander who controls the emblem and can give or withhold permission to use it; moreover, he alone can order a medical unit to be camouflaged. He is at all times responsible for the use made of the emblem and must see that it is not improperly used by the troops or by individuals.

(2) Article 42 of the GWS specifically addresses the marking of medical units and establishments:

(a) "The distinctive flag of the Convention shall be hoisted only over such medical units and establishments as are entitled to be respected under the Convention, and only with the consent of the military authorities," paragraph 1, Article 42, GWS. Although the Convention does not define "the distinctive flag of the Convention," what is meant is a white flag with a red cross in its center. Also, the word "flag" must be taken in its broadest sense. Hospitals are often marked by one or several red cross emblems painted on the roof. Finally, the military authority must consent to the use of the flag (Article 39) and must ensure that the flag is used only on buildings entitled to protection.

(b) "In mobile units, as in fixed establishments, [the distinctive flag] may be accompanied by the national flag of the Party to the conflict to which the units or establishment belongs," paragraph 2, Article 42, GWS. This provision makes it optional to fly the national flag with the red cross flag. On a battlefield, the national flag is a symbol of belligerency and is therefore likely to provoke attack.

#### D-7. Loss of Protection of Medical Units and Establishments

Medical assets lose their protected status by committing acts "harmful to the enemy," Article 21, GWS. If such an act occurs, a warning must be given to the offending unit and a reasonable time allowed to cease such activity.

a. *Acts Harmful to the Enemy.* The phrase "acts harmful to the enemy" is not defined in the Conventions but should be considered to include acts the purpose or effects of which are to harm the enemy, by facilitating or impeding military operations. Such harmful acts would include the use of a hospital as a shelter for able-bodied combatants, as an arms or ammunition dump, or as a military observation post. Another



instance would be the deliberate siting of a medical unit in a position where it would impede an enemy attack.

*b. Warning and Time Limit.* The enemy has to warn the unit to put an end to the harmful acts and must fix a time limit, at the conclusion of which he may open fire or attack if the warning has not been complied with. The phrase "in all appropriate cases" recognizes that there might obviously be cases where a time limit could not be allowed. A body of troops approaching a hospital and met by heavy fire from every window would return fire immediately.

#### **D-8. Conditions Not Compromising Medical Units and Establishments of Protection**

*a.* Article 22 of the GWS reads as follows: "The following conditions shall not be considered as depriving a medical unit or establishment of the protection guaranteed by Article 19:

"(1) That the personnel of the unit or establishment are armed, and that they use the arms in their own defense, or in that of the wounded and sick in their charge.

"(2) That in the absence of armed orderlies, the unit or establishment is protected by a picket or by sentries or by an escort.

"(3) That small arms and ammunition taken from the wounded and sick and not yet handed to the proper service, [sic] are found in the unit or establishment.

"(4) That personnel and materiel of the veterinary service are found in the unit or establishment, without forming an integral part thereof.

"(5) That the humanitarian activities of medical units and establishments or of their personnel extend to the care of civilian wounded or sick."

*b.* These five conditions are not to be regarded as acts harmful to the enemy. These are particular cases where a medical unit retains its character as such and its right to immunity, in spite of certain appearances which might have led to the contrary conclusion or at least created some doubt.

*c.* A medical unit is granted a privileged status under the laws of war. This status is based on the view that medical personnel are not combatants and that their role in the combat area is exclusively a humanitarian one. In recognition of the necessity of self-defense, however, medical personnel may be armed for their own defense or for the protection of wounded and sick under their charge. To retain this "privileged status," they must refrain from all aggressive action and may employ their weapons only if attacked in violation of the Conventions. They may not employ arms against enemy forces acting in conformity with the laws of war and may not use force to prevent the capture of their unit by the enemy. (It is, on the other hand, perfectly legitimate for a medical unit to withdraw in the face of the enemy.) Medical personnel who use their arms in circumstances not justified by the law of war expose themselves to penalties for violation of the law of war and, provided they have been given due warning to cease such acts, may also forfeit the protection of the medical unit or establishment which they are protecting.

(1) Medical personnel may carry only small arms, such as rifles or pistols or authorized substitutes.

(2) The presence of machine guns, grenade launchers, booby traps, hand grenades.

light antitank weapons, or mines in or around a medical unit or establishment would seriously jeopardize its entitlement to privileged status under the GWS. The deliberate arming of a medical unit with such items could constitute an act harmful to the enemy and cause the medical unit to lose its protection regardless of the location of the medical unit. See the previous discussion of loss of protection of medical units.

*d.* Guarding of medical units, as a rule, is performed by its own personnel. However, it will not lose its protected status if the guard is performed by a number of armed soldiers. The military guard attached to a medical unit may use its weapons, just as armed orderlies may, in order to ensure the protection of the unit. But, as in the case of orderlies, the soldiers may act only in a purely defensive manner and may not oppose the occupation or control of the unit by an enemy who is respecting the unit's privileged status. The status of such soldiers is that of ordinary members of the armed forces. The mere

fact of their presence with a medical unit will shelter them from attack. In case of capture, they will be POW.

*e.* Wounded arriving in a medical unit may still be in possession of small arms and ammunition, which will be taken from them and handed to authorities outside the medical unit. Should a unit be visited by the enemy before it is able to get rid of these arms, their presence is not of itself cause for denying the protection to be accorded the medical unit under the GWS.

*f.* The presence with a medical unit of personnel and material of the Veterinary Corps is authorized, even where they do not form an integral part of such unit.

*g.* Establishments protected by the GWS may take in civilians as well as military wounded and sick without jeopardizing their privileged status. This clause merely sanctions what is actually done in practice.

## ★APPENDIX E

**MEDICAL REENGINEERING INITIATIVE FOR MENTAL  
HEALTH AND COMBAT STRESS CONTROL ELEMENTS  
IN THE THEATER OF OPERATIONS****Section I. OVERVIEW OF CHANGES****E-1. Unit Mental Health Sections***a. Divisions.*

(1) *Comparison.* The Medical Force 2000 (MF2K) had a consolidated division mental health section assigned to the MSMC of the MSB. The division mental health section was staffed with a psychiatrist, a social work officer, a clinical psychologist, and enlisted mental health specialists. Doctrine for MF2K specified that the division mental health section send a mental health officer/NCO team to each maneuver brigade upon deployment. The MRI decentralized the division mental health section, making a behavioral science officer and a mental health specialist organic to each FSMC. Under the MRI, the psychiatrist and the NCOIC remain in the MSMC and will continue to have staff responsibilities to the division surgeon. The psychiatrist and the NCOIC provide mobile consultation in the division rear, technical supervision to the brigade-level sections and medical personnel, and clinical expertise at the MSMC.

(2) *Implications.* Division assignment policy, not TOE structure, must ensure that the FSB medical companies supporting the three maneuver brigades receive one social work officer and one clinical psychologist as brigade mental health officers. The third brigade can receive either AOC. Doctrine and policy must ensure that the division psychiatrist, the mental health NCOIC, the brigade behavioral science officers, and the mental health specialists continue to function in an integrated and coordinated CSC program. This ensures that all three mental health disciplines/expertise are available throughout the division. This is facilitated in garrison where all division mental health assets will work together and provide clinical care for division soldiers and their families. On deployment, division mental health personnel will continue to work together using telecommunication, electronic transmission, and automated data processing (“telemedicine”).

*b. Area Support Medical Battalion.*

(1) *Comparison.* The MF2K had a centralized mental health section assigned to the headquarters and support company. This section was similar to the division mental health section except it only had two officers (a psychiatrist and a social worker). The reorganization of the ASMB under MRI replaces the headquarters and support company with a headquarters detachment. The headquarters detachment provides C2 for the battalion. Under this MRI design, the headquarters detachment can locate with any of its four ASMCs. Each ASMC will have a behavioral science officer and a mental health specialist assigned. The behavioral science officer position may be filled with either a social worker or a clinical psychologist. The ASMC mental health section provides mobile support to all units in its area of responsibility, as well as clinical expertise for the ASMCs. Assigned to the ASMB headquarters detachment is a psychiatrist and two mental health specialists. The psychiatrist continues to provide staff advice to the battalion headquarters and technical supervision and clinical expertise for all the ASMCs (mental health sections). All of the enlisted mental health specialists assigned to the battalion are E-4 or below.

## C 1, FM 8-51

(2) *Implications.* When deployed, the ASMB psychiatrist and the ASMC behavioral science officers may not have the opportunity for close contact depending on the ASMB's mission and the size of the AO. All ASMB mental health sections must be proactive by providing consultation and by teaching stress reduction techniques. Battalion medical personnel must understand the principles of CSC prevention, treatment, and the different medical/surgical diagnoses that must be ruled out. The absence of mental health NCOs in the battalion to supervise and mentor the enlisted mental health specialists makes it essential that each section's behavioral science officer and mental health specialist work together in peacetime. They should work together in a field training environment as well as a clinical environment in garrison. All the mental health personnel assigned to the battalion must learn to make good use of telemedicine among themselves and with supported units.

### c. *Armored Cavalry Regiment and Separate Brigades.*

(1) *Comparison.* In MF2K, the ACR had no organic mental health personnel. Separate brigades had only enlisted mental health personnel in their medical company. The MRI gives these units a mental health section which is the same as those found in division medical companies. The behavioral science officer (AOC 67D00) assigned to the ACR or separate brigade FSMCs may be either a social worker or a clinical psychologist.

(2) *Implications.* These mental health sections will receive technical training and supervision from a psychiatrist only when they come under the operational control of a division or are located in the corps under the ASMB psychiatrist's area of responsibility. The behavioral science officer assigned to the ACR should actively seek out training assistance from the ASMB or the division psychiatrist. He should seek this assistance to ensure that regiment/brigade mental health and other medical personnel are fully trained in the medical aspects of CSC triage and stabilization.

## E-2. **Combat Stress Control Units**

### a. *Medical Detachment, Combat Stress Control.*

(1) *Comparison.* In MF2K, the 23-person CSC detachment was designed to be the corps-level package to augment the organic mental health section of a division during war. Although highly mobile and designed to break up into widely dispersed teams, the detachment was totally dependent on the division and/or its higher medical headquarters for administrative and logistical support. Assigned to the headquarters section was a psychiatrist who was also a full-time clinician in one of the forward-deployed teams and an NCOIC with a clinical rather than an administrative background. A light-wheeled vehicle mechanic was added later. Since the first CSC detachment was activated, these units have provided CSC support to their home posts. They have supported field training exercises while concurrently deploying teams or entire detachments on 5- to 12-month rotations to Somalia, Haiti, Guantanamo (Cuba), Bosnia, and Hungary. These missions demonstrated the need for additional clinical and headquarters personnel to conduct highly flexible, split-based operations. In MRI, the CSC detachment increases to 43 persons (without increasing total CSC personnel in the corps) by transferring from the CSC companies some of the corps-level CSC mission support requirements and the assets to accomplish them. Each CSC detachment gains one 4-person CSC preventive team (for a total of four), one 10-person CSC fitness team (for a total of two), and five new headquarters personnel.

(2) *Implications.* The MRI CSC detachment retains the mission of providing direct support to a division's maneuver brigades and general/reinforcing support to the DSA, including corps units in those areas. In addition, the detachment now augments area support in the corps immediately behind the division. It can provide reconstitution support for a brigade- or smaller-sized unit; it can conduct the corps-level reconditioning program, when needed, for the division and corps slice. The bill payer is a reduced number of CSC companies and detachments in the force structure. The detachment must function with its elements widely dispersed, some working in and for the supported division and others working in the corps for the medical group/brigade. The CSC detachment headquarters must coordinate these CSC support operations. In the corps, the MRI CSH no longer has a 15-person NP ward and consultation service. Under MRI, it has a small 4-person NP consultation section (psychiatrist, psychiatric nurse, two mental health specialists) to provide psychiatric stabilization on medical wards; to provide triage and outpatient psychiatry; and to provide stress control support (including debriefings) for all the hospital patients and staff. The CSC detachment will have an increased requirement to provide CSC support at the CSHs. Under some circumstances, the CSC detachment may be required to provide a CSC fitness team to conduct ward-level stabilization, in addition to other higher priority CSC mission requirements.

*b. Medical Company, Combat Stress Control.*

(1) *Comparison.* In MF2K major regional conflicts, the 85-person CSC companies had responsibility for all CSC support in the corps area, plus major responsibility for supporting and reinforcing the CSC detachments. The detachments were usually entirely within the division areas, although "spare teams" might come under the CSC company's C2 for reallocation to areas of special need. There was no CSC unit allocation to support the COMMZ. In the COMMZ, the field hospital's 15-person NP ward, OT, and psychology personnel provided the required Level 4 reconditioning. The general hospital's NP ward personnel provided NP stabilization or detoxification to assure safe air evacuation of psychiatric patients or RTD for recovered patients. The MF2K COMMZ hospitals could reinforce the COMMZ ASMB's mental health section in the event of serious rear battle or disaster. Under the MRI, the hospitals retain only the 4-person NP consultation section. While the MRI CSC detachments take over the forward corps and Level 3 reconditioning mission, the one remaining CSC company is still responsible for the corps rear and has additional mission responsibilities for the echelons above corps (COMMZ). Each remaining CSC company, therefore, increases to 88 persons with the gain of two 4-person CSC preventive teams and the retention of its four CSC fitness teams (previously labeled restoration teams in MF2K). Each CSC company loses five 2½- or 5-ton trucks from its CSC fitness and headquarters sections, plus three maintenance personnel. The trucks and maintenance personnel were lost because of Armywide rules for vehicles in rear area units. Two more of the headquarters section's personnel were also deleted. The CSC company loses 50 percent of its weapons for self-defense.

(2) *Implications.* The CSC company still has a high-mobility multipurpose wheeled vehicle with trailer for each preventive and fitness team and the commander to perform daily consultation missions. It is dependent on other units to move its large tents and cots. This could be time-urgent in some reconstitution support missions. The CSC company should use the one remaining large truck in its headquarters to practice load planning and to develop loading plans for unit equipment being transported by other units. All the CSC sections could use this vehicle for training and familiarization of loading plans which would enhance their movement operations. The CSC company still provides CSC preventive teams for direct support of corps-level brigades (National Guard enhanced readiness brigades, ACRs, field artillery,

aviation, combat engineers, military police, and so forth) which may deploy as far forward as the divisions' brigades. The company augments the ASMB/ASMC mental health mission in the corps rear and provides routine support to brigade-sized units refitting in or transitioning through the corps. The company must remain able to assemble task-organized elements quickly to provide reconstitution support for a division- or smaller-sized unit. If Level 4 reconditioning is indicated after several weeks of intensive battle, the CSC company can provide a CSC fitness team and perhaps a CSC preventive team. One inpatient NP ward in the theater may be judged more efficient to stabilize psychiatric patients for air evacuation at a time of heavy casualties. This would prevent their presence from disrupting the functions of the busy medical/surgical wards. This capability could be achieved by attaching at least one CSC fitness team to a hospital. However, this should only be a temporary measure because the fitness team will have other CSC support requirements. The capability of staffing a psychiatric ward, which is no longer organic to any deploying MRI hospital, can also be required in stability operations and support operations, as it was at Guantanamo for 11 months. Finally, a new mission for the CSC company and hospital NP personnel is the DOD (Health Affairs) requirement to screen all US soldiers for mental health problems prior to redeployment from a TO. This can require brief interviews of up to 20 percent of the redeploying population.

*c. Medical Companies and Detachments, Combat Stress Control.*

*(1) Comparison.*

*(a)* In MF2K, the command positions were officially open only to psychiatrists, although exceptions were made in practice. In MRI, the TOE specifies that command is now open to "best qualified" officers of the other mental health disciplines (65A, 66C, 73A, 73B) as well as the psychiatrists (60W). This is in keeping with the general trend within the Army Medical Department. Number constraints still require the commander of the CSC detachment to be dual-hatted as a practicing clinician in one of the teams.

*(b)* In MF2K, psychiatrists were in the preventive section, usually deployed further forward, while clinical psychologists were in the restoration (now fitness) section, usually employed further to the rear. The commander could transfer personnel between sections to meet mission needs. In MRI, the clinical psychologists are in the preventive section and the psychiatrists are in the fitness section. This results in a net decrease in psychiatrists and a larger proportional increase in psychologists.

*(2) Implications.* The switching of the psychiatry and psychology positions was made as an "economy of force measure," rather than because of any change in the mission demands at each echelon. It is projected that the Army will not have sufficient psychiatrists to fill all CSC unit positions. The CSC mission still recognizes the FSMC as the key point for making the differential triage between combat stress/BF cases and similar-appearing patients with significant medical or surgical conditions. Putting triage expertise as far forward as feasible is especially important in chemical warfare scenarios or on a widely dispersed and mobile high-technology battlefield. The psychiatrists in the CSC units must now make special effort to train the psychologists and social workers in the preventive section on basic physical/neurological examinations and to convey relevant findings or suspicions to the physicians and physician assistants. The psychiatrists must use telemedicine to support their forward deployed CSC preventive teams and must be prepared to deploy forward themselves when needed. The division psychiatrists must increase training to all

the forward-deployed physicians and physician assistants, as well as the brigade behavioral science officers, as there will be fewer psychiatrists forward to assist in combat NP triage.

## **Section II. UNIT MENTAL HEALTH SECTIONS IN THE THEATER OF OPERATIONS**

### **E-3. Location and Assignment of Unit Mental Health Sections**

Mental health sections are located in the divisions, the corps, and echelons above corps. In the divisions, a mental health section is assigned to each medical company. In the corps and echelons above corps, mental health sections are assigned to each of the ASMCs. In ACRs and separate brigades, they are assigned to the medical company.

### **E-4. Utilization in Garrison**

In garrison, mental health personnel assigned to the division or brigade units should be employed as mental health care providers. They should provide their consultation skills and specialty clinical expertise to division personnel and their families. When the medical company and its supported units deploy on training exercises or are in the field, assigned mental health personnel will deploy with them to provide CSC training and support. In addition, they will train to perfect their own technical and tactical skills. In garrison, referrals to the hospital or its clinics should be reduced. This is accomplished by having each of the mental health sections working closely with units leaders and chaplains as consultants. In this capacity, they can provide intervention and teach stress management. They can evaluate and treat distressed soldiers at their duty stations or unit areas. However, the mental health sections of the division must continue to operate a consolidated division mental health activity in which all division mental health officers and enlisted personnel work together. The consolidated division mental health activity ensures that case management of problem soldiers/patients receive the benefit of all three mental health disciplines (psychiatrist, psychologist, and social worker) represented in the division for diagnosis, treatment, and referral. The consolidated division mental health activity provides the environment for cross training and building of team cohesion. Additionally, enlisted mental health personnel receive multidisciplinary training and supervision. All three mental health disciplines contribute fully in operational planning and in the division preventive psychiatry program, to include family support group development, drug and alcohol prevention and control, and personnel reliability screening. On some posts, the division mental health assets may augment table of distribution and allowances personnel in the Community Mental Health Activity. This would be the usual mode for the behavioral science officers and mental health specialists/mental health sections of the ASMB and companies of ACRs or separate brigades.

### **NOTE**

In accordance with AR 40-216, clinical responsibilities in garrison must not interfere with participation in field exercises, deployment exercises, and maintenance of combat readiness.

## **C 1, FM 8-51**

### **E-5. Division Mental Health Sections**

One CSC/mental health section as stated above is organic to each medical company assigned to the division. The medical companies are a DISCOM asset (see FMs 8-10-1, 8-10-3, and 63-21). The FSMCs are units assigned to the FSBs which support the maneuver brigades. The MSMC in the MSB is located in the DSA.

#### **NOTE**

The responsibilities of the division mental health section extends to all division elements and provides a mental health/CSC presence at the combat maneuver brigades.

The mental health sections are the medical elements in the division with the primary responsibility for assisting the command with controlling combat stress. Combat stress is controlled through sound leadership, assisted by CSC training, consultation, and restoration programs conducted by these sections. Division and brigade mental health sections enhance unit effectiveness and minimize losses due to BF, misconduct stress behaviors, and NP disorders. All mental health sections assigned or attached to the division work under the technical control and direction of the division psychiatrist. The division psychiatrist, acting for the division surgeon, has staff responsibility for establishing policy and guidance for the prevention, diagnosis, treatment, and management of NP, BF, and misconduct stress behavior cases within the division AO. He also has technical responsibility for the psychological aspect of surety programs. The staff of the division mental health sections provides training to unit leaders and their staffs, chaplains, medical personnel, and troops. The staff monitors morale, cohesion, and mental fitness of supported units. Other responsibilities for the mental health sections located in divisions include—

- Monitoring indicators of dysfunctional stress in units.
- Evaluating NP, BF, and misconduct stress behavior cases.
- Providing consultation and triage as requested for medical/surgical patients exhibiting signs of combat stress or NP disorders.
- Supervising selective short-term restoration for HOLD category BF casualties (1 to 3 days).
- Coordinating support activities of attached corps-level CSC elements.

The division psychiatrist normally uses the DSA clearing station as a base of operations. A behavioral science officer (AOC 67D00) is assigned to each medical company except those which have the psychiatrist assigned. Each behavioral science officer assigned to a FSMC is designated as the brigade behavioral science health officer. The mental health specialist (MOS 91X00) assigned to each FSMC is designated as brigade CSC coordinator. The division psychiatrist oversees the activities of all mental health sections in the division and provides consultation, as necessary.

### **E-6**



*a. Mental Health/Combat Stress Control Support.* The division psychiatrist provides input to the division surgeon on CSC-related matters. He works with the division medical plans and operations personnel to monitor and prioritize mental health support missions in accordance with the division CHS OPLANs or OPORDs. Coordination for mental health personnel augmentation is accomplished through the division surgeon.

*b. Mental Health Sections.* When the brigades are tactically deployed, the mental health sections use the division clearing stations operated by the FSMCs as the center of their operations but are mobile throughout the AO. The section's priority functions are to sustain combat effectiveness, prevent unnecessary evacuations, and to coordinate RTD, not to treat cases. The mental health section provides technical supervision for the attached CSC preventive team from the corps CSC detachment. Through the brigade surgeons, this section keeps abreast of the tactical situation and plans and projects requirements for CSC support when units are pulled back for rest and recuperation.

*c. Division Mental Health Staff Activities.* Mental health sections will coordinate their activities with the division psychiatrist. The division psychiatrist synchronizes mental health/CSC activities for the division's prevention, training, and treatment responsibilities. Behavioral science officers using their multidisciplinary mental health professional expertise will—

- Supervise and train the mental health specialists.
- Provide mental health/CSC staff input to the commands within the division AO.
- Guarantee clinical evaluation and supervision of treatment for all NP and problematic BF cases before they leave the division.
- Maintain communications and unity of efforts for the division and brigades.
- Provide points of contact to integrate reinforcing CSC teams throughout the division.

(1) *Psychiatrist.* The division psychiatrist (MAJ, MC, AOC 60W00) is the officer responsible for overseeing the division mental health program. The psychiatrist is also a working physician who applies the knowledge and principles of psychiatry and medicine in the treatment of all patients. He examines, diagnoses, and treats, or recommends courses of treatment for personnel suffering from emotional or mental illness, situational maladjustment, BF (combat stress reactions), and misconduct stress behaviors. His specific functions include—

- Directing the division's mental health (combat mental fitness) program.
- Being a staff consultant for the division surgeon on matters having psychiatric aspects, which include—
  - The personnel reliability program.
  - Security clearances.

## C 1, FM 8-51

- Alcohol and drug abuse prevention and control programs.
- Planning CSC support for supported units.
- Conducting mental health/CSC operations.
- Providing staff consultation for the MSMC commander and for supported commands within the division.
- Being responsible for assuring the diagnosis, treatment, restoration, and disposition of all NP and problematic BF cases.
- Participating in the diagnosis and treatment of the sick, injured, and wounded, especially those who can RTD quickly.
- Providing consultation and training to physicians, physicians assistants, unit leaders, chaplains, and other medical personnel regarding diagnosis, treatment, and management of BF, misconduct stress behavior, and NP disorders.
- Prescribing treatment and disposition for soldiers with NP conditions.
- Providing supervision and training of assigned and attached mental health personnel.

(2) *Behavioral science officer.* A behavioral science officer (CPT, AOC 67D00) is assigned to the mental health section of each FSMC. He serves as brigade behavioral science officer for the supported brigade and the BSA. The behavioral science officer participates in staff planning to represent and coordinate mental health/CSC activities throughout the brigade. The behavioral science officer is especially concerned with assisting and training—

- Small unit leaders.
- Unit ministry teams.
- Battalion medical platoons.
- Patient-holding squad and treatment squad personnel of the FSMC.

The behavioral science officer provides training and advice in the control of stressors, the promotion of positive combat stress behaviors, and the identification, handling, and management of misconduct stress behavior and BF soldiers. He coordinates training and support to the brigade through the FSMC commander and division psychiatrist. He collects and records social and psychological data and counsels personnel with personal, behavioral, or psychological problems. The general duties of the behavioral science officer include—

- Assisting in a wide range of psychological and social services.

- Compiling caseload data.
- Providing counseling to soldiers experiencing emotional or social problems.
- Referring soldiers to specific mental health officers, physicians, or agencies when indicated.
- Assisting with group debriefings, counseling, and therapy sessions, and leading group discussions.
- Providing individual case consultation to commanders, NCOs, chaplains, battalion surgeons, and physician assistants within the supported brigade.
- Collecting information from units regarding unit cohesion and morale which include—
  - Obtaining data on disciplinary actions.
  - Collecting information with questionnaires.
  - Conducting structured interviews.
  - Collecting information on individual BF cases pertaining to the prior effectiveness of the soldier, precipitating factors causing the soldier to have BF, and the soldier's RTD potential.

#### NOTE

Behavioral science officer positions, AOC 67D00, may be filled by a clinical psychologist, AOC 73B67, or a social work officer, AOC 73A67.

(3) *Clinical psychologist.* The clinical psychologist (CPT, MS, AOC 73B67) assists in the development, management, and supervision of the division's mental health (combat mental fitness) program. His specialty responsibilities apply to the knowledge and principles of psychology, to include—

- Evaluating the psychological functioning of soldiers.
- Conducting surveys and evaluating data to assess unit cohesion and other factors related to prediction and prevention of both BF casualties and misconduct stress behaviors.
- Performing psychological and neuropsychological testing to evaluate psychological problems and psychiatric and organic mental disorders, and to screen misconduct stress behaviors and unsuitable soldiers.

## C 1, FM 8-51

- Apprising unit leaders, primary care physicians, and other clinical personnel regarding the assessment of individual and unit mental health fitness programs.
- Providing consultation for unit commanders and CSC/mental health personnel working at the brigade level regarding problem cases.
- Counseling and providing therapy or referral for soldiers with psychological problems.
- Serving as the brigade mental health officer for one maneuver brigade (normally teamed with a behavioral science NCO).

(4) *Social work officer.* The social work officer (CPT, MS, AOC 73A67) assists in the development, management, and supervision of the division's mental health (combat mental fitness) program. He applies the mental health principles and his knowledge of social work in the performance of his duties. His responsibilities include—

- Evaluating the social integration of BF and misconduct stress behavior soldiers in their units and families.
- Coordinating and ensuring the RTD of recovered stress casualties and their reintegration into their original or new units.
- Identifying and resolving organizational and social environmental factors which interfere with combat readiness.
- Ensuring support for soldiers and their families from Army and civilian community support agencies.
- Apprising unit leaders, primary care physicians, and other clinical personnel of available social service resources.
- Providing consultation to unit commanders and to division mental health section personnel regarding problem cases.
- Counseling and providing therapy or referral for soldiers with emotional disorders and psychological problems.
- Serving as brigade behavioral science officer for one maneuver brigade as a member of the mental health section of the FSMC.

(5) *Senior mental health noncommissioned officer.* The mental health NCO (E-7, MOS 91X40) is located with the division psychiatrist in the DSA. This senior NCO assists the division psychiatrist with the accomplishment of his duties. He is the CSC coordinator for the DSA. His specific duties include—

- Keeping the division psychiatrist informed on the status of the mental health sections and on the mental fitness of soldiers supported in the DSA.
- Monitoring, facilitating, and coordinating training activities of the division mental health personnel.
- Monitoring and coordinating situation reports from division mental health sections.
- Coordinating with the supporting CSC medical detachment for additional mental health support, as required.
- Supervising restoration of BF casualties in the DSA.
- Conducting classes on selected mental health topics for senior NCOs within the division.

(6) *Mental health specialist.* The mental health specialist (E-4, MOS 91X10) is assigned to the mental health section of each FSMC. He works under the supervision of the behavioral science officer. The mental health specialist assists the behavioral science officer with the accomplishment of his duties. The mental health specialist is the CSC coordinator for the supported maneuver brigade and the BSA. His specific duties include—

- Keeping the behavioral science officer informed on the status and mental fitness of soldiers in the supported brigade and in the BSA.
- Assisting the behavioral science officer with facilitating and coordinating training activities of the ASMB mental health personnel.

#### **E-6. Area Support Medical Battalion Mental Health Sections**

The ASMB's mental health sections are the medical elements with primary responsibility for assisting units in the corps support area to control combat stress. As in the division, combat stress is controlled through vigorous prevention, consultation, and restoration programs. These programs are designed to maximize the RTD rate of BF soldiers by identifying combat stress reactions and providing rest/restoration within or near their unit areas. Also, the prevention of post-traumatic stress disorders is an important objective in both division and corps CSC programs. Under the direction of the ASMB psychiatrist, the mental health sections provide mental health/CSC services throughout the ASMB's AO. The battalion mental health sections are assigned to the headquarters and headquarters detachment of the ASMB. Also, each ASMC has a mental health section. The battalion psychiatrist has staff responsibility for establishing policy and guidance for the prevention, diagnosis, and management of NP, BF, and misconduct stress behavior cases seen by ASMB physicians and the mental health sections. He also has technical responsibility for the psychological aspect of surety programs. He provides and oversees mental health and stress control training for unit leaders and their staffs, chaplains, medical personnel, and troops. Through the battalion and company mental health sections, the battalion psychiatrist monitors morale, cohesion, and mental fitness of supported units. He has

## C 1, FM 8-51

technical control over all mental health personnel assigned to the ASMB and provides guidance as required for the successful accomplishment of their responsibilities. These responsibilities include—

- Providing command consultation and making recommendations for reducing stressors.
- Evaluating NP, BF, and misconduct stress behavior cases.
- Providing consultation and triage, as requested, for patients exhibiting signs of combat stress reactions or mental disorders.
- Providing selective short-term restoration for HOLD category BF cases.
- Coordinating support activities with the medical company and detachment and CSC elements, when attached or in support of the ASMB.

*a. Mental Health Support.* The ASMB S3 and battalion mental health sections monitor and prioritize mental health support missions in coordination with the MEDCOM/brigade headquarters.

*b. Battalion Mental Health Section Staff.* The ASMB mental health section is staffed as shown in Figure E-1. The dispersion of multidisciplinary mental health professionals throughout the battalion ensures that expertise is present to—

- Train and supervise the mental health specialists.
- Provide staff input to supported commands.
- Provide clinical evaluation and appropriate treatment or referral for all NP and problematic BF cases.
- Provide a mental health professional for interface with supported brigades, groups, and corps resources.
- Provide rapid assistance with critical incident/events debriefing for the ASMB's area of responsibility.

### MENTAL HEALTH SECTION STAFF

Psychiatrist (MAJ, AOC 60W00)  
Mental Health Specialist (E-4, MOS 91X10)  
Mental Health Specialist (E-3, MOS 91X10)

*Figure E-1. Area support medical battalion mental health section.*

(1) *Psychiatrist.* The psychiatrist (MAJ, MC, AOC 60W00) is the section leader. The psychiatrist is also a working physician who applies the knowledge and principles of psychiatry and medicine in the treatment of all patients. He examines, diagnoses, and treats, or recommends courses of treatment for personnel suffering from emotional or mental illness, situational maladjustment, combat stress reaction, BF, and misconduct stress behaviors. His areas of responsibility include—

- Implementing CSC support according to the battalion's area CHS plan.
- Coordinating and conducting mental health/CSC operations.
- Providing staff consultation for the ASMB commander and for supported commands within the supported AO. This includes the personnel reliability program, security clearances, and ADAPCPs.
- Training and mentoring ASMC medical and mental health personnel in neurological and mental status examinations and differential diagnosis of stress and psychiatric disorders from general medical/surgical conditions.
- Diagnosing, treating, and determining disposition of NP, BF, and misconduct stress behavior cases.
- Participating in the diagnosis and treatment of the sick, injured, and wounded, especially of those who can RTD quickly.
- Providing consultation and training to unit leaders, chaplains, and medical personnel regarding identification and management of BF (combat stress reaction), misconduct stress behaviors, and NP disorders.
- Providing therapy or referral for soldiers with NP conditions.
- Providing supervision and training of assigned and attached mental health and CSC personnel.
- Coordinating with the supporting CSC medical detachment for additional mental health support as required.

(2) *Mental health specialists.* The mental health specialists (E-4 and E-3, MOS 91X10) are located with the ASMB psychiatrist at the ASMB headquarters. These mental health specialists assist the ASMB psychiatrist with the accomplishment of his duties. They may perform as CSC coordinators for selected units in the corps support area. Their specific duties include—

- Keeping the ASMB psychiatrist informed on the status of the mental health sections and on the mental fitness of soldiers supported in the corps support area.
- Assisting the psychiatrist with facilitating, and coordinating training activities of the ASMB mental health personnel.

- Monitoring and coordinating situation reports from ASMC mental health sections.
- Conducting initial screening evaluations of patients.

*c. Area Support Medical Company Mental Health Section.* Each ASMC mental health staff consists of a behavioral science officer and a mental health specialist (Figure E-2). The mental health specialist assists the behavioral science officer with the accomplishment of his duties. The behavioral science officer participates in staff planning to represent and coordinate mental health/CSC activities throughout the AO. The behavioral science officer and mental health specialist are especially concerned with assisting and training—

- Small unit leaders.
- Unit ministry teams and staff chaplains.
- Battalion medical platoons.
- Patient-holding squad and treatment squad personnel of the ASMC.

**AREA SUPPORT MEDICAL COMPANY  
MENTAL HEALTH SECTION STAFF**

Behavioral Science Officer (CPT, AOC 67D00)  
Mental Health Specialist (E-3, MOS 91X10)

*Figure E-2. Area support medical company mental health section.*

The ASMC mental health section provides training and advice in the control of stressors, the promotion of positive combat stress behaviors, and the identification, handling, and management of misconduct stress behavior and BF soldiers. It coordinates CSC training for supported units through the ASMC commander and battalion psychiatrist, as required. The section collects and records social and psychological data and counsels personnel with personal, behavioral, or psychological problems. General duties for personnel assigned to this section include—

- Assisting in a wide range of psychological and social services.
- Providing classes in stress control.
- Compiling caseload data.
- Providing counseling to soldiers experiencing emotional or social problems.



- Referring soldiers to specific hospital NP services or CSC unit facilities, physicians, or agencies when indicated.
- Conducting or facilitating group debriefings, counseling, and therapy sessions, and leading group discussions.
- Providing individual case consultation to commanders, NCOs, chaplains, battalion surgeons, and physician assistants within the supported AO.
- Collecting information from units regarding unit cohesion and morale which include—
  - Obtaining data on disciplinary actions.
  - Collecting information with questionnaires.
  - Conducting structured interviews.
  - Collecting information on individual BF cases pertaining to the prior effectiveness of the soldier, precipitating factors causing the soldier to have BF, and the soldier's RTD potential.

The company mental health section uses the ASMC clearing station as the center for its operations but is mobile throughout the AO. The section's priority functions are to promote positive stress behaviors, prevent unnecessary evacuations, and coordinate RTD, not to treat cases. Through the ASMC commander, the section keeps abreast of the tactical situation and plans and projects requirements for CSC support when units are pulled back for rest and recuperation.

#### **E-7. Mental Health Personnel in the Armored Cavalry Regiments and Separate Brigades**

In the ACRs, active components, and National Guard-enhanced separate brigades, both light and heavy, mental health personnel are assigned to the medical company, separate brigade. A behavioral science officer and a mental health specialist are assigned to the mental health section of each FSMC. They serve as the behavioral science officer and CSC coordinator for the brigade and the BSA. Their duties and responsibilities are the same as described for the division FSMC mental health section described above. They receive technical supervision from the division psychiatrist, when attached to a division, or from the ASMB psychiatrist in their units' AO in the corps and echelons above corps.

### **Section III. COMBAT STRESS CONTROL COMPANY**

#### **E-8. Medical Company, Combat Stress Control (TOE 08467A000)**

The CSC medical company is employed in the corps and echelons above corps. The basis of allocation is one CSC medical company per corps or theater. The CSC medical company is task-organized, METT-T

## C 1, FM 8-51

dependent for stability operations and support operations. Medical company, CSC, TOE 08467A000 replaces Medical Company, CSC, TOE 08467L000.

*a. Mission.* A CSC medical company provides comprehensive preventive and treatment services to a corps and echelons above corps during war. It provides this support to all services on an area support basis. The CSC medical company provides direct support to separate maneuver brigades or CS brigades, as needed. It reinforces or reconstitutes other CSC assets in the corps or divisions as needed. The CSC medical company provides CSC/mental health services to indigenous populations as directed in stability operations or support operations, to include domestic support operations, humanitarian assistance, disaster relief, and peace support operations. The comprehensive support provided by the CSC medical company entails all of the six CSC functional mission areas. The CSC functional missions areas are discussed in Chapter 1.

*b. Capabilities.* At TOE Level 1, the CSC medical company provides—

- Advice, planning, and coordination for CSC to commanders.
- Combat stress control reconstitution support for units up to division size.
- Preventive and CSC fitness teams (4 to 10 personnel) for consultation, treatment services, and reconstitution support for up to battalion-sized organizations.
- Restoration or reconditioning programs for up to 50 soldiers per CSC fitness team on an area basis.
- Deployment of CSC elements to forward areas for support of contingency operations.

*c. Assignment.* The Medical Company, CSC (TOE 08467A000) is assigned to a corps or theater MEDCOM. Elements of this TOE may be further attached to a corps medical brigade or to an ASMB.

*d. Organization.* The CSC medical company is organized into a headquarters section, a preventive section, and a CSC fitness section. The company is dependent on appropriate elements of the MEDCOM or medical brigade for administrative and medical logistical support, medical regulating, BF casualty delivery, and medical evacuation. The company is dependent on appropriate elements of the corps or COMMZ for finance, legal, personnel and administrative services, food service, supply and field services, supplemental transportation, and local security support services. When CSC medical company elements or teams are deployed to division areas, they are dependent on the division medical companies (such as the MSB medical company or the FSB medical company) for patient accounting, transportation, food service, and field service support.

*e. Employment.* The CSC medical company is employed in all intensities of conflict when a corps with two or more divisions is deployed. Task-organized CSC elements are deployed for division-size combat operations, stability operations and support operations, and other contingency operations which are METT-T dependent.

(1) The CSC preventive and CSC fitness sections together provide all five mental health disciplines. These resources are flexibly task-organized in a variety of combinations to meet the fluid CSC threat at different phases in the operations. Personnel may be quickly cross-attached from one section to another to accommodate the shifting work load and to provide reconstitution support packages.

(2) The CSC preventive and CSC fitness sections both organize into teams. Combat stress control preventive or CSC fitness teams deployed forward of the corps boundaries in support of tactical operations come under operational control of the CHS operations element in the supported units. These teams will also come under technical control of the division or brigade CSC teams.

(3) One or more of the CSC medical company's eight CSC preventive teams may locate at the FSMC when deployed in direct support of separate brigades or ACRs.

(4) One or more of the four (10-person) CSC fitness teams may reinforce ASMCs which are deployed to locations throughout the corps and echelon above corps. These teams provide a basis for CSC prevention and intervention. The teams may conduct restoration programs at the ASMCs, as required. These teams may also be deployed forward to provide temporary augmentation/reinforcement, as required.

(5) Based on work load, one or more of the four CSC fitness teams, plus one or more CSC preventive teams, locate with a echelon above corps hospital where they conduct Level 4 CSC reconditioning programs, as required. A hospital located in the corps rear or the COMMZ is the best location to conduct the theater CSC reconditioning program. When deployed with a hospital, these teams provide mobile consultation in the vicinity of the hospital. These teams are also prepared to restrict reconditioning programs and deploy forward in support of higher priority missions on very short notice. These teams can also augment hospital NP services by staffing a temporary NP ward.

(6) The CSC medical company is divisible into four functionally emulative increments for split-based operations, stability operations and support operations, as assigned.

(7) Nonstandard task elements for specific missions can be organized using any combination of the CSC preventive section and CSC fitness section personnel to meet specific mental health needs. For stability operations and support operations, the minimum is an officer/NCO team to supplement a brigade CSC team or a CSC preventive module/team of two officers, one NCO, and one enlisted. These modules may be augmented with personnel from the CSC fitness section to add additional specialty expertise.

## **E-9. Headquarters Section**

The headquarters section provides C2 and unit-level administrative and maintenance support to its subordinate sections when they are collocated with the company. The headquarters section may also provide assistance to detached elements by making site visits if the elements are within a feasible distance for ground transportation. The CSC medical company elements normally deploy with limited maintenance capability. When these CSC elements deploy, they are dependent on the supported units for patient accounting, transportation, food service, and field services. The personnel assigned to the headquarters section includes a—

## C 1, FM 8-51

- Company commander.
- Chaplain.
- Medical operations officer.
- First sergeant.
- Mental health NCO.
- Supply sergeant.
- Patient administrative NCO.
- Nuclear, biological, and chemical NCO.
- Decontamination specialist.
- Personnel administrative specialist/unit clerk.
- Administrative specialist.
- Unit supply specialist/armorer.
- Patient administrative specialist.
- Light-wheeled vehicle mechanic.
- Power generation equipment repairman.
- Cook.

Personnel from the headquarters section are deployed with teams or task-organized CSC elements, as required.

*a. Company Commander.* The company commander, a psychiatrist or other clinical officer (LTC, MC/MS/AN/SP, AOC 60W00/73A67/73B67/66CTT/65A00) performs normal C2 and supervisory functions. The commander is also responsible for the training, discipline, billeting, and security of the company. He provides daily reports to his higher headquarters as established by the TSOPs and corps reporting procedures. He serves as the NP consultant on the staff of the medical group. As a psychiatrist, he coordinates with command and unit physicians regarding care and disposition of BF casualties and NP patients. He exercises clinical supervision over all treatment provided by the CSC sections and detachments. He performs physical and mental status evaluations in emergency or command evaluation situations; this includes diagnosing, prescribing initial treatment, and determining disposition. The commander interfaces with higher and supported headquarters and with supported CSC medical detachments, ASMB mental

health sections, and division mental health sections. He keeps informed on CSC operations through daily reports and by frequent visits to task-organized CSC elements deployed from his company.

*b. Chaplain.* The chaplain (CPT, CH, AOC 56A00) provides religious/ethical education and perspective to the dispersed sections for the prevention and treatment of BF and misconduct stress behaviors. He interfaces CSC activities with unit ministry teams in maneuver units, with hospital chaplains, and with staff chaplains at each headquarters level. The chaplain usually accompanies the CSC medical company commander when he visits supported units and task-organized CSC elements deployed in support of those units. The chaplain has a chaplain's kit to conduct services but is without a chaplain's assistant. The chaplain's primary role is to aid other chaplains and CSC personnel in preventing stress control and in working with BF casualties and misconduct stress behaviors. In addition to his coordination, liaison, and training duties, he provides religious support to BF casualties and to staff as available time and support requirements permit.

*c. Medical Operations Officer.* The medical operations officer (CPT, MS, AOC 70B67) is the principal assistant to the company commander on all matters pertaining to the tactical employment of company assets. He is responsible for overseeing operations and administrative, supply, and maintenance activities within the company. His responsibilities also include—

- Coordinating administrative activities with the staff of the higher medical headquarters.
- Ensuring unit operations and communications security.
- Keeping the commander current on the corps' and supported divisions' tactical situations.
- Assisting the commander with development of CSC support estimates and plans.
- Planning and scheduling unit training activities.
- Coordinating movement orders and logistical support for deployed company elements.

*d. First Sergeant.* The first sergeant (E8, MOS 91B5M) serves as the principal enlisted assistant to the company commander. He manages the administrative activities of the CP. He supervises the company activities of the unit clerk and maintains liaison between the commander and assigned NCO. He provides guidance to enlisted members of the company and represents them to the commander. He plans, coordinates, supervises, and participates in activities pertaining to organization, training, and combat operations for the company. He assists the company commander in the performance of his duties. The first sergeant also assists the medical operations officer and performs the duties of an operations NCO.

*e. Mental Health Noncommissioned Officer.* The mental health NCO (E7, MOS 91X40) assists the commander and chaplain as required. He performs surveys and collects information on stress and stressors in supported units. He also checks the status of recovered stress casualties.

*f. Supply Sergeant.* The supply sergeant (E-6, MOS 92Y30) requests, receives, stores, safeguards, and issues general supplies. He determines methods of obtaining relief from responsibility for

## C 1, FM 8-51

lost, damaged, and destroyed supply items. He maintains the company supply records, supervises unit supply operations, and maintains accountability for all equipment organic to the company.

*g. Patient Administration Noncommissioned Officer.* The patient administration NCO (E-5, MOS 71G20) is responsible for managing patient statistics of all BF casualties seen by the company element. He is normally located with the company headquarters but makes visits to task-organized CSC elements as required to ensure company elements are complying with patient administrative requirements. He is responsible for forwarding the Medical Summary Report (RCS Med-302 [R3]) in accordance with AR 40-400 and ensures that all BF casualty accountability and status reports are forwarded as directed by higher headquarters. He initiates the FMC (DD Form 1380) on all BF casualties seen for consultation and medical treatment and those placed in the center for restoration or reconditioning programs. He ensures that all restoration and reconditioning centers maintain the Daily Disposition Log. He supervises subordinate patient administrative specialists. He coordinates transportation and evacuation, as required, for BF casualties sent rearward for additional restoration or reconditioning and for recovered BF casualties returning to their units.

*h. Nuclear, Biological, and Chemical Noncommissioned Officer.* The NBC NCO (E-5, MOS 54B20) coordinates NBC defense operations for the company. He supervises the training that pertains to procedures and techniques of NBC defense. The NBC NCO predicts the effects of weather and terrain on chemical operations. His responsibilities also include preparing predictions on nuclear fallout and on NBC downwind hazards. He prepares and evaluates NBC reports and computes expected radiation effects affecting personnel, equipment, and operations. This NBC NCO is the technical advisor to the unit commander on matters pertaining to NBC functions. He provides expertise and training in the operation and maintenance of NBC equipment. He supervises decontamination of unit equipment, supplies, and personnel (not patients). At a time of heavy caseloads (unless the unit is in an active NBC environment), the NBC NCO may serve as a squad leader for up to ten BF casualties in reconditioning or restoration.

*i. Decontamination Specialist.* The decontamination specialist (E-4, MOS 54B10) assists the NBC NCO with the accomplishment of his duties. The decontamination specialist may serve as squad leader for up to ten BF casualties in reconditioning or restoration.

*j. Personnel Administrative Specialist/Unit Clerk.* The unit clerk (E4, MOS 75B10) provides and coordinates personnel and administrative support to company personnel and maintains unit administrative records. He advises the commander and coordinates personnel actions for recovering BF casualties or RTD soldiers that require other administrative actions. He prepares and processes recommendations for awards and decorations and arranges for awards ceremony. For complete description of duties, see AR 611-201.

*k. Administrative Specialist.* The administrative specialist (E-4, MOS 71L10) prepares military and nonmilitary correspondence in draft and final copy. He employs basic principles of English composition and grammar in preparing correspondence. He prepares registered or certified mail for dispatch. He opens, sorts, routes, and delivers incoming correspondence and messages. He prepares suspense control documents and maintains suspense files. The administrative specialist prepares and maintains functional files according to Modern Army Record-keeping System. He receives publications and establishes and maintains the publications library. He requisitions and stocks blank forms.

*l. Unit Supply Specialist/Armorer.* The unit supply specialist/armorer (E-4, MOS 92Y10) performs duties involving general supply, including inventorying, requisitioning, distribution, and storage. He assists the supply sergeant with the accomplishment of his duties. In addition to general supply duties, the supply specialist maintains the weapons storage area, issues and receives munitions, and performs small arms unit maintenance. He assists the supply sergeant with general supply activities and operates the vehicle assigned to the supply element.

*m. Patient Administration Specialist.* The patient administration specialist (E-4, MOS 71G10) participates in the in-processing of BF casualties into restoration and reconditioning centers. He is responsible for initiating reports and forms identified in the preceding paragraph. He maintains the Daily Disposition Log. When deployed with a CSC fitness team or task-organized CSC elements, he works with the patient administration section of the medical unit to which the task-organized CSC element or CSC fitness team is attached. Through the patient administration section of the unit they are attached to, they coordinate BF casualty evacuation and transportation requirements. He maintains his assigned vehicles and operates company radios. He coordinates the disposition of BF casualties through supporting unit communications assets. Patient administration specialists deploy with CSC fitness teams or task-organized CSC elements.

*n. Light-Wheeled Vehicle Mechanic.* The light-wheeled vehicle mechanic (E-4, MOS 63B10) performs organizational maintenance, PMCS, and repairs on gasoline and diesel-fueled, light-wheeled vehicles. Light-wheeled vehicles include prime movers designated as 5 tons or less and their trailers and associated items. Duties of the light-wheeled vehicle mechanic include—

- Diagnosing malfunctions of light-wheeled vehicles and associated items.
- Troubleshooting engine/equipment problems using TMs, TMDE, and other equipment, as required.
- Applying applicable safety precautions.
- Performing scheduled maintenance and repairs on vehicles and equipment assisted by the vehicle operator.
- Maintaining and accounting for tools and equipment issued to him.
- Deploying with company element (task-organized CSC element) to provide maintenance for company or attached vehicles.
- Maintaining and requisitioning repair parts as required.
- Initiating and maintaining records on equipment use, operations, history, maintenance, modifications, and calibration.
- Requesting, receiving, recording, and storing parts and tools.

## C 1, FM 8-51

The light-wheeled vehicle mechanic is also responsible for—

- Providing input for the materiel readiness report.
- Assisting in the scheduling of maintenance and repair services.

### NOTE

When the light-wheeled vehicle mechanic deploys, he works with the maintenance section/element of the unit to which the task-organized CSC element is attached.

*o. Power Generation Equipment Repairman.* The power generation equipment repairman (E4, MOS 52D10) performs unit maintenance functions. The major functions and tasks of the repairman include—

- Applying applicable safety precautions.
- Inspecting equipment, determining category of maintenance and extent of repairs, and recording results.
- Classifying unserviceable components and assemblages as required.
- Performing PMCS on shop equipment.
- Maintaining and accounting for tools issued.
- Training unit personnel on how to properly operate and perform user maintenance on assigned generators.

*p. Cook.* One cook (E3, MOS 92G10) provides food service (tray-pack heating) for the company when it is assembled. More often, he is deployed with a task-organized CSC element and further attached with the food service section of the supported medical unit. He also trains CSC personnel on food tasks which may be used as a part of a CSC restoration or reconditioning program. He may serve as work group leader for BF casualties performing food service tasks as part of the BF casualty's treatment.

## E-10. Combat Stress Control Preventive Section

Personnel of this section are task-organized to prevent stress, misconduct, and prevent post-traumatic stress disorders. The CSC preventive section accomplishes this through command consultation, preventive education, critical events/incidences debriefings, staff planning, case evaluation, and triage, and counseling intervention at supported unit. Section personnel also supervise and participate in restoration and



reconditioning programs conducted by Echelon II medical unit and the CSC fitness section. Personnel from this section may be task-organized with personnel of the CSC fitness section into CSC elements for specific missions of the company. This section can divide into eight CSC preventive teams. The section (and team) leader position may be held by any of the officers assigned to the section. The CSC preventive section has six clinical psychologists, eight social work officers, two behavioral science officers, eight mental health NCOs, and eight mental health specialists assigned to the section. This section can divide into eight 4-person CSC preventive teams. Elements of the section may also be task-organized with elements of the restoration section to form task-organized CSC elements for deployment to conduct CSC operations. The company commander will appoint the CSC preventive team or task-organized CSC element leaders, considering rank, professional qualifications, and especially, experience. The preventive section's responsibilities include—

- Providing preventive consultation.
- Assisting units with REST category BF cases and RTD of recovered BF casualties.
- Providing NP triage and stabilization as required.
- Supervising restoration of category HOLD BF casualties by medical personnel.
- Providing medical, psychiatric, and social work expertise to restoration and reconditioning programs.
- Deploying CSC preventive teams to reinforce CSC elements operating in the divisions and corps areas.
- Providing reconstitution mental health support to physically and mentally exhausted units.

*a. Clinical Psychologists.* There are six clinical psychologists (MAJ [four], CPT [two], MS, AOC 73B67) assigned to the section. Their duties include—

- Providing diagnostic expertise for triage.
- Conducting psychological and neuropsychological testing.
- Providing behavioral treatment and counseling.
- Conducting and supervising surveys of unit cohesion, morale, and individual mental readiness for combat.
- Providing command consultation.
- Supervising subordinate personnel.
- Conducting and supervising critical event debriefings.

## C 1, FM 8-51

*b. Social Work Officers.* Eight social work officers (MAJ [four], CPT [four], MS, AOC 73A67) are assigned to this section. They provide proactive consultation, give individual and group counseling, supervise restoration/reconditioning, and coordinate RTD of recovered cases. They also provide staff advice and coordinate Army and civilian social services support. These social work officers may be divided among several task-organized CSC elements or be utilized as a member of a CSC preventive team. When deployed as a member of a CSC preventive team or task-organized CSC element, the social work officers' duties include—

- Evaluating psychosocial (unit and family) functioning of soldiers with BF and misconduct stress behavior.
- Coordinating and ensuring the return of recovered BF and NP soldiers to duty and their reintegration into their original or new unit.
- Identifying and resolving organizational and social environmental factors which interfere with combat readiness.
- Coordinating support for soldiers and their families through Army and civilian community support agencies, when possible.
- Apprising unit leaders, primary care physicians, and others health care providers of available social service resources.
- Providing consultation to supported unit commanders and to other mental health/CSC personnel regarding problem cases.
- Counseling and providing therapy or referral for soldiers with psychological problems.
- Conducting and supervising unit survey interviews and critical event debriefings.

*c. Behavioral Science Officers.* These two positions (CPT, AOC 67D00) are filled by AOC 73A67 or AOC 73B67. These officers perform the duties of their respective AOC and in the technical and tactical operations of the section. The behavioral science officers are responsible for direct supervision of the mental health NCOs and specialists assigned to the section. The behavioral science officers, assisted by the mental health NCOs, conduct the training activities of the section. They monitor and coordinate situation reports, conduct classes on stress control, and provide consultation for leaders of supported units.

*d. Mental Health Noncommissioned Officers.* There are eight mental health NCOs (E-5, MOS 91X20). Two of these NCOs act as assistant section sergeants and assist the behavioral science officers with the accomplishment of their duties. When deployed as a member of a CSC preventive team or task-organized element, these NCOs assume the position of team NCOIC and assist the team leader with the accomplishment of his duties. Their general duties include—

- Providing consultation and stress control education, especially to NCOs and enlisted personnel.

- Assisting in a wide range of psychological and social services.
- Compiling caseload data and referring patients to specific mental health officers and physicians in supporting MTFs.
- Providing counseling to soldiers experiencing emotional or social problems.
- Conducting or assisting with group counseling and debriefing sessions and leading group discussions.
- Collecting data in unit survey interviews pertaining to unit cohesion, morale, and individual mental readiness for combat.
- Conducting or assisting in critical event debriefings.

*e. Mental Health Specialists.* There are eight mental health specialists (E-4, MOS 91X10) assigned to the section. These specialists assist the mental health officer and NCOs in gathering social and psychological data to support patient evaluations. Under the supervision of the mental health officer and NCOs, they provide initial screening of patients suffering emotional or social problems. In addition to their duties, they operate and maintain assigned vehicles. Under the supervision of the mental health officer, their specific duties include—

- Serving as team leaders and providing supportive counseling to BF casualties and misconduct stress behavior cases experiencing emotional or social problems.
- Assisting in the evaluation of BF casualties and misconduct stress behaviors.
- Assessing the mental status (level of functioning capacity) of BF casualties and misconduct stress behaviors and their need for professional services.
- Collecting data in unit survey interviews.
- Assisting in critical event debriefings.
- Driving and maintaining team vehicles.

#### **E-11. Combat Stress Control Fitness Section**

The CSC fitness section has 4 psychiatrists, 4 OT officers, 4 psychiatric/mental health nurses, 8 OT NCOs, 8 mental health NCOs, and 12 mental health specialists assigned to the section. Personnel of this section are task-organized to provide NP triage, diagnosis, stabilization, and treatment at restoration or reconditioning centers. Section personnel also deploy to provide mobile consultation and reconstitution support to units in the vicinity and to reinforce the CSC preventive teams. Section personnel may be task-organized with members of the CSC preventive section into CSC elements for specific missions. The section personnel can

augment a deployed CSH to staff a temporary NP ward. This section can divide into four CSC fitness teams. Elements of this section are sometimes task-organized with elements of the CSC preventive section to form task-organized CSC elements which operate restoration or reconditioning centers. At these centers, they provide NP triage, diagnosis, stabilization, treatment, and disposition. Section personnel, as members of task-organized CSC elements or CSC preventive teams, also deploy routinely to provide preventive consultation and reconstitution support to units in the corps area. They reinforce and may reconstitute CSC medical detachment teams in the division support areas.

#### NOTE

The priority role for all CSC personnel is the prevention of BF and other stress-related casualties. This is as true for the CSC fitness section as it is for the CSC preventive section. The section leader position may be held by any of the officers assigned to the section. The company commander will appoint the section leader based on rank, professional qualifications, and experience. This same rationale is used in selecting leaders for the task-organized CSC elements and CSC fitness team.

*a. Psychiatrists.* The psychiatrists (MAJ [two], CPT [two], MC, AOC 60W00) assigned to this section examine patients and provide consultation. These psychiatrists make neuropsychological and medical diagnosis and prescribe and provide treatment. They also direct disposition of patients. The senior psychiatrist assigned to the section performs the duties of section leader and directs the activities of the section when the section is assembled. Psychiatrists assigned to this section may be deployed in support of CSC operations with the section, or as members of either a CSC preventive team or a task-organized CSC element. When deployed as a member of a CSC preventive team or a task-organized CSC element, the psychiatrists' duties include—

- Establishing and providing CSC support.
- Providing staff consultation to supported units as required. This includes nuclear surety, security clearance, and the alcohol and drug abuse preventive programs.
- Being responsible for the diagnosis, treatment, rehabilitation, and disposition of NP and problematic BF cases.
- Participating in the diagnosis and treatment of the wounded, ill, and injured, especially of those who can RTD quickly.
- Consulting and providing training to unit leaders and medical personnel regarding identification and management of NP disorders, BF, and misconduct stress behaviors.
- Providing therapy or referral for soldiers with NP disorders.

- Providing supervision and training of assigned and attached mental health personnel.
- Conducting and supervising unit survey interviews and critical event debriefings.

*b. Occupational Therapy Officers.* Four OT officers (MAJ [two], CPT [two], SP, AOC 65A00) are assigned to the section. They serve as environmental managers using daily living tasks, physical reconditioning, work, and other activities to counteract combat stress reactions. Preventive treatment programs include individual work assignments, organized group work projects, common soldier task review, stress management education, recreation, and physical reconditioning. Their responsibilities include—

- Providing command consultation to leaders regarding work schedules and restorative off-duty activity programs.
- Assessing and advising on ergonomically sound work practices.
- Performing functional occupational evaluations of BF casualties.
- Performing neuromuscular evaluations, especially upper extremities and hands.
- Assigning BF casualties to physical reconditioning and work groups.
- Overseeing physical reconditioning and work programs for BF casualties.
- Selecting appropriate activities based on a BF casualty's assessment.
- Evaluating functional work capacity.
- Modifying reconditioning programs, as required.
- Maintaining records of therapy/treatment.
- Reporting status of BF casualties to psychiatrists and staff members on a daily basis, or in accordance with the TSOPs.
- Conducting unit survey interviews and critical event debriefings.

*c. Psychiatric/Mental Health Nurses.* The four psychiatric/mental health nurses (MAJ [two], AOC 66C7T, and CPT [two], AOC 66C00, AN) provide specialized care, as required. They provide care for all BF, misconduct stress behaviors, and NP casualties, especially those with severe behavioral disturbances and/or concurrent physical illness or injury. They administer medications according to the psychiatrist/physician's orders. The clinical nurse specialists (AOC 66C7T), when properly trained, may prescribe medications under the supervision of a psychiatrist/physician. In coordination with the psychiatrist, clinical psychologist, occupational therapist, and other section members, the psychiatric nurses' responsibilities include—

- Conducting individual and group therapy and stress control education sessions.

## C 1, FM 8-51

- Providing preventive and command consultation, especially to medical units.
- Assisting with the development of the RTD plan for each case.
- Ensuring the BF casualty's therapeutic program, as outlined in the RTD plan, is followed.
- Monitoring the BF casualty's status and recording pertinent case data.
- Conducting nursing reports in accordance with TSOPs to update section members.
- Conducting and supervising unit survey interviews and critical event debriefings.

*d. Occupational Therapy Noncommissioned Officers.* Eight OT NCOs (E-6 [four], MOS 91L30N3, and E-5 [four], MOS 91L20N3) are assigned to the section. They assist the occupational therapists with—

- Evaluating functional capacity and supervising physical reconditioning programs.
- Coordinating and setting up work programs with supported and supporting units and overseeing the work programs.
- Supervising and ensuring appropriate training for subordinate OT specialists and other mental health personnel.
- Providing BF casualty status updates to the occupational therapists and other staff members as required.
- Providing direct supervision of BF casualties and squad leaders.
- Assisting with unit survey interviews and critical event debriefings.
- Assisting with the supervision of work programs.
- Assisting with the identification of useful work projects.
- Assisting with organizing activities which facilitate the recovery of the BF casualties.
- Serving as team leader for up to 12 BF casualties.

*e. Mental Health Noncommissioned Officers.* A total of eight mental health NCOs (E-6 [four], MOS 91X30, and E-5 [four], MOS 91X20) are assigned to the CSC fitness section. They assist in a wide range of psychological and social services.

(1) The NCOs, E-6, are assigned as team chiefs of the CSC fitness teams. Their responsibilities include—

- Collecting and recording social and psychological data.
- Counseling soldiers with personal, behavioral, or psychological problems.
- Assisting with the management of the section.
- Deploying as members of the CSC preventive team or task-organized CSC elements.

Their general duties include—

- Assisting in a wide range of psychological and social services.
- Assisting with initial screening and assessment of new cases.
- Compiling caseload data and referring BF casualties to mental health officers and psychiatrists.
- Providing counseling to BF casualties experiencing emotional or social problems.
- Assisting the psychologist with administration of psychological testing.
- Assisting with group counseling and therapy sessions and leading group discussions.
- Assisting with unit survey interviews and critical event debriefings.

(2) Four mental health NCOs (E-5) manage and provide supervision for BF casualty care. They deploy with either the CSC fitness teams or the task-organized CSC elements to supervise and function as BF casualty care managers for the restoration and reconditioning centers. Other duties and responsibilities include—

- Assisting the psychiatric nurses with planning and executing the establishment, disestablishment, and movement of the reconditioning center.
- Assisting the psychiatric nurses with conducting restoration and reconditioning center operations and with the administration of medications and supervision of subordinates and BF casualties.
- Providing guidance and training to subordinate mental health specialists and other BF care providers.
- Providing direct supervision for BF casualties (when assigned as their squad leader) and monitoring their progress.

*f. Mental Health Specialists.* Twelve mental health specialists (E-4 [eight] and E-3 [four], MOS 91X10) provide BF casualty care and intervention, as required. These mental health specialists deploy with either the CSC fitness teams or the task-organized CSC elements. Their duties include—

## **C 1, FM 8-51**

- Following the RTD plans for cases placed under their supervision.
- Coordinating with the psychiatric nurses and other staff members on questions pertaining to the RTD plan.
- Providing direct supervision for BF casualties (as squad leaders) and monitoring their progress.
- Recording and reporting to the psychiatric nurses and other mental health staff members on the status and any other pertinent observation of cases assigned to them.
- Assisting with unit survey interviews and critical event debriefings.
- Operating and maintaining assigned vehicles.

## **Section IV. COMBAT STRESS CONTROL DETACHMENT**

### **E-12. Medical Detachment, Combat Stress Control (TOE 08567AA00)**

The CSC medical detachment is a 43-person unit composed of a headquarters, a CSC preventive section (composed of a maximum of four CSC preventive teams), and a CSC fitness section (composed of two CSC fitness teams). The modular CSC teams found in the CSC medical detachment are similar to those found in the CSC medical company. The CSC medical detachment provides CSC planning, consultation, training, and staff advice to C2 headquarters and the units to which they are assigned regarding—

- Combat and noncombat stressors affecting the troops.
- Mental readiness.
- Morale and cohesion.
- Potential for BF casualties.

The detachment provides NP triage, basic stabilization, and restoration for BF casualties. Under some circumstances, it may provide reconditioning for NP and alcohol and drug abuse patients. This unit is dependent on support from appropriate elements of the corps to include—

- Religious support.
- Finance support.
- Legal support.



- Personnel and administrative support.
- Laundry and bath services.
- Clothing exchange for unit personnel and stress casualty caseload.
- Communications and operations information support.

The detachment is dependent on units to which it is attached for support, to include—

- Food service.
- Water distribution.
- Medical treatment.
- Logistical support, including combat health logistics.
- Patient administration (assisted by its own enlisted patient administration specialist, MOS 71G10).
- Unit maintenance for the detachment's communications and power generator equipment and vehicle maintenance (assisted by its own light-wheel vehicle mechanic, MOS 63B10).

*a. Mission.* The CSC medical detachment provides complete preventive and treatment services in direct support of the division and corps personnel deployed forward. It also provides CSC support on an area basis to all services and indigenous population as directed in stability operations or support operations which include domestic support operations, humanitarian assistance, disaster relief, and peace support operations. As the tactical situation permits, this detachment can provide all six of the CSC functions identified.

*b. Assignment.* The CSC medical detachment is normally assigned to a corps Medical Brigade (TOE 08432LXX) or a corps MEDCOM (TOE 08611LXX). It may be further attached to a Medical Company, CSC (TOE 08467A000), an ASMB (TOE 08456A000), or a division medical company.

### **E-13. Detachment Headquarters**

The detachment headquarters section provides C2 for the detachment. The headquarters section is responsible for planning, coordinating, and implementing CSC support for supported units. Personnel of the headquarters section provide maintenance, supply and service, and personnel administration support. The detachment headquarters is composed of the following personnel:

- Detachment commander who also works as a treating clinician with the CSC preventive or CSC fitness section.

## C 1, FM 8-51

- Health service administrative assistant.
- Detachment NCOIC.
- Supply sergeant.
- Patient administration specialist.
- Light-wheel vehicle mechanic.
- Personnel administration specialist/unit clerk.
- Cook.

Detachment officers and NCOs from the CSC preventive team and the CSC fitness team may be assigned additional duties which enhance the overall effectiveness of the headquarters section. Additional duty responsibilities may include—

- Maintenance.
- Training.
- Security, plans, and operations.
- Nuclear, biological, and chemical defense.
- Supply.

These duties may be rotated to achieve maximum cross-training.

*a. Detachment Commander.* The detachment commander, a psychiatrist or other clinical officer (LTC, MC/MS/AN/SP, AOC 60W00/73A67/73B67/66CTT/65A00) performs normal C2 and supervisory functions, as well as serving as a treating clinician in one of the CSC preventive or CSC fitness teams. He coordinates with the command surgeon and mental health sections regarding care and disposition of patients. He exercises clinical supervision over treatment in all the CSC teams. He provides NP expertise to supported unit headquarters. In conjunction with supported unit headquarters and MTFs, the detachment commander plans CSC support for the unit's operations. He deploys the detachment teams separately, or task organizes personnel across teams as needed to form task-organized CSC elements. He appoints team leaders based on qualifications by experience as well as by AOCs.

*b. Health Service Administrative Assistant.* The health service administrative assistant, (1LT, MS, AOC 70B67) is the principal assistant to the detachment commander on all matters pertaining to the tactical employment of detachment assets. He is responsible for overseeing operations and administrative, supply, and maintenance activities within the detachment. His responsibilities also include—

- Coordinating administrative activities with the staff of the higher medical headquarters.
- Ensuring unit operations and communications security.
- Keeping the commander current on the corps' and supported divisions' tactical situations.
- Assisting the commander with development of CSC support estimates and plans.
- Planning and scheduling unit training activities.
- Coordinating movement orders and logistical support for deployed detachment elements.

*c. Detachment Noncommissioned Officer in Charge.* The detachment NCOIC (E-7, MOS 91X40) assists the detachment commander in the accomplishment of his duties. He performs administrative duties; he receives and consolidates reports from deployed detachment elements and forwards them to higher headquarters. The detachment NCOIC coordinates support for the detachment and for detachment elements deployed to supported units. He represents the commander at staff meetings and on-site visits to the CSC teams when the commander is occupied with clinical duties. When the detachment is divided into CSC preventive and CSC fitness teams or task-organized CSC elements, the NCOIC normally locates with the CSC fitness team. He supervises the detachment activities of the unit clerk and maintains liaison between the commander and assigned NCOs. He provides guidance to enlisted members of the detachment and represents them to the commander. He plans, coordinates, supervises, and participates in activities pertaining to organization, training, and combat operations for the detachment. He assists the detachment commander in the performance of his duties. The detachment NCOIC also assists the health service administrative officer and performs the duties of an operations NCO.

*d. Supply Sergeant.* The supply sergeant (E-5, MOS 92Y20) requests, receives, inspects, stores, safeguards, and issues general supplies. He operates unit-level computers. The supply sergeant prepares all unit/organizational supply documents. He maintains the detachment supply records, supervises unit supply operations, and maintains accountability for all equipment organic to the detachment. He maintains and receives small arms and controls weapons and ammunitions in security areas. The supply sergeant is responsible for scheduling and performing preventive- and organizational-level maintenance on weapons. The supply sergeant reviews the Unit Material Condition Status Report and annotates changes. He posts transactions to organizational and installation property books and supporting transaction files. He determines methods of obtaining relief from responsibility for lost, damaged, and destroyed supply items. The supply sergeant is responsible for coordinating all supply activities.

*e. Patient Administration Specialist.* The patient administration specialist (E-4, MOS 71G10) is responsible for managing patient statistics of all BF casualties seen by the detachment element. His duties are consistent with those identified above (paragraph E-9m).

*f. Light-Wheeled Vehicle Mechanic.* The light-wheeled vehicle mechanic (E-4, MOS 63B10) performs organizational maintenance. His duties are consistent with those identified above (paragraph E-9n).

**NOTE**

When the light-wheeled vehicle mechanic deploys, he works with the maintenance section/element of the unit to which the task-organized CSC element is attached.

*g. Personnel Administrative Specialist/Unit Clerk.* The unit clerk (E4, MOS 75B10) provides and coordinates personnel and administrative support to company personnel and maintains unit administrative records. His duties are consistent with those identified above in paragraph E-9j.

*h. Cook.* One cook (E3, MOS 92G10) provides food service (tray-pack heating) for the detachment when it is assembled. More often, he is deployed with a task-organized CSC element and further attached for work with the food service section of the supported medical unit. He also trains CSC personnel on food tasks which may be used as a part of their CSC restoration or reconditioning program. He may serve as work group leader for BF casualties performing food service tasks as part of the BF casualty's treatment.

**E-14. Preventive Section**

This section has four clinical psychologists, four social work officers, four mental health NCOs, and four mental health specialists. This section can divide into four 4-person CSC preventive teams. Three CSC preventive teams are normally allocated, one each, to the supported division's maneuver brigades. The fourth CSC preventive may provide moving support to the aviation brigade, attached brigade-sized units, corps units in the division AO, or an ASMC in the corps area. When applicable, it combines with a CSC fitness team to staff the reconditioning program for the supported division and corps units, usually collocated with a CSH. Combat stress control preventive team leaders are selected by the detachment commander based on experience as well as on grade and specialty. Elements of the section may also be task-organized with elements of the CSC fitness team to form task-organized CSC elements for special CSC operations. The CSC preventive section's responsibilities include—

- Preventing stress, misconduct stress behaviors, and post-traumatic casualties by providing—
  - Command consultation.
  - Stress prevention education.
  - Debriefings (critical events and after action).
  - Staff planning.
  - Case evaluation and triage.
  - Counseling intervention at supported units.

- Preventive consultation support to leaders, chaplains, and medical personnel.
- Assisting nonmedical units with REST category BF casualties and the RTD of recovered BF soldiers.
- Providing NP triage and stabilization.
- Supervising restoration of HOLD category BF casualties by medical personnel and providing restoration for selected cases.
- Deploying to units to provide reconstitution support.

*a. Clinical Psychologists.* There are four clinical psychologists (MAJ [two], CPT [two], MS, AOC 73B67) assigned to the section. Their duties include—

- Providing diagnostic expertise for triage.
- Conducting psychological and neuropsychological testing.
- Providing behavioral treatment and counseling.
- Conducting and supervising surveys of unit cohesion, morale, and individual mental readiness for combat.
- Providing command consultation.
- Supervising subordinate personnel.
- Conducting and supervising critical event debriefings.

*b. Social Work Officers.* Four social work officers (MAJ [two], CPT [two], MS, AOC 73A67) are assigned to this section. These social work officers provide proactive consultation and evaluate psychosocial functioning and mission context of the supported units. They give individual and group counseling and debriefings, supervise restoration/reconditioning, and coordinate RTD of recovered cases. They provide staff advice and coordinate social services agency support. As a member of a CSC preventive team or other CSC element, in addition to those duties identified above (paragraph E-10*b*), the social work officers' duties include—

- Evaluating soldiers with BF and misconduct stress behavior.
- Supervising subordinate personnel.

*c. Mental Health Noncommissioned Officers.* There are four mental health NCOs (E-5, MOS 91X20). One of these NCOs acts as the section sergeant and the other three NCOs act as assistant section sergeants and assist the section sergeant with his duties. Their duties are consistent with those identified

## C 1, FM 8-51

above (paragraph E-10*d*). They deploy as NCOICs of teams and may be assigned as the team leader for up to 14 BF casualties in a restoration center. As stated above, the senior mental health NCO (E-5) also performs as the preventive section sergeant. His duties are the same as those previously identified above (paragraph E-11*e*).

*d. Mental Health Specialists.* There are four mental health specialists (E-4, MOS 91X20) assigned to the section. These specialists perform those duties previously identified above (paragraph E-10*e*). In addition to their duties, they operate and maintain assigned vehicles.

### E-15. Combat Stress Control Fitness Section

This section has two psychiatrists, two OT officers, two psychiatric/mental health nurses, four OT NCOs, four mental health NCOs, and six mental health specialists. The detachment NCOIC (E-7, MOS 91X40) is located with the CSC fitness section and serves as the senior mental health NCO. The section can divide into two CSC fitness teams. One team usually collocates with the supported division's MSMC to provide mobile CSC support to the DSA and conduct restoration programs, as required. The second CSC fitness team augments area support to corps units in the division AO and in forward areas of the corps. It can conduct the corps-level reconditioning program for the supported division and corps units and usually collocates with a CSH. The CSC fitness team provides staff and equipment for operating a restoration or reconditioning center. Personnel of this section are task-organized to provide NP triage, diagnosis, stabilization, and treatment at a restoration or reconditioning center. Section personnel also deploy to provide mobile consultation and reconstitution support to units in the vicinity and to reinforce the CSC preventive teams of the detachment. Section personnel may be task-organized with members of the CSC preventive section into CSC elements for specific missions. The section personnel can augment a deployed hospital to staff a temporary NP ward. The section (and team) leader's position may be held by any of the officers assigned to the section. The commander will base his selection on experience as well as specialty and grade. The commander, because of his other duties, normally appoints one of the officers assigned to the section as the section leader.

*a. Psychiatrists.* The psychiatrists (LTC [one], MAJ [one], MC, AOC 60W00) assigned to this section examine patients and provide consultation. These psychiatrists make neuropsychological and medical diagnosis and prescribe and provide treatment. They also direct disposition of patients. The senior psychiatrist directs the activities of the section when the section is assembled. Psychiatrists assigned to this section may be deployed in support of CSC operations with the section, or as members of either a CSC fitness team or a task-organized CSC element. When employed as a member of a CSC fitness team or a task-organized CSC element, the psychiatrists' duties include—

- Establishing and providing CSC support.
- Providing staff consultation to supported units as required. This includes nuclear surety, security clearance, and alcohol and drug abuse preventive programs.
- Being responsible for the diagnosis, treatment, rehabilitation, and disposition of NP and problematic BF cases.

- Participating in the diagnosis and treatment of the wounded, ill, and injured, especially of those who can RTD quickly.

- Consulting and providing training to unit leaders and medical personnel regarding identification and management of NP disorders, BF, and misconduct stress behaviors.

- Providing therapy or referral for soldiers with NP disorders.

- Providing supervision and training of assigned and attached mental health personnel.

- Conducting and supervising unit survey interviews and critical event debriefings.

*b. Occupational Therapy Officers.* The OT officers (MAJ [one] and CPT [one], SP, AOC 65A00) perform those duties previously identified above (paragraph E-11*b*).

*c. Psychiatric/Mental Health Nurses.* The psychiatric/mental health nurses (MAJ [one] and CPT [one], AN, AOC 66C00) provide specialized nursing care and management of BF casualties. The position should be filled by clinical nurse specialists (AOC 66C7T). The duties of the psychiatric/mental health nurses are consistent with those previously identified above (paragraph E-11*c*).

*d. Senior Mental Health Noncommissioned Officer.* The senior mental health NCO (E-7, MOS 91X40) is also the detachment NCOIC. He assists the CSC fitness section leader with the accomplishment of his duties. He provides assistance with the management of technical and tactical operations of the section. His specific duties include—

- Keeping the section leader informed.

- Monitoring, facilitating, and supervising the training activities of subordinates.

- Monitoring and coordinating situation reports from deployed CSC preventive teams.

- Conducting classes on selected mental health topics for senior NCOs of supported units.

*e. Occupational Therapy Noncommissioned Officers.* Four OT NCOs (E-6 [two], MOS 91L30N3, and E-5 [two], MOS 91L20N3) are assigned to the section. The OT NCOs deploy with either CSC fitness teams or task-organized CSC elements. Their duties are consistent with those listed above (paragraph E-11*d*).

*f. Mental Health Noncommissioned Officers.* A total of four mental health NCOs (E-6 [two], MOS 91X30, and E-5 [two], MOS 91X20) are assigned to CSC fitness section. They assist in a wide range of psychological and social services.

(1) The NCOs, E-6, are assigned as team chiefs of the CSC fitness teams. A team chief deploys with each CSC fitness team to supervise and function as the BF casualty care manager for a restoration center. The team chief assists with establishment, disestablishment, and movement of the team.

## C 1, FM 8-51

He also assists with conducting restoration and reconditioning center operations. The team chief may provide direct supervision for up to 12 BF casualties when assigned as their squad leader. The team chief may be deployed temporarily to reinforce a CSC preventive team. The responsibilities of the team chief include—

- Collecting and recording social and psychological data.
- Counseling soldiers with personal, behavioral, or psychological problems.
- Assisting with the management of the section.
- Deploying as members of CSC preventive team or task-organized CSC elements.

Their general duties include—

- Assisting in a wide range of psychological and social services.
- Assisting with initial screening and assessment of new cases.
- Compiling caseload data and referring BF casualties to specific mental health officers and psychiatrists.
- Providing counseling to BF casualties experiencing emotional or social problems.
- Assisting the psychologist with administration of psychological testing.
- Assisting with group counseling and therapy sessions and leading group discussions.
- Assisting with unit survey interviews and critical event debriefings.

(2) The two mental health NCOs (E-5) manage and provide supervision for BF casualty care. They deploy with either CSC fitness teams or task-organized CSC elements to supervise and function as BF casualty care managers for the restoration and reconditioning centers. Other duties and responsibilities include—

- Assisting the psychiatric nurses with planning and executing the establishment, disestablishment, and movement of the reconditioning center.
- Assisting the psychiatric nurses with conducting restoration and reconditioning center operations and with the administration of medications and supervision of subordinates and BF casualties.
- Providing guidance and training to subordinate mental health specialists and other BF care providers.
- Providing direct supervision for BF (when assigned as their squad leader) casualties and monitoring their progress.



*g. Mental Health Specialists.* Six mental health specialists (E-4 [four] and E-3 [two], MOS 91X10) provide BF casualty care and intervention, as required. These mental health specialists deploy with either the CSC fitness teams or task-organized CSC elements. In addition to their duties, they operate and maintain their assigned vehicle. Duties for the mental health specialist include—

- Following the RTD plans for cases placed under their supervision.
- Coordinating with the psychiatric nurses and other staff members on questions pertaining to the RTD plan.
- Providing direct supervision for BF casualties (as squad leaders) and monitoring their progress.
- Recording and reporting to the psychiatric nurses and other mental health staff members on the status and any other pertinent observation of cases assigned to them.
- Assisting with unit survey interviews and critical event debriefings.
- Operating and maintaining assigned vehicles.

## GLOSSARY

## ABBREVIATIONS, ACRONYMS, AND DEFINITIONS

**AAR** after-action review

**ABCA** American, British, Canadian, and Australian

**ACR** armored cavalry regiment

**ADAPCP** Alcohol and Drug Abuse Prevention and Control Program

**advanced trauma management** This is the resuscitative and stabilizing medical or surgical treatment provided to patients to save life or limb and to prepare them for further evacuation without jeopardizing their well-being or prolonging the state of their condition.

**AG** adjutant general

**ambulance exchange point (AXP)** A point in an ambulance shuttle system where a patient is transferred from one ambulance to another en route to a medical treatment facility.

**AMEDDC&S** Army Medical Department Center and School

**AN** Army Nurse Corps

**AO** See area of operations.

**AOC** area of concentration

**AR** Army regulation

**area of operations (AO)** That portion of an area of conflict necessary for military operations. Areas of operations are geographical areas assigned to commanders for which they have responsibility and in which they have authority to conduct military operations.

**ASMB** area support medical battalion

**ASMC** area support medical company

**assign** To place units or personnel in an organization where such placement is relatively permanent, and/or where such organization controls, administers, and provides logistical support to units of personnel for the primary function or a greater portion of the functions of the unit or personnel. (See *also* attach; operational command; operational control; organic.)

**attach** The temporary placement of units or personnel in an organization. Subject to limitations imposed by the attachment order, the commander of the formation, unit, or organization receiving the attachment will exercise the same degree of command and control as he does over units and personnel organic to his command. However, the responsibility for transfer and promotion of personnel will normally be retained by the parent formation, unit, or organization. (See *also* assign; operational command; operational control; organic.)

**AWOL** absent without leave

**AXP** See ambulance exchange point.

**BAS** battalion aid station

**battle fatigue (BF)** Also referred to as combat stress reaction or combat fatigue. Fatigue by definition is the distress and impaired performance that comes from doing something (anything) too hard and/or too long. The term *battle fatigue* is applied to any combat stress reaction which is treated the way all fatigue is treated, with the four "Rs"--Reassure of normality, Rest (respite from the work), Restoration of confidence through talk and activities, and Replenish of nutrition, and hydration, hygiene and a sense of physical well-being.

**BF** See battle fatigue.

**brigade support area (BSA)** A designated area in which combat service support elements from division support command and corps support command provide logistics support to a brigade. The brigade support area normally is located 20 to 25 kilometers behind the forward edge of the battle area.

**BSA** See brigade support area.

**C2** See command and control.

**camouflage** The use of concealment and disguise to minimize detection or identification of troops, weapons, equipment, and installations. It includes taking advantage of the immediate environment as well as using natural and artificial materials.

**casualty** Any person who is lost to his organization by reason of having been declared dead, wounded, injured, diseased, interned, captured, retained, missing in action, beleaguered, besieged, or detained.

**CH** chaplain

**CHS** See combat health support.

**clearing station** An operating field medical facility established by a clearing company or medical company which provides emergency or resuscitative treatment for patients until evacuated and definitive treatment for patients with minor illness, wounds, or injuries.

**combat health support (CHS)** This term is used in current doctrine to include all services performed, provided, or arranged by the Army Medical Department to promote, improve, conserve, or restore the mental and/or physical well-being of personnel in the Army and, as directed, in other services, agencies, and organizations.

**combat neuropsychiatric triage** Is the process of sorting combat stress-related casualties and neuropsychiatric patients into categories based on how far forward they can be treated. In operations other than war, this may be referred to as proximate neuropsychiatric triage.

**combat service support (CSS)** The support provided to sustain combat forces, primarily in the fields of administration and logistics. It may include administrative services, chaplain service, civil affairs, food service, finance, legal service, maintenance, medical service, military police, supply, transportation, and other logistical services. The basic mission of combat service support is to develop and maintain maximum combat power through the support of weapons systems.

**combat stress control (CSC)** A coordinated program for the prevention, triage and treatment of each echelon of battle fatigue to maximize rapid return to duty and minimize misconduct stress reactions and post-traumatic stress disorders. This program is conducted by unit mental health personnel plus echelon above division combat stress control units.

**combat support (CS)** Fire support and operational assistance provided to combat elements. May include artillery, air defense, aviation (less air cavalry and attack helicopter), engineer, military police, signal, and electronic warfare.

**combat trains** The portion of unit trains that provides the combat service support required for immediate response to the needs of forward tactical elements. At company level, medical recovery and maintenance elements normally constitute the combat trains. At battalion, the combat trains normally consist of ammunition and POL vehicles, maintenance/recovery vehicles, and crew and the battalion aid station. (See also field trains; unit trains.)

**combat zone (CZ)** That area required by combat forces for the conduct of operations. It is the territory forward of the Army rear area boundary.

**command and control (C2)** The exercise of command that is the process through which the activities of military forces are directed, coordinated, and controlled to accomplish the mission. This process encompasses the personnel, equipment, communications, facilities, and procedures necessary to gather and analyze information, to plan for what is to be done, and to supervise the execution of operations.

**command post (CP)** The principal facility employed by the commander to command and control combat operations. A command post consists of those coordinating and special staff activities and representatives from supporting Army elements and other services that may be necessary to carry out operations. Corps and division headquarters are particularly adaptable to organization by echelon into a tactical command post, a main command post, and a rear command post.

**commander's estimate** The procedure whereby a commander decides how to best accomplish the assigned mission. It is a thorough consideration of the mission, enemy, terrain, troops available, time, weather, and other relevant factors. The commander's estimate is based on personal knowledge of the situation and on staff estimates.

**communications security** The protection resulting from all measures designed to deny unauthorized persons information of value that might be derived from the possession and study of telecommunications, or to mislead unauthorized persons in their interpretation of the results of such possession and study. Includes cryptosecurity, transmission

security, emission security, and physical security of communications security materials and information.

**communications zone (COMMZ)** That rear area of the theater of operations, behind but contiguous to the combat zone, that contains the lines of communication, establishment for supply and evacuation, and other agencies required for the immediate support and maintenance of the field forces.

**COMMZ** *See* communications zone.

**concealment** The protection from observation.

**concept of operations** A graphic, verbal, or written statement in broad outline that gives an overall picture of a commander's assumption or intent in regard to an operation or a series of operations; includes, at a minimum, the scheme of maneuver and the fire support plan. The concept of operations is embodied in campaign plans and operation plans, particularly when the plans cover a series of connected operations to be carried out simultaneously or in secession. It is described in sufficient detail for the staff and subordinate commanders to understand what they are to do and how to fight the battle without further instructions.

**CONUS** continental United States

**CP** *See* command post.

**CPT** captain

**CRC** combat reconditioning center

**CS** *See* combat support.

★**CSA** corps support area

**CSC** *See* combat stress control.

**CSH** combat support hospital

**CSS** *See* combat service support.

**CTA** common table of allowances

**CZ** *See* combat zone.

**DA** Department of the Army

**DA PAM** Department of the Army pamphlet

**DD/DOD** Department of Defense

**DEPMEDS** Deployable Medical Systems

**direct support** (1) A mission requiring a force to support another specific force and authorizing it to answer directly the supported force's request for assistance. (2) In the North Atlantic Treaty Organization, the support provided by a unit or formation not attached to, nor under command of, the supported unit or formation, but required to give priority to the support required by that unit or formation. (*See also* general support.)

**DISCOM** division support command

**displace** To leave one position and take another. Forces may be displaced laterally to concentrate combat power in threatened areas. When a unit is advancing, its command post must displace forward.

**division support area (DSA)** An area normally located in the division rear, positioned near air landing facilities and along the main supply route. The division support area contains the division support command, command post, the headquarters element of the division support command battalions, and those division support command elements charged with providing backup support to combat service support elements in the brigade

support area and direct support to units located in the division rear. Selected corps support command elements may be located in the division support area to provide direct support backup and general support as required.

**DMOC** division medical operations center

**DNBI** disease and nonbattle injuries

★**DOD/DD** Department of Defense

**DPCA** Deputy for Personnel and Civilian Affairs

**DSA** *See* division support area.

**DSM III-R** *Diagnostic and Statistical Manual of Mental Disorders*, Third Edition, Revised

**Echelon I** (Unit level) First medical care a soldier receives is provided at this level. This care includes immediate lifesaving measures, advanced trauma management, disease prevention, combat stress control prevention, casualty collection, and evacuation from supported units to supporting medical treatment. Echelon I elements are located throughout the combat and communications zones. These elements include the combat lifesavers, combat medics, and battalion aid station. Some or all of these elements are found in maneuver, combat support, and combat service support units. When Echelon I is not present in a unit, this support is provided to that unit by Echelon II medical units.

**Echelon II** Duplicates Echelon I medical care and expands services available by adding dental, laboratory, x-ray, and patient-holding capability. Emergency care, advanced trauma management, including beginning resuscitation procedures, is continued. No general anesthesia is available; if necessary, additional

emergency measures dictated by the immediate needs are performed. Echelon II units are located in the combat zone brigade support area, the corps support area, and the communications zone. Echelon II medical support may be provided by a clearing station; forward support medical company; medical company, forward support battalion; medical company, main support battalion; area support medical companies located in the corps area and in the communications zone.

**Echelon III** This echelon of support expands the support provided at Echelon II. Casualties who are unable to tolerate and survive movement over long distances will receive surgical care in hospitals as close to the division rear boundary as the tactical situation will allow. Surgical care may be provided within the division area under certain operational conditions. Echelon III characterizes the care that is provided by units such as mobile army surgical hospitals and combat support hospitals. Operational conditions may require Echelon III units to locate in offshore support facilities, Third Country support base, or in the communications zone.

**Echelon IV** This echelon of care is provided in a general hospital and field hospital and in other communications zone-level facilities which are staffed and equipped for general and specialized medical and surgical treatment. The field hospital normally operates in the communications zone but may be deployed to the rear boundaries of the corps, if necessary. This echelon of care provides further treatment to stabilize those patients requiring evacuation to continental United States. This echelon also provides area health service support to soldiers within the communications zone.

**Echelon V** In this echelon of care, the casualty is treated in continental United States-based

hospitals, staffed and equipped for the most definitive care available within the health service support system. Hospitals in the continental United States base represent the final level of CHS.

**echelon above corps** Army headquarters and organizations that provide the interface between the theater commander (joint or combined) and the corps for operational matters, and between the continental United States/host nation and the deployed corps for combat service support. Operational echelons above corps may be United States only or allied headquarters, while echelons above corps for combat service support will normally be United States national organizations.

**echelon of care** This is a North Atlantic Treaty Organization term which can be used interchangeably with the term level of care.

**echeloned displacement** Movement of a unit from one position to another without discontinuing performance of its primary function. Normally, the unit divides into two functional elements (base and advance); while the base continues to operate, the advance element displaces to a new site where, after it becomes operational, it is joined by the base element.

**echelonment** An arrangement of personnel and equipment into assault, combat follow up, and rear components or group.

**emergency medical treatment** The immediate application of medical procedures to the wounded, injured, or sick by specially trained medical personnel.

**EPW** enemy prisoner(s) of war

**evacuation** (1) A combat service support function which involves the movement of recovered materiel from a main supply route,

## C 1, FM 8-51

maintenance activity collecting point, and maintenance activity to higher levels of maintenance. (2) The process of moving any person who is wounded, injured, or ill to and/or between medical treatment facilities while providing en route medical care.

**evacuation policy** A command decision indicating the length in days of the maximum period of noneffectiveness that patients may be held within the command for treatment. Patients who, in the opinion of an officiating medical officer, cannot be returned to duty status within the period prescribed are evacuated by the first available means, provided the travel involved will not aggravate their disabilities.

**F** Fahrenheit

**FH** field hospital

**field trains** The combat service support portion of a unit at company and battalion levels that is not required for immediate support of combat elements. At company level, supply and mess teams normally are located in the field trains. A battalion's field trains may include mess teams, a portion of the supply section of the support platoon, and a maintenance element, as well as additional ammunition and POL. Positioning field trains is dependent on such factors as the type of friendly operations underway and available activity in the area. (*See also* combat trains; unit trains.)

**FLOT** *See* forward line of own troops.

**FM** field manual

**FMC** US Field Medical Card, DD Form 1380

**forward line of own troops (FLOT)** A line that indicates the most forward position of friendly forces in any kind of military operation at a specific time. The forward line of own troops

may be at, beyond, or short of the forward edge of the battle area, depicting the nonlinear battlefield.

**fragmentary order** An abbreviated form of an operation order used to make changes in mission to units and to inform them of changes in the tactical situation.

**FSB** forward support battalion

**FSMC** forward support medical company

**FTX** field training exercise

**G1** Assistant Chief of Staff (Personnel)

**G2** Assistant Chief of Staff (Intelligence)

**G3** Assistant Chief of Staff (Operations and Plans)

**G4** Assistant Chief of Staff (Logistics)

**G5** Assistant Chief of Staff (Civil Affairs)

**GC** Geneva Convention Relative to the Protection of Civilian Persons in Time of War, 12 August 1949

**general support** Support that is given to the supported force as a whole and not to any particular subdivision thereof.

**GH** general hospital

**GP** general purpose

**GPW** Geneva Convention Relative to the Treatment of Prisoners of War, 12 August 1949

**GTA** graphic training aid

**GWS** Geneva Convention for the Amelioration of the Condition of Wounded and Sick in Armed Forces in the Field, 12 August 1949

- GWS (Sea)** Geneva Convention for the Amelioration of the Condition of Wounded, Sick, and Shipwrecked Members of Armed Forces at Sea, 12 August 1949
- HHC** headquarters and headquarters company
- HHD** headquarters and headquarters detachment
- host nation** A nation in whose territory the United States or allied forces are operating or supporting the battle.
- host-nation support** Civil and military assistance rendered in peacetime and wartime to allied forces and organizations located in the host nation's territory. The bases of such assistance are commitments arising from national agreements concluded among host nation(s), international organizations, and nation(s) having forces operating in the host nation's territory.
- HSC** headquarters and support company
- IG** inspector general
- JAG** judge advocate general
- KIA** killed in action
- LBE** load bearing equipment
- ★LT** lieutenant
- LTC** lieutenant colonel
- MAJ** major
- MASH** mobile army surgical hospital
- MC** Medical Corps
- MCW** minimal care ward
- MEDCOM** medical command
- MEDDAC** medical department activity
- medical equipment set(s)** Chest(s) containing medical instruments and supplies designed for specific table(s) of organization and equipment units or missions.
- medical intelligence** That intelligence produced from the collecting, evaluation, and analysis of information concerning the medical aspects of foreign areas which have immediate or potential impact on policies, plans, and operations.
- medical treatment facility (MTF)** Any facility established for the purpose of providing medical treatment. This includes aid stations, clearing stations, dispensaries, clinics, and hospitals.
- METT-T** mission, enemy, terrain, troops, and time available
- ★MF2K** Medical Force 2000
- mg** milligram
- MIA** missing in action
- mobility** The percentage of organic equipment and personnel that can be moved in a single lift using organic vehicles. It does not include patients in the medical treatment facility.
- MOPP** mission-oriented protective posture
- MOS** military occupational specialty
- MP** military police
- MRE** meal(s), ready to eat
- ★MRI** Medical Reengineering Initiative
- MS** Medical Service Corps



## C 1, FM 8-51

**MSB** main support battalion

**MSMC** main support medical company

**MSR** main supply route

**MTF** *See* medical treatment facility.

**NBC** nuclear, biological, and chemical

**NCO** noncommissioned officer

**NCOIC** noncommissioned officer in charge

**NP** neuropsychiatric

**NYDN** not yet diagnosed “nervous”

**OPCON** *See* operational control.

**operation order (OPORD)** A directive issued by a commander to subordinate commanders for effecting the coordinated execution of an operation, including tactical movement orders. (*See also* operation plan.)

**operation plan (OPLAN)** A plan for a military operation. It covers a single operation or series of connected operations to be carried out simultaneously or in succession. It implements operations derived from the campaign plan. When the time and/or conditions under which the plan is to be placed in effect occur, the plan becomes an operations order. (*See also* operation order.)

**operational command** North Atlantic Treaty Organization: The authority granted to a commander to assign missions or tasks to subordinate commanders, to deploy units, to reassign forces, and to retain or delegate operational and/or tactical control as may be deemed necessary. It does not of itself include responsibility for administration or logistics. May also be used to denote the

forces assigned to a commander. Department of Defense: The term is synonymous with operational control exercised by the commanders of unified and specified commands over assigned forces in accordance with the National Security Act of 1947, as amended and revised (10 United States Code 124). (*See also* operational control.)

**operational control (OPCON)** The authority delegated to a commander to direct forces assigned so that the commander may accomplish specific missions or tasks that are usually limited by function, time, or location; to deploy units concerned; and to retain or assign tactical control to those units. It does not of itself include administrative or logistics control. In the North Atlantic Treaty Organization, it does not include authority to assign separate employment of components of the units concerned. (*See also* assign; attach; operational command.)

**operations security** All measures taken to maintain security and achieve tactical surprise. It includes countersurveillance, physical security, signal security, and information security. It also involves the identification and elimination or control of indicators which can be exploited by hostile intelligence organizations.

**OPLAN** *See* operation plan.

**OPORD** *See* operation order.

**order** A communication written, oral, or by signal that conveys instructions from a superior to a subordinate. In a broad sense, the term *order* and *command* are synonymous. However, an order implies discretion as to the details of execution, whereas a command does not.

**organic** Assigned to and forming an essential part of a military organization; an element

- normally shown in the unit's table of organization and equipment. (*See also* assign; attach; operational control.)
- OT** occupational therapy
- patient** A sick, injured, or wounded person who receives medical care or treatment from medically trained (MOS-or AOC-specific) personnel.
- PCP** phencyclidine hydrochloride
- PIES** proximity, immediacy, expectancy, and simplicity
- PLL** prescribed load list
- PMCS** preventive maintenance checks and services
- POC** point of contact
- PW/POW** prisoner(s) of war
- PROFIS** professional officer filler system
- PVNTMED** preventive medicine
- QSTAG** Quadripartite Standardization Agreement
- ★RCS** requirement control symbol
- rear area** The area in the rear of the combat and forward areas. Combat echelons from the brigade through the field Army normally designate a rear area. For any particular command, that area extending rearward from the rear boundary of their next subordinate formations, or units deployed in the main battle or defense area to their own rear boundary. It is here that reserve forces of the echelon are normally located. In addition, combat support and combat service support units and activities locate in this area. (*See also* brigade support area; division support area.)
- reconstitution** The total process of keeping the force supplied with various supply classes, services, replacement personnel, and equipment required. This process maintains the desired level of combat effectiveness and restores units that are not combat effective to the desired level through the replacement of critical equipment and personnel. Reconstitution encompasses unit regeneration and sustaining support.
- RTD** return to duty
- S1** Adjutant (US Army)
- S2** Intelligence Officer (US Army)
- S3** Operations and Training Officer (US Army)
- S4** Supply Officer (US Army)
- SOI** signal operation instructions
- SP** Army Medical Specialist Corps
- TEMPER** tent, extendable, modular, personnel
- theater of operations (TO)** That portion of an area of conflict necessary for the conduct of military operations, either offensive or defensive, to include administration and logistical support.
- TM** technical manual
- TMDE** test, measurement, and diagnostic equipment
- TO** *See* theater of operations.
- TOC** tactical operations center
- TOE** table(s) of organization and equipment
- TSOP** tactical standing operating procedure

**C 1, FM 8-51**

**TTP** tactics, techniques, and procedures

**UCMJ** Uniform Code of Military Justice

**unit trains** Combat service support personnel and equipment organic or attached to a force that provides supply, evacuation, and maintenance services. Unit trains, whether or not echeloned, are under unit control and no portion of them is released to the control of a higher headquarters. Trains are normally echeloned into combat and field trains. (*See also* combat trains; field trains.)

**US** United States

**warning order** A preliminary notice of an action or order that is to follow. Usually issued as a brief, oral, or written message designed to give subordinates time to make necessary plans and preparations.

**WIA** wounded in action

**WWI** World War I

**WWII** World War II

## REFERENCES

## SOURCES USED

These are the sources quoted or paraphrased in this publication.

## ABCA QSTAG

909. *Principles of Prevention and Management of Combat Stress Reaction, Edition 1.* 25 October 1991.

## Army Publications

- AR 40-501. *Standards of Medical Fitness.* 1 July 1987. (Reprinted with basic including C1.)
- AR 310-25. *Dictionary of United States Army Terms (Short Title: AD).* 15 October 1983. (Reprinted with basic including C1.)
- AR 570-2. *Manpower Requirements Criteria.* 15 May 1992.
- AR 340-21. *The Army Privacy Program.* 5 July 1985.
- DA Pam 600-69. *Unit Climate Profile, Commanders Handbook.* 1 October 1986.
- FM 8-10-4. *Medical Platoon Leaders' Handbook—Tactics, Techniques, and Procedures.* 16 November 1990.
- FM 8-10-24. *Area Support Medical Battalion—Tactics, Techniques, and Procedures.* 13 October 1993.
- FM 63-20. *Forward Support Battalion.* 26 February 1990.
- FM 63-21. *Main Support Battalion.* 7 August 1990.
- FM 100-9. *Reconstitution.* 13 January 1992.
- FM 100-10. *Combat Service Support.* 18 February 1988.
- FM 101-5-1. *Operational Terms and Symbols.* 21 October 1985.
- GTA 21-3-4. *Battle Fatigue, Normal, Common Signs, What to do for Self and Buddy.* June 1986.

\*This source was also used to develop this publication.

## DOCUMENTS NEEDED

These documents must be available to the intended users of this publication.

- \*AR 40-66. *Medical Records and Quality Assurance Administration.* 31 January 1985. (Reprinted with basic including C1.)
- \*AR 40-216. *Neuropsychiatric and Mental Health.* 10 August 1984.
- \*AR 40-400. *Patient Administration.* 1 October 1983.
- \*AR 635-200. *Enlisted Personnel.* July 1984. (Reprinted with basic including C1-14.)
- \*DA Pam 27-1. *Treaties Governing Land Warfare.* 7 December 1956.
- \*FM 8-10. *Health Service Support in a Theater of Operations.* 1 March 1991.
- ★\*FM 8-10-1. *The Medical Company—Tactics, Techniques, and Procedures.* 29 December 1994.
- \*FM 8-10-3. *Division Medical Operations Center—Tactics, Techniques, and Procedures.* 1 March 1991.
- \*FM 8-10-5. *Brigade and Division Surgeons' Handbook—Tactics, Techniques, and Procedures.* 10 June 1991.
- \*FM 8-10-6. *Medical Evacuation in a Theater of Operations—Tactics, Techniques, and Procedures.* 31 October 1991.
- \*FM 8-10-8. *Medical Intelligence in a Theater of Operations.* 7 July 1989.
- \*FM 8-42. *Medical Operations in Low Intensity Conflict.* 4 December 1990.
- \*FM 8-50. *Prevention and Medical Management of Laser Injuries.* 8 August 1990.
- \*FM 8-55. *Planning for Health Service Support.* 15 February 1985.
- \*FM 8-230. *Medical Specialist.* 24 August 1984.
- \*FM 21-10. *Field Hygiene and Sanitation.* 22 November 1988.
- \*FM 22-51. *Leaders' Manual for Combat Stress Control.* (To be published.)
- \*FM 27-10. *The Law of Land Warfare.* 18 July 1956. (Change 1, July 1976.)

## C 1, FM 8-51

- \*FM 63-21. *Main Support Battalion*. 7 August 1990.
- \*FM 100-5. *Operations*. 14 June 1993.
- DA Form 1155. *Witness Statement on Individual*. 1 June 1966.
- DA Form 1156. *Casualty Feeder Report*. 1 June 1966.
- DA Form 2404. *Equipment Inspection and Maintenance Worksheet*. 1 April 1989.
- DA Form 2405. *Maintenance Request Register*. 1 April 1962.
- DA Form 2407. *Maintenance Request*. August 1988.
- DA Form 2408-9. *Equipment Control Record*. 1 October 1972.
- DA Form 2409. *Equipment Maintenance Log (Consolidated)*. 1 April 1992.
- DD Form 2A. *US Armed Forces Identification Card*. 1 July 1974.
- DD Form 314. *Preventive Maintenance Schedule and Record*. December 1953.
- DD Form 1265. *Request for Convoy Clearance*. 1 January 1959.
- DD Form 1380. *US Field Medical Card*. (Books consisting of 20 two-part sets.) 1 June 1962.
- DD Form 1934. *Geneva Convention Identity Card for Medical and Religious Personnel Who Serve In or Accompany the Armed Forces*. July 1974.
- DD Form 2163. *Medical Equipment Verification/Certification*. 1 November 1978.

### READINGS RECOMMENDED

These readings contain relevant supplemental information.

#### Joint and Multiservice Publications

- AR 40-350. *Medical Regulating To and Within the Continental United States*. BUMEDINST 6320.1D; AFR 168-11; BMS CIR 75-15; CGCOMDTINST 6320.8A. 30 March 1990.

#### References-2

- AR 40-535. *Worldwide Aeromedical Evacuation*. AFR 164-5; OPNAVINST 4630.9C; MCO P4630.9A. 1 December 1975. (Reprinted with basic including C1.)
- AR 40-538. *Property Management During Patient Evacuation*. BUMEDINST 6700.2B; AFR 167-5. 1 June 1980.
- AR 40-562. *Immunizations and Chemoprophylaxis*. NAVMEDCOMINST 6230.3; AFR 161-13; CGCOMDTINST 6230.4D. 7 October 1988.
- FM 8-8. *Medical Support in Joint Operations*. NAVMED P-5047/AFM 160-20. 1 June 1972. (Reprinted with basic including C1.)
- FM 8-9. *NATO Handbook on the Medical Aspect of NBC Defensive Operations*. NAVMED P5059; AFP 161-3. 31 August 1973. (Reprinted with basic including C1.)
- FM 8-285. *Treatment of Chemical Agent Casualties and Conventional Military Chemical Injuries*. AFM 160-12; NAVMED P-5041. 28 February 1990.
- FM 31-11. *Doctrine for Amphibious Operations*. NWP22(B)/AFM 2-53/LFM-01. 1 August 1967. (Reprinted with basic including C1-3.)
- FM 41-5. *Joint Manual for Civil Affairs*. OPNAV 09B2P1; AFM 110-7; NAVMC 2500. 18 November 1966.
- FM 100-27. *US Army/US Air Force Doctrine for Joint Airborne and Tactical Airlift Operations*. AFM 2-50. 31 January 1985. (Reprinted with basic including C1.)
- TB MED 507. *Occupational and Environmental Health Prevention, Treatment, and Control of Heat Injury*. NAVMED P-5052-5/AFP 160-1. 25 July 1980.

#### Army Publications

- AR 5-9. *Intraservice Support Installation Area Coordination*. 1 March 1984.
- AR 40-2. *Army Medical Treatment Facilities: General Administration*. 3 March 1978. (Reprinted with basic including C1-2.)

## INDEX

References are to paragraph numbers except where specified otherwise.

- absent without leave, 4-2*d*(2), B-2*a*(9), B-2*c*(17), B-3*b*
- AC. *See* active component.
- active component, B-9*c*(1)
- adaptive behavior, Table 1-2
- adjustment disorder, 6-3*t*(2)
- agitation, 4-6*c*(3)
- Alcohol and Drug Abuse Prevention and Control Program, 2-2*b*(1), 2-3*b*(1), 4-2*g*, B-3*b*
- alcohol misuse cases, 3-10*b*(2)
- alcohol support group, 4-2*g*
- ambulance exchange point, 3-3*b*(5)(*a*), 3-3*c*(3), 4-3*b*(1)
- amnesia, 4-6*c*(1)
- antianxiety drugs, 8-2*d*(5)(*e*)
- AO. *See* area of operations.
- area of operations, 2-2, 2-2*b*, 2-3, 3-6*a*
- area support medical battalion, 1-5*b*, 2-1, 2-3, 2-5*c* and *e*, 2-6*a*, 2-9*b*, 3-6*a*, 3-8*b*(4), 3-9
- area support medical company, 2-3*b*(4), 3-7, 4-5*a*(1)
- command post, 2-6*d*, 3-6*a*, 3-6*b*(1), 4-3*a*(2)
- headquarters and support company, 2-3, 3-6*b*
- mental health section, 2-1, 2-2*b*, 3-6*a*
- behavioral science specialist, 3-6*b*
- NCOIC, 3-6*b*
- psychiatrist, 3-6*b*(1)
- social work officer, 3-6*a*(2), 3-6*b*(1)
- armored cavalry regiments, 3-8*c*
- arms control, 1-4*d*
- Army combat stress control, 1-5*a*. (*See also* combat, stress control.)
- Army Emergency Relief, 4-2*a*(4)
- Army Operations, 1-4*a*, 1-4*c*, B-6*c*
- ASMC. *See* area support medical battalion, area support medical company.
- atropine, 6-3*q*
- attacks and raids, 1-4*d*
- AWOL. *See* absent without leave.
- AXP. *See* ambulance exchange point.
- BAS. *See* battalion aid station.
- base cluster, 4-5*a*(1)
- battalion aid station, 3-3*c*(3) and (4), 4-3*b*(1), 4-5*f*(2), 5-5*c*(2)
- battle fatigue, Table 1-2, 1-2*b*, 1-3*a*, 1-3*d*—*e*, 1-5*b*, 1-6, 1-8, 2-2—3, 2-5*b* and *d*, 2-6—12, 3-2*a*—*b*, 3-7, 4-1*c*, 4-6*b*(1), 6-3*t*(2)
- assessment of, B-2*b*
- cases, B-1*b*(1)
- casualty(ies), 1-6*b*, 3-2*b*, 3-3*e*(5), 3-4*b*(2), 3-6*b*(2), 3-8*b*(1)(*b*), 3-10*a*, 3-11, 3-11*b*, 4-1*b*(1), 4-3*a*—*b*, 4-5*d*, 4-6*b*(4), 6-3*t*, 8-1, 8-2, 8-3*c*—*d*, 8-4, 8-6
- categories, 3-3*d*, 4-5, 6-1*a*(1)
- Duty cases, 1-9*a*(3), 3-6*b*(2), 4-5*b*(2), 4-5*e*(2), 6-1*b*, 8-1*b*, 8-1*c*, 9-5*c*, B-2*a*(3), B-7*a*(1)
- Hold cases, 1-9*a*(3), 3-3*d*(3), 4-5*e*, 6-1*b*, 8-1*b*, B-2*a*(3), B-7*a*(2)
- Refer cases, 1-9*a*(3), 3-3*d*(4), 3-4*a*(4), 4-5*e*, 6-1*b*, 8-1*b*, 8-4*c*, 8-6*e*, B-2*a*(3), B-7*a*(2)
- Rest cases, 1-9*a*(3), 2-7, 3-3*d*(2), 3-6*b*(2), 4-5*b*(2), 4-5*e*—*g*, 6-1*b*, 8-1*b*, 8-1*c*, 8-6*d*, 9-4*a*(3), B-2*a*(3), B-7*a*(1)
- evacuation, 1-8*g*
- handling, 4-5*d*(4)
- hospitalization, 1-8*j*
- recognition of, B-2*a*
- treatment, 1-8, 4-1*c*
- examples of, Table 1-2
- hasty withdrawal, B-2*a*(8)
- positive coping, B-2*a*(6)
- prevention, 4-1*c*
- protective (positive) factors that reduce battle fatigue, B-2. (*See also* stress, positive factors.)
- risk (negative) factors. *See* stress, negative factors.
- tough realistic training, B-2*a*
- transport, 3-7*a*
- unit cohesion, B-2*a*
- unmanageable, 4-5*d*(5)
- warning signs, 1-3*d*
- behavioral science
- NCO, 2-2*b*, 3-1, 3-3*b*, 3-6*b*(2), C-3*c*
- specialist, 2-2*b*, 2-3*b*, 3-8*b*(1), C-3*c*
- BF. *See* battle fatigue.

- brigade, 1-4c
  - combat stress control
    - coordinator, 3-1, 3-2b
    - team, 2-2, 3-1, 3-3b—d, 3-3e(6)
  - support area, 3-3b, 3-3d, 3-8b(1), 3-8d(1), 4-3b(1) 4-5a(1), 4-5b(1)
  - surgeon, 3-3b
- BSA. *See* brigade, support area.
- C2. *See* command and control.
- casualty feeder report, 3-11a
- catastrophic events, 4-1b(3)
- ceremonies, 4-7a(3)
- chain of
  - command, D-1d
  - support, 1-1b
- CHAMPUS. *See* Civilian Health and Medical Programs of the Uniformed Services.
- chaplain, 1-5b, 1-6e, 2-6, 2-6b, 3-3b(1), 3-8b(2), 4-1c(1), 4-1d—e, 4-2d, 4-5f(2), 4-7b
- chronic diarrhea, 6-3a
- CHS. *See* combat health support.
- Civilian Health and Medical Programs of the Uniformed Services, 4-2a
- civil-military operations, 3-9a
- clearing station, 1-3d, 2-2b(5), 3-1, 3-3b(3) and (5), 3-3d(4), 3-3e, 3-4a(3), 3-6b, 3-7, 3-7b, 4-5e. (*See also* division clearing station.)
- cohesive unit, 1-6b
- combat
  - exhaustion, 1-6b—d
  - health support, 2-2a, 3-2a, 3-11b, 4-1b, 5-1c(3)
    - estimate(s), 4-3a(1), B-1
    - plan, 3-6a, 4-3a(1)
  - intensity, 3-2a, B-2b(1)
  - lifesaver, 3-3b(1)
  - medic, 4-1d(3)
  - neuropsychiatric triage, 1-9a(3), 3-1, 3-3d, 3-10b(1), 4-5d(5), 4-5g, 6-1, 8-1c
    - battle fatigue categories. *See* battle fatigue, casualty, categories.
    - considerations, 6-2
    - distinguishing battle fatigue categories by signs and symptoms, 6-1c
    - screening, 6-2a(2)
- combat
  - neuropsychiatric triage (*continued*)
    - physical screening, 6-2a(1)
      - considerations, 6-2a(3)
  - psychiatry principles, 1-7
  - service support, 1-4c, 1-6e, 4-5g(2)
  - stress control
    - consultation, 2-7, 3-1, 3-2b, 3-3b(2) and (5), 3-4a, Chapter 4, 8-1c
      - during combat, 4-5
      - priority, 4-5b(2)
      - target audiences, 4-1e
        - to medical personnel, 4-6d
        - to medical units, 4-5, 4-6d
        - to supported units, 4-1c and e, 4-2a and e, 4-4b, 4-5d
  - coordinator, 3-1, 3-3b—f, 3-6, 3-7b
  - elements
    - attachment of, 4-5a(2)
    - corps, B-6f
    - division, B-6e
  - estimates, B-1
    - for battle fatigue casualty work load, B-2
    - for misconduct combat stress behaviors, B-3
    - substance abuse, B-3
  - functional mission areas, 1-9
    - consultation, 1-9a(1). (*See also* combat, stress control, consultation.)
    - neuropsychiatric triage. *See* combat neuropsychiatric triage.
    - reconstitution support, 1-9a(2)
    - restoration, 1-9a(5)
    - stabilization, 1-9a(4)
  - functions, 2-5a
  - home station support, 4-4c
  - personnel, 4-1c(1)
  - plan, B-4
    - briefing the plan, B-10
  - planning consideration, B-6
    - in peacetime, B-9a
    - for operations other than war, B-7
  - point of contact, 4-4b
  - prevention, 1-4c—e, 4-3a
  - program, 1-5b
  - reconditioning, *See* reconditioning.

- combat
  - stress control (*continued*)
    - responsibility, 1-1b
    - restoration, *See* restoration.
    - support, 1-4c
      - team(s), 1-3d, 1-6e, 2-2, Figure 2-3, Figure 2-4, 2-5, 2-7—8, 2-10, 3-1, 3-2b, 3-3b, 3-4, 3-6a(4), 3-8, 3-10b, 4-5a, 9-4a(1), B-6d(2), B-6g
    - training, 4-1c(2)
  - service support, 1-6e, 4-5g(2)
  - support, 1-4c, 1-6e
    - hospital, 3-3e(3), 3-7b, 3-8b(4), 3-10b, 3-11b
  - uniform, 8-2d(4)(d)
  - zone (CZ), 2-5, 4-1e, 6-3t(2)
- combatting terrorism, 1-4d
- command and control, 2-6, 2-9, 3-8, 3-11b,
- command post (CP) exercise, 4-3a(2)
- command surgeon, 4-3a(1), 4-4a, 4-5a(2), 4-5b
- common table of allowances, Appendix A
- communications, 3-11b
- communications zone, 1-5b, 1-7c, 1-8k, 3-6a(4), 4-1e, 4-5a(1)
- conflict, 1-4d, 3-2, 3-3a, 3-8a, 3-8c—d, 3-10b(2)
- continental United States, p. vi, 1-6c, 1-7c, 1-8k, 4-7b, 6-3t(2)
- corps, 1-5b, 1-6e, 2-1—3, 2-5, 2-6a, 2-6c, 2-8—9, 3-1, 3-8b
  - area, 2-5, 2-7—8, 3-9
  - slice, 2-5
- counseling, 8-2i
- CP. *See* area support medical battalion, command post.
- criminal acts, Table 1-2
- CSH. *See* combat support hospital.
- CSS. *See* combat service support.
- debriefing, 8-2i
  - after-action, 1-3f, 3-4a(6), 3-6b(2), 4-2e(4), 4-3b(2), 4-5h
  - critical events, 1-5b, 3-3b(4), 4-5h, 4-5h(3), 5-1d, 5-4e
  - large group, 4-1c(2), 4-5h, 5-4e, 8-2i(1)
- dehydration, 6-3b
- delirium tremens, 6-3p(2)
- Delta Dental Plan, 4-2a(4)
- Department of Veterans Affairs, 9-6a
- depression, 4-6c(3)
- deputy for personnel and civilian affairs, 4-2d
- differential diagnostic problems, 6-3
  - air emboli, 6-3k
  - anticholinergic delirium, 6-3g
  - anticholinesterases, 6-3r
  - convulsive seizure disorders, 6-3o(3)
    - Guillain-Barre syndrome, 6-3o(1)
    - multiple sclerosis, 6-3o(2)
  - endemic personality disorders, 6-3t
  - focal brain ischemia, 6-3k
  - head trauma, 6-3g
    - epidural hematoma, 6-3g(1)
    - intracranial pressure, 6-3g(3)
    - subdural hematoma, 6-3g(2)
  - hypothermia, 6-3d
  - laser eye injuries, 6-3l
  - middle ear injuries/diseases, 6-3m
  - neurologic disorders, 6-3o
  - overuse syndromes, 6-3e
  - peripheral neuropathies, 6-3n
  - postconcussion, 6-3i
  - rhabdomyolysis, 6-3f
  - spinal cord trauma, 6-3h
  - substance misuse/abuse, 6-3p
    - heavy habitual use of alcohol, 6-3p(1)
    - hallucinogenic drugs, 6-3p(4)
    - inhalation of fumes, 6-3p(5)
    - intoxication or withdrawal, 6-3p(2)
    - overuse of stimulants, 6-3p(3)
- disciplinary action, 6-3t(2)
- DISCOM. *See* division support command.
- disease nonbattle injury, 1-2b, 3-6b(2), B-6j(2)
- disorientation, 4-6c(1)
- disruptive confusion, 4-6c(1)
- division, 3-1, 3-10a
  - clearing station, 1-6b, 3-1, 3-3b(3) and (5)
  - combat health support plan, 3-3a
  - fatigue center, 9-3h
  - G1, 3-3e(5)
  - medical operations center, 2-2a, 3-2a, 3-3a, 3-4a, 3-5, 4-1e
  - mental health section, 1-6d—e, 2-2b, Chapter 3, B-1b(1)
  - deployment, 3-1



- division
  - mental health section (*continued*)
    - employment, 3-3
    - senior behavioral science NCO, 2-2
    - senior behavioral science specialist, Figure 2-1—2, 2-2b(4)
  - psychiatrist, 1-6b—c, 2-2, 3-1—5, 3-8b
  - support area, 3-1, 3-2b, 3-3e—f, 3-5, 3-8b(2) and (4)
  - support command, 2-2, 3-2
  - surgeon, 3-2, 3-3c, 3-8b
- DMOC. *See* division medical operations center.
- DNBI. *See* disease nonbattle injury.
- drug misuse cases, 3-10b(2)
- DSM III-Rs, 6-3t(1)
- emergency treatment
  - NCO, C-3d
  - specialist, C-3d
- empathic management, 4-6c(3)
- enemy prisoner of war, 2-9, 4-2a(2), B-3b
- EPW. *See* enemy prisoner of war.
- esprit de corps, 1-3b
- euphoria, 4-6c(3)
- Exceptional Family Member Program, 4-2a(4)
- exhaustion center, 1-6b
- Family Advocacy Program, 4-2a(4)
- family issues, 4-2a(4)
- Field Medical Card (DD Form 1380), 2-8l, 6-2a(1)
- formal debriefing, 4-7b
- forward support battalion, 4-5e(2)
- forward support medical company, 2-2b(5), 3-1, 3-4a(1), 3-8b(1), 3-11b, 4-5a(1)
- four Rs, 7-4a(2)
- FSB. *See* forward support battalion.
- FSMC. *See* forward support medical company.
- G-5, 4-1e
- gas mania, 1-6a
- general hospital, 3-7b
- Geneva Convention, 4-2a(4), 4-5e(3), Appendix D
  - battle fatigue casualties, D-2b
  - criteria for patients, D-2b
  - protected status, D-1d(1), D-2c
  - care of civilian wounded or sick, D-8g
  - defense of medical units, D-8d
    - conditions not depriving medical units protection, D-8a
- Geneva Convention
  - defense of medical units (*continued*)
    - harmful acts, D-7a
    - loss of protection of medical establishments and units, D-7
  - enemy prisoners of war, D-2f
    - wounded and sick, D-4b
  - identification, D-5a(1), D-5c
    - card for medical personnel, D-5c
    - distinctive emblem, D-5a(1)
      - arm bands, D-5a(1), D-5c
    - prisoners of war, D-2f
  - Glasgow Coma Scale, Table 6-1
  - grief management, 4-2a(4)
  - Hague and Geneva Conventions, D-3a. (*See also* Geneva Convention.)
  - hasty withdrawal, B-2a(8), B-3b(8)
  - home front problems, 4-6c(5)
  - host nation, 3-9a
  - hostility, 4-6c(3)
  - humanitarian assistance and disaster relief, 1-4d
  - hyperthermia, 6-3c
  - IG. *See* Inspector General.
  - Individual Ready Reserve, 4-1e
  - Inspection General, 4-2d(1)
  - job reclassification, 6-3t(2)
  - joint operations, 1-4b
  - KO team, 1-6c—d
  - Korea, 1-6c
  - Law of War, D-3
  - LBE. *See* load bearing equipment.
  - leaders, 4-1d(3)
  - leadership, 4-1a
  - load bearing equipment, 8-2d(4)(d)
  - logistic package, 3-3c(4)
  - main support battalion, 2-1, 2-2a, 3-2
    - support operation, 3-3a
  - main support medical company, 2-2, 3-1, 3-8b, 4-5a(1)
    - commander, 3-3a
  - main supply routes, 4-5b(1)
  - malingering, 6-3t(2)
  - management guideline for—
    - agitated depression, 6-3s(1)
    - manic episode, 6-3s(4)

- management guideline for— (*continued*)  
 paranoid delusions, 6-3s(3)  
 predominantly auditory hallucinations, 6-3s(2)  
 schizophrenic-type thought disorder, 6-3s(2)  
 serious suicidal intent, 6-3s(1)  
 severe retarded depression, 6-3s(1)  
 sleep loss, 6-3s(1)  
 survival guilt, 6-3s(1)
- manic hyperactivity, 6-3p(3)
- mass casualty  
 plan, 3-9a  
 situations, 3-4a(5)
- MEDCEN. *See* medical center.
- MEDDAC. *See* medical department activity.
- media coverage, 1-4a(2)
- medical brigade, 3-3a, 3-6a(4), 3-9, 3-10a, 3-11, 4-5a(1)
- medical center, 9-6a
- medical company, combat stress control, 1-5b, Figure 2-3, 2-5, 3-3e(4), 3-8a, 3-10a, 3-11  
 assignment, 2-5c  
 attachment, 2-5e  
 basis of allocation, 2-5b  
 coordination and interface requirements, 3-11  
 employment in the theater, 2-5e  
 headquarters section, 2-6  
 armorer, 2-6j  
 chaplain, 2-6b  
 commander, 2-6a  
 commander's driver (behavioral science NCO), 2-6h  
 common table of allowances, Appendix A  
 cooks, 2-6n  
 first sergeant, 2-6d  
 light-wheeled vehicle mechanics, 2-6l  
 medical operations officer, 2-6c  
 motor sergeant, 2-6k  
 nuclear, biological, and chemical NCO, 2-6f  
 power generation equipment repairman, 2-6m  
 prescribed load list clerk, 2-6i  
 supply sergeant 2-6e  
 table of organization and equipment, Appendix A  
 unit clerk, 2-6g
- mission, 2-5
- medical company, combat stress control (*continued*)  
 organization, 2-5e  
 preventive section, 2-7  
 behavioral science  
 NCO, 2-7d  
 specialist, 2-7e  
 common table of allowances, Appendix A  
 psychiatrist, 2-7a  
 senior behavioral science specialist, 2-7c  
 social works officer, 2-7b  
 table of organization and equipment, 2-7a
- restoration section, 2-8  
 behavioral science  
 NCO, 2-8h  
 specialist, 2-8i  
 clinical psychologist, 2-8c  
 common table of allowances, Appendix A  
 occupational therapy  
 NCO, 2-8j  
 officer, 2-8a  
 specialist, 2-8k
- patient administration  
 NCO, 2-8l  
 specialist, 2-8m
- psychiatric  
 mental health nurse, 2-8b  
 NCO, 2-8f  
 specialist, 2-8g
- restoration team, 2-8
- senior  
 behavioral science NCO, 2-8d  
 psychiatric wardmaster, 2-8e  
 table of organization and equipment, Appendix A
- threat, 3-11b
- medical department activity, 4-2d, 9-6a
- medical detachment, combat stress control, 1-5b, Figure 2-4, 2-5, 3-3a, 3-3b(6), 3-8a, 3-9  
 assignment, 2-9b  
 base of allocation, 2-5b  
 command and control, 2-10a  
 headquarters, 2-10  
 commander, 2-10a  
 common table of allowances, Appendix A  
 table of organization and equipment, Appendix A

- medical detachment, combat stress control (*continued*)
  - NCOIC, 2-10*b*
  - mission, 2-9*a*
  - preventive section, 2-11
    - behavioral science
      - NCO, 2-11*d*
      - specialist, 2-11*e*
    - common table of allowances, Appendix A
    - psychiatrist, 2-11*a*
    - section sergeant, 2-11*c*
    - social works officer, 2-11*b*
    - table of organization and equipment, Appendix A
- medical group, 3-6*a*(4), 3-9, 3-11, 4-5*a*(1)
- medical intelligence, 3-9*a*
- medical treatment facility, 1-2*b*, 1-3*d*, 3-3*e*(4), 4-5*d*(5), 4-5*e*, 4-5*g*(3), 4-6*a—d*
- memorial ceremonies, 4-7*a*(3)
- mental fitness, 3-3, 3-3*f*(1), 3-6*b*(3)
- mental health
  - consultants, 4-1*d*(1)
  - CSC estimate, 3-2
  - CSC support, 3-3*b*
  - disciplines of, 4-1*d*(1)
    - clinical psychology, 4-1*d*(1)—(2)
    - occupational therapy, 4-1*d*(1)—(2)
    - psychiatric nursing, 4-1*d*(1)—(2)
    - psychiatry, 4-1*d*(1)—(2)
    - social work, 4-1*d*(1)—(2)
  - officer, 2-2, 3-2*b*
  - personnel, 1-5*b*
  - plan, 3-2*b*
  - sections, 2-1
    - ASMB. *See* area support medical battalion.
    - division. *See* division, mental health section.
- military police confinement facility teams, Appendix C
- mental health team
  - LA, C-2, Table C-1
  - LB, C-2, Table C-1
  - LC, C-2, Table C-1
  - LD, C-2, Table C-1
- misconduct
  - stress behavior, Table 1-2, 1-2*b*, 1-3*a*, 1-6*d*, 3-2*b*, 3-3*d—e*, 3-8*d*(1), 4-1*c*, 4-3*b*(1), 7-1*a*(1), B-3
  - missing in action, B-2*a*(8)
  - mobilization, 4-4*a*
  - moral dilemma, 4-6*d*(1)
  - MSB. *See* main support battalion.
  - MSMC. *See* main support medical company.
  - nation assistance, 1-4*d*
  - National Command Authority, 1-4*d*
  - NBC. *See* nuclear, biological, and chemical.
  - neurological hospitals, 1-6*a*
  - neuropsychiatric
    - cases, 3-3*b*(3), 3-3*d—e*, 3-7
    - casualties, 3-3*b*(2)
    - diagnosis, 1-4*e*
    - disorders, 1-4*e*, 1-6*a*, 4-6*c*, 8-4*e*
    - prevention and screening program, 1-4*e*
    - triage. *See* combat, neuropsychiatric triage.
  - noncombatant evacuation operations, 1-4*d*
  - noncommissioned officer, 1-1*b*
  - nonjudicial punishment, 1-3*c*
  - nonreturn to duty, 3-9*a*
  - not yet diagnosed, nervous, 1-6*a*
  - nuclear, biological and chemical, 1-4*a*(1), 3-5, 3-9*b*
    - agent, 7-1*a*(2)
  - occupational therapy, 2-8, 3-8*b*(2)
  - ODS. *See* Operation Desert Shield/Storm.
  - OM Team, 1-6*d*, 2-5
  - OPCON. *See* operational control.
  - Operation Desert Shield, 1-6*e*
  - Operation Desert Storm, 1-6*e*
  - operational control, 3-8*b*(5), 3-9*b*, 3-11*b*
  - operation(s)
    - orders 2-2*a*, 3-9*a*, 3-11*a*
    - other than war, 1-4*a*(2), 1-4*d*, 4-1*b*(2)
    - plans, 2-2*a*, 3-9*a*, 3-11*a*
  - OPLANs. *See* operations plans.
  - OPORDs. *See* operations orders.
  - organic mental disorders, 4-6*c*(1)
  - overevacuation, 3-3*b*(5)(*b*)
  - overstressed soldiers, 4-2*a*(4)
  - panic attack, 6-3*p*(3)
  - paranoid psychosis, 6-3*p*(3)
  - patient-holding, 3-9*b*
    - squad, 3-3*d*, 3-3*e*(2), 3-6*b*(2)
  - PCP. *See* Phencyclidine hydrochloride.
  - peace enforcement, 1-4*d*

- peacekeeping operations, 1-4*d*
- personnel reliability screening, 4-2*f*
- Phencyclidine hydrochloride, 6-3*p*(4)
- physical conditions, 6-2*b*
- physician assistants, 3-3*d*
- physostigmine 6-3*q*(2)
- PIES. *See* principles for treating battle fatigue, proximity, immediacy, expectancy, simplicity.
- POCs. *See* point(s) of contact.
- point(s) of contact, 4-4*b*, 4-5*d*(3)
- positive combat stress behaviors, Table 1-2
- positive coping, B-2*a*(6)
- post-traumatic stress disorder, Table 1-2, 1-2*b*, 1-5*b*, 4-1*c*
  - common signs/warning signs, 1-3*f*
  - symptoms, 1-3*f*
- preexisting personality disorders, 6-3*t*
- principles for treating battle fatigue, 1-7*b*(1)—(4), 7-4*a*
  - proximity, immediacy, expectancy, simplicity, 1-7*b*, 7-4*a*(1)
- professional officer filler system, 4-1*e*
- PROFIS. *See* professional officer filler system.
- protective mask, 8-2*d*(4)(*d*)
- protective (positive) factors against substance abuse and misconduct stress behaviors, B-3*a*. (*See also* stress, positive factors.)
- psychiatric disorders
  - symptoms, 6-3*s*
  - nurse, 3-8*b*(2), 3-10*b*(4), 4-1*d*(1)
  - reaction (potential), 4-6*c*(3)
- psychiatrist, 1-6*a*, Figure 2-1, 2-2*b*(1), Figure 2-2, 2-3*b*(1), 3-7, 3-10*b*(4), 4-5*e*, 6-3*t*(1)
- psychologist, 6-3*t*(1)
  - clinical, Figure 2-1, 2-2*b*(2), C-3*b*
- PTSD. *See* post-traumatic stress disorder.
- pyridostigmine, 6-3*r*
- questionnaires, 2-2*b*(6), 4-2*c*(3)—(4)
- racial and ethnic tension, B-3*b*(11)
- rage attack, 6-3*p*(3)
- readiness, 4-1*a*
  - detractors, 4-1*c*(1)
- reconditioning, 1-8*k*, 1-9*a*(6), 3-10*b*, 4-3*a*, 8-6*e*, Chapter 9
  - reconditioning (*continued*)
    - evacuation of cases, 9-4*c*
    - facility, 3-10*c*
    - first-line cases
      - disposition, 9-4
      - evacuation policy, 9-4*b*
    - first-line reconditioning center, 9-3
      - area for establishment, 9-3*b*
    - medical records, 9-3*d*
    - program for treating battle fatigue casualties, 4-1*e*
      - combat fitness reconditioning center, 3-10*b*(2), 3-11*e*, 9-3*a*
        - located with hospital, 9-3*c*
        - located in the corps, 9-3*a*
      - temporary reassignments, 9-2*n*
      - work assignments, 9-2*m*
      - work projects, 9-2*l*
    - referral for administrative action, 8-6*g*
    - referral to hospitals, 8-6*f*
    - second-line reconditioning in the COMMZ, 9-5
      - Option 1, Field Hospital, 9-5*a*
      - Option 2, CSC units, 9-5*b*
    - small reconditioning center, 9-3*f*
    - third-line, 9-1*b*(3), 9-6*a*
    - treatment, 4-5*g*(3)
    - treatment program, 9-1
      - group sharing, 9-2*g*
      - group training
        - common soldier task, 9-2*j*
        - drug and alcohol counseling, 9-2*k*
        - life skills, 9-2*i*
        - relaxation techniques, 9-2*h*
        - survival skill drills, 9-2*j*
    - individual counseling and therapy, 9-2*f*
    - methods, 9-2
    - military unit structure, 9-2*b*
    - overview, 9-1*a*
    - physical activities, 9-2*e*
    - physical replenishment, 9-2*c*
    - priority for, 9-1*b*
    - unit formation, 9-2*d*
    - validation, 9-2*g*
  - reconstitution
    - combat stress control, Chapter 5

- reconstitution
  - combat stress control (*continued*)
    - involvement, 5-1*d*
    - Phase I: Preparation and Deployment, 5-2
      - coordination, 5-2*a*
      - familiarity with the supported unit, 5-2*b*
      - unfamiliarity with the supported unit, 5-2*c*
    - Phase II: Reduction of Human Physical/Physiologic and Cognitive Stressors, 5-3
      - continuing physiologic replenishment, 5-3*c*
      - monitoring, 5-3*a*
      - physical/physiologic replenishment, 5-3*b*
    - Phase III: After-Action Debriefings, 5-4, 5-5*b—c*
      - critical events debriefing, 5-1*d*(1), 5-4*e*(2)—(4), 5-4*f*
      - facilitator for after-action debriefing, 5-4*e*
      - large group debriefing, 5-4*c*
    - Phase IV: Rebuilding Unit Cohesion, 5-5
      - assisting units to rebuild cohesion, 5-5*a*
      - individual assistance with battle fatigue, 5-5*c*
      - integrate new replacements, 5-5*b*
    - Phase V: Performing Final Combat Stress Control Requirements, 5-6
      - building unit confidence, 5-6*c*
      - closing out reconstitution support, 5-6*d*
      - unit cohesion, 5-6*b*
    - requirements, 5-1*d*(2), Table 5-1
  - process, 5-1*a*
  - regeneration
    - characteristic of, 5-1*c*
    - key combat stress control issues, 5-1*c*(1)
  - reorganization, 5-1*a*
    - deliberate, 3-8*b*(1), 5-1*a*(1)(*b*)
    - hasty, 3-8*b*(1)
    - immediate, 5-1*a*(1)(*a*)
  - site, 5-1*c*(2)
  - support, 3-8*b*(1), 3-10*b*(1), 5-1, 8-1*c*
  - reduction in force, 4-7*e*
  - Reserve Component, 4-7*e*, B-9*c*(2)
  - rest center, 1-6*b*
  - restoration, 3-2*a*, 3-8*b*(1)(*b*), 8-1*a*
    - categories of, 8-1*d*
      - first-line, 8-1*a*, 8-3
        - armored cavalry regiment, 8-3*b*
        - Communications Zone, 8-3*c*
        - corps, 8-3*c*
        - separate brigade, 8-3*b*
      - second-line, 8-1*a*, 8-4
        - fatigue center, 8-4*b*
        - location, 8-4*a*
      - third-line, 8-1*a*, 8-5
    - considerations for hospitals, 8-5*b*
    - duties and work details, 8-2*g*
    - Duty cases, 8-1*b*
    - facility, 3-3*e*(4)
    - Hold cases, 8-1*b*
    - medical company support, 8-3*d*
    - military identity, 8-2*e*
    - priority, 8-1*c*
    - program, 2-7, 4-1*e*
    - reassurance, 8-2*b*
    - recovery time, 8-6*d*
    - Refer cases, 8-1*b*
    - referral, 8-6
    - relaxing activities, 8-2*h*
    - replenishment
      - A-Rations, 8-2*d*(3)(*a*)
      - of physiologic status, 8-2*d*
      - intravenous fluids, 8-2*d*(2)
      - restore hygiene, 8-2*d*(4)
      - structured activities, 8-2*f*
    - Rest cases, 8-1*b*
    - restoring confidence, 6-2*a*(5)
    - restraints, 3-7*a*
    - return to duty, 8-6
      - screening and treatment, 8-1*b*
      - site, 8-2*a*(5)
      - structured military environment, 8-2*c*
      - tactics, techniques, and procedures, 8-2
      - team, 2-10, 3-8*b*(1)—(2), (5), 3-8*d*(2), 3-10*b*, 9-3*b*
      - techniques, 8-4*d*
      - treatment, 3-3*d*(2), 4-5*g*(3)
    - return to duty, 1-2*b*, 1-4*e*, 1-5*b*, 1-8*b*, 2-2*b*(5), 3-3*b*(5)(*e*), 3-9*a*, 4-1*b—c*, 4-3*a*, 4-5*b*(2)
    - risk factors (stressors), 4-1*a*

- risk (negative) factors which increase substance abuse and misconduct stress, B-3b
- RTD. *See* return to duty.
- rules of engagement, 4-7b(1)
- S1/G1, 4-1e, 5-1c(3), B-1a
- S2/G2, 4-1e, B-1a
- S3/G3, 2-2a, 4-1e, B-1a
- S4/G4, 4-1e, 5-1c(3), B-1a
- security assistance, 1-4d
- sedatives and tranquilizers, 1-8f
- separate brigade, 2-4, 3-8c(2)
- sergeant's business, B-2a(5)
- shell shock, 1-6a, D-2f(1)(a)
- show of force, 1-4d
- signal operating instructions, 3-9b
- sleep, restorative, 8-2d(5)
- sleeping medication, 8-2d(5)(d)
- small group therapy, 4-6d(5)
- social withdrawal, 4-7b(2)
- social work officer, Figure 2-1, 2-2b(3), Figure 2-2, 2-3b(2), C-3a
- stabilization, 3-10b(1), Chapter 7
  - administering medications, 7-3a
  - effects of antipsychotic drugs, 7-3d
  - evacuation and treatment modalities, 7-4b
  - facility, 7-5a
  - full, 7-1b, 7-4
  - initial
    - emergency, 7-1a
    - use of medications, 7-3a
    - physical restraints, 7-2a
  - medications, observing for reactions, 7-3b
  - methods of restraining, 7-2c
  - mixed neuropsychiatric and medical/surgical ward, 7-5c
  - neuropsychiatric ward, 7-5b
    - staff, 7-5d
  - neuropsychiatric/battle fatigue casualties, 9-3e
  - rapid sedation, 7-3c
  - subduing and restraining, 7-2b
- staff chaplains, 4-1e
- stress, 1-1a, 8-2b(4)
  - and stressors, 1-5b
  - assessment, 5-1c(1)
  - casualties, 1-2b, 4-1b
  - casualty estimates, 4-3a
- stress (*continued*)
  - combat stress behaviors, 1-3a, Table 1-2
  - combat stress reaction, 1-3d
  - control of stress, 1-1b
  - control principles and techniques, 3-6b(2)
  - controlling stressors, 4-3a
  - dysfunctional stress behavior, Table 1-2
  - examples of misconduct stress behaviors, 1-3c, Table 1-2
  - examples of positive combat stress behaviors, 1-3b, Table 1-2
  - excessive stress, warning signs, 4-2d(2)
  - fight or flight response, 1-3b
  - harmful combat stress behaviors, B-3b in the unit, 4-2d
  - indices of excessive stress in units, 4-2d(2)
  - induced disability, 1-4e
  - intervention techniques, 3-6b(2)
  - mental stressors, 1-2c, Table 1-1
  - misconduct stress behavior, 1-3c, 1-4d
  - negative stress factors, B-1c(2)—(5), (7), B-2c, B-3b
  - on the enemy, 1-2a
  - on the home front, 4-2d
  - physical stressors, 1-2c, Table 1-1
  - positive combat stress behavior, 1-2d
  - positive stress, 1-2d
    - factors, B-1c(5), B-2a(1), B-2b(1), (3)—(4), B-3a(1)
  - prevention, 4-1b
  - recognition and control, 4-1d(3)
  - related casualties, 3-1, 3-3d, 4-1a
  - related illness, 6-3a
  - threat, 1-2
  - tolerance, 1-4b
  - uncontrolled combat stress, 1-1a
- stressors, 4-2d(1), 4-6d(1)
  - combat, 1-2a
  - home-front, 3-2a
  - reducing, 4-6d(2)
- substance abuse, 1-4e, 1-6d, B-3
- suicide attempts, 4-2d(2), 4-6c(2)
- Surgeon General of the Army, 1-6a
- survey, 2-2b(6)
  - questionnaires, 4-2c

- table of organization and equipment, p. vi, 2-5
- tactical operations center, 4-5*b*(1), 4-5*e*(3)
- tactical standing operating procedures, 3-2*a*
- task-organized CSC element, 2-8, 3-10*b*(3)
- technical channels, 3-9
- theater of operations, p. vi, 1-6*e*, 1-8, 4-2*a*, 4-7*b*
- threat, 4-5*b*(1), B-2*c*(7)
- time management, 4-2*a*(4)
- TO. *See* theater of operations.
- TOC. *See* tactical operations center.
- training and rehabilitation center, 1-6*b*
- training, tough realistic, B-2*a*(2)
- transition workshop, 4-2*e*
- traumatic incident, 4-3*b*(2)
- triage, 3-3*d*
- Tunisia Campaign, 1-6*b*
- UCMJ. *See* Uniform Code of Military Justice.
- Uniform Code of Military Justice, 1-3*c*
- unit
  - cohesion, 1-1*a*, 1-6*e*, 4-1*a*, 4-2*a*(4), 4-2*c*, B-2*a*(1)
  - ministry team, 4-1*e*
  - morale, 4-1*b*(2)
  - sleep plan, 4-2*b*, 4-6*d*(2)
  - surgeon, 4-2*d*
  - survey, 4-2*b*
  - ventilation, 8-2*i*
  - veterinary corps, D-8*f*
  - Vietnam, 1-6*d*
  - violent behavior, 7-1*a*(1)
  - war, 3-10*a*
    - neurosis, 1-6*a*
  - World War I, 1-6*a*
  - World War II, 1-6*b*
    - principles learned, 1-6*b*
  - wounded in action, 1-2*b*
  - WWI. *See* World War I.
  - WWII. *See* World War II.

**FM 8-51**  
**29 SEPTEMBER 1994**

By Order of the Secretary of the Army:

Official:

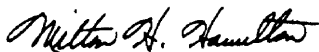
  
MILTON H. HAMILTON  
Administrative Assistant to the  
Secretary of the Army  
07166

GORDON R. SULLIVAN  
General, United States Army  
Chief of Staff

**DISTRIBUTION:**

*Active Army, USAR, and ARNG:* To be distributed in accordance with DA Form 12-1IE, requirements for FM 8-51, Combat Stress Control in a Theater of Operations, Tactics, Techniques, and Procedures (Qty rqr block no. 4901).



**PIN: 073030-001**